

**ANTES DE COMENZAR, RECOPILE TODO EL MATERIAL DE APOYO PARA EL MONTAJE:** Instrucciones de montaje / ilustraciones paso a paso / planos y plantillas impresos a escala.

**PREPARACIÓN DEL MATERIAL:** Para poder identificar correctamente las piezas precortadas, antes de extraerlas de las planchas de madera, marque en ellas la misma numeración que aparece en la hoja "IP" (identificación de piezas), incluida en las instrucciones.

**INICIO DEL MONTAJE:** Con la ayuda de un cúter y procurando no colocar los dedos en la línea de corte, desprenda las piezas de las planchas eliminando los pequeños nervios que las sujetan. Seguidamente lije con suavidad las piezas con papel de lija de grano fino, para eliminar el repelo de las mismas. El orden numérico del paso a paso indica el orden de elaboración y colocación de las piezas. Es importante comprobar el ajuste de las piezas antes de pegarlas definitivamente.

**LISTONES Y VARILLAS:** Los modelos incorporan varios tipos de listones y varillas para elaborar las diferentes piezas. La lista de piezas proporciona información sobre el tipo de material y medidas. En algunos casos es conveniente ajustar las medidas sobre el propio modelo, conforme avanzamos en el montaje. De esta manera se consigue un mejor ajuste.

**PEGAMENTOS RECOMENDADOS:** Cola blanca o de carpintero. Para las uniones de piezas de madera y de todas aquellas piezas que no ofrezcan resistencia.

Pegamento rápido. Para piezas que sean difíciles de sostener y que necesiten un secado casi instantáneo.

Cola de contacto o de zapatero. Para todas aquellas piezas que se forren con chapas finas de madera o metal. En todos los casos, lea siempre las instrucciones de uso del fabricante.

**SERVICIO DE ATENCIÓN AL CLIENTE:** Para cualquier duda o información sobre el montaje de nuestros productos, puede contactar con nuestro Servicio Técnico en la dirección:

[www.occre.com](http://www.occre.com). Le atenderemos con mucho gusto.

**BEFORE STARTING, MAKE SURE YOU HAVE ALL THE SUPPORT MATERIAL FOR ASSEMBLING THE MODEL:**

Assembly Instructions / Step by step pictures / Plans and templates printed to scale.

**PREPARING THE MATERIAL:** In order to correctly identify the precut parts, before removing them from the wooden sheets, mark on them the same numbers that appear on the "IP"

(Part Identification) Sheet included with the instructions.

**STARTING THE ASSEMBLY:** Using a cutter, and making sure you do not put your fingers along the cutting line, remove the parts from the wooden sheets, eliminating the small sprues that hold them in place. In continuation smoothly sand down the parts, using fine grain sandpaper, to eliminate the pickup of the parts. The numerical order indicates the order in which the different parts must be made up and fitted.

**STRIPS AND RODS:** These models incorporate a variety of different types of strips and rods with which to make up the different parts of the kit. The list of parts proportions information on the type of material and measurements. In some cases it is advisable to adjust the measurements on the basis of the model itself, as assembly progresses. In this way you will achieve a better fit.

**RECOMMENDED GLUES:** White, or carpenter's glue: For joining pieces of wood together. Mainly used for gluing together the skeleton. Quick-drying glue. For parts that are difficult to hold in their final position and which need to set instantly. Recommended for fitting small parts. Contact or cobbler's glue. For gluing into place the parts that are covered with fine wood veneer to set instantly. In all cases, always follow the manufacturer's recommendations.

**CUSTOMER ATTENTION SERVICE:** In the case of whatsoever doubt or further information that you may require regarding the assembly of our products, please contact our Technical Service online at the address: [www.occre.com](http://www.occre.com). We will be delighted to attend to you.

**AVANT DE COMMENCER, VÉRIFIEZ TOUT LE MATÉRIEL DE SOUTIEN POUR LE MONTAGE:**

**PRÉPARATION DU MATÉRIEL:** Pour pouvoir identifier correctement les pièces prédécoupées, avant de les extraire des planches de bois, inscrivez sur elles la même numérotation qui apparaît sur la page « IP » (identification des pièces) comprise dans les instructions.

**DÉBUT DU MONTAGE:** À l'aide d'un cutter, et en essayant de ne pas poser les doigts sur la ligne de découpe, séparez les pièces des planches en éliminant les petits nerfs qui les retiennent. Puis poncez doucement les pièces à l'aide d'un papier de verre à grain fin, pour éliminer le contrefil. L'ordre numérique des étapes photographiques et des plans indique l'ordre d'élaboration et d'installation des pièces.

**LISTEAUX ET BAGUETTES:** Les modèles intègrent plusieurs types de listeaux et de baguettes destinés à confectionner les différentes pièces. La liste des pièces indique le type de matériau et les dimensions des pièces. Il est parfois recommandé d'ajuster les mesures sur le modèle lui-même, au fur et à mesure que nous avançons dans le montage. De cette manière, on obtient un meilleur réglage.

**COLLES RECOMMANDÉES:** Colle blanche ou de menuisier: Pour les unions de pièces en bois et de toutes les pièces qui n'offrent pas de résistance. Colle à séchage rapide: Pour les pièces qui sont difficiles à maintenir dans leur position et qui requièrent un séchage pratiquement instantané. Colle de contact ou de cordonnier: Pour toutes les pièces qui sont recouvertes de fines plaques de bois ou de métal. Dans tous les cas, lisez toujours les instructions d'utilisation du fabricant.

**SERVICE CLIENT:** Pour toute question ou information concernant le montage de nos produits, vous pouvez contacter notre Service Technique à l'adresse suivante: [www.occre.com](http://www.occre.com).

Nous répondrons avec plaisir à vos questions.

**PRIMA D'INIZIARE, RIUNIRE TUTTO IL MATERIALE D'APPOGGIO PER IL MONTAGGIO:** Istruzioni di montaggio, immagini passo per passo, planimetrie e modelli stampati in scala.

**PREPARAZIONE DEL MATERIALE:** Per poter identificare in maniera corretta i pezzi che sono stati ritagliati, prima di estrarli dai blister di legno occorre segnarli con la stessa numerazione che è indicata nella pagina "IP" (Identificazione pezzi) che si trova nelle istruzioni.

**INIZIO DEL MONTAGGIO:** Con l'aiuto di un cutter, ed evitando di collocare le dita lungo la linea di taglio, separare i pezzi dai blister eliminando i piccoli nervi che li mantengono attaccati.

In seguito, scartavetrare con delicatezza i pezzi, utilizzando una carta vetrata a grana fine, onde eliminare le sbavature degli stess. L'ordine numerico del passo per passo indica l'ordine d'elaborazione e di collocazione dei pezzi. È importante verificare che questi combacino bene, prima d'incollarli definitivamente.

**ASTE E BACCHETTE:** I modelli sono dotati di vari tipi di aste e bacchette per formare i diversi pezzi. L'elenco dei pezzi offre informazioni sul tipo di materiale e sulle misure. In alcuni casi è conveniente modificarne le misure quando sono sul modello, man mano che si avanza nel montaggio. In questo modo si potrà ottenere che combacino meglio.

**COLLE RACCOMANDATE:** Colla bianca o da falegname: Per unire tra loro i pezzi in legno e tutti quei pezzi che non presentino resistenza. Colla rapida: Per i pezzi difficili da sostenere e per i quali sia necessaria un'asciugatura quasi istantanea. Colla a contatto o da calzolaio: Per tutti quei pezzi che vengono rivestiti con fine lastre di legno o di metallo. In ogni caso, leggere sempre le istruzioni d'uso del produttore.

**SERVIZIO ASSISTENZA CLIENTE:** Per qualsiasi dubbio o informazione sul montaggio dei nostri prodotti, contattare il nostro Servizio Tecnico al seguente indirizzo: [www.occre.com](http://www.occre.com).

Seremo lieti di potervi aiutare.

**BEVOR SIE MIT DEM ZUSAMMENBAU BEGINNEN, LEGEN SIE SICH BITTE ALLE HILFSMATERIALIEN FÜR DIE MONTAGE BEREIT:**

Bastelanleitung / Maßstabgerechte Skizzen und Schablonen / Skizzen und Vorlagen.

**VORBEREITUNG DER MATERIALIEN:** Damit die einzelnen Bauteile korrekt zugeordnet werden können, empfehlen wir, auf den Holzplättchen vor dem Herausnehmen mit einem Bleistift die Nummer auf dem Blatt IP (Identifikation Teile) zu markieren.

**BEGINN DES ZUSAMMENBAUS:** Die Teile mit einem Schneidwerkzeug (Cutter) herauslösen und die kleinen Befestigungsenden entfernen. Dabei darauf achten, die Finger nicht zu verletzen. Danach die Teile vorsichtig mit feinem Schmirgelpapier säubern, um ausgefranste Ränder zu entfernen. Die Nummernfolge der Schritte auf Fotos und Skizzen gibt an, in welcher Reihenfolge die Teile zusammengebaut werden.

**LEISTEN UND STÄBE:** Die Modelle enthalten mehrere Arten von Leisten und Stäben, aus denen die einzelnen Teile des Bausatzes geformt werden. In einigen Fällen kann es angebracht sein, die Maße im Zuge des Zusammenbaus entsprechend dem Modell anzupassen. Auf diese Weise wird eine bessere Passform erricht.

**EMPFOHLENE KLEBSTOFFE:** Weißleim (Tischlerleim): Zum Kleben von Strukturteilen und allen nachgiebigen Teilen. Sekundenkleber: Für schwer zu haltende Teile, die schnell verklebt werden müssen. Kontaktkleber (Schusterleim): Für alle Teile, die mit dünnen Holz- oder Metallstücken zum Beplanken oder Verkleiden beklebt werden. Bitte beachten Sie stets die Hinweise des Herstellers.

**UNSER KUNDENDIENST:** Bei Fragen zum Aufbau unserer Modelle steht Ihnen unser Kundendienst zur Verfügung. Sie erreichen uns online unter: [www.occre.com](http://www.occre.com).

Wir stehen Ihnen gern mit Rat und Tipps zur Verfügung.

## INSTRUCCIONES DE MONTAJE ESSEX

**A-** Siguiendo el orden alfanumérico inserte y pegue las piezas indicadas en las figuras. Antes de encolar las cuadernas, verifique que encajan correctamente en su posición haciendo “tope” en los encajes correspondientes de la falsa quilla. Es importante que las cuadernas queden completamente perpendiculares a la falsa quilla para que posteriormente encajen bien las cubiertas. Para esta operación utilice como adhesivo cola blanca, (cola de carpintero).

Trace una línea longitudinal que divida la cubierta **A19** en dos mitades simétricas. Comience a forrar ajustando la primera tira a la línea de lápiz. Utilice como adhesivo cola de contacto, (cola de zapatero). Con el mango de madera de una herramienta, frote fuertemente las chapas contra la cubierta para que se adhieran con firmeza. Coloque la cubierta bocabajo y corte los sobrantes de las chapas. Después, trace unas líneas para simular la tablazón. Lije la cubierta y aplíquela laca tapa-poros incolora.

**B-** Pegue la cubierta **A19** forrada sobre la estructura del barco. Es importante que la cubierta se apoye correctamente sobre las cuadernas. Lije la parte superior de las cuadernas de proa y de popa y los perfiles de las cubiertas con un taco lijador. Con esta operación se facilitará el apoyo de las amuradas. Para este proceso utilice un pegamento rápido. Introduzca las piezas **B1** en agua para que recuperen flexibilidad. Utilice algún objeto cilíndrico para curvarlas poco a poco sin romperlas. Adapte y pegue las piezas **B1** con cola blanca y puntas. El clavador es una herramienta OcCre (opcional), que se utiliza para sujetar y clavar al mismo tiempo las puntas.

**C-D-** Coloque el casco boca abajo y comience a lijar empezando desde proa y avanzando hacia popa. Debe desbastar los tacos de refuerzo y las aristas de las cuadernas pero sin deformar su forma original. El lijado del casco ha de quedar simétrico, es decir, que el lateral derecho ha de quedar igual que el izquierdo. Para la zona media del casco, utilice un taco lijador con mayor superficie. El lijado debe ser progresivo y suave. Compruebe con un listón, que el lijado es correcto. Para ello, debe deslizar el listón, sobre las cuadernas, para ver como se ajusta a su forma. Tome los listones **C1** y sumérgalos en agua unos veinte minutos. Con esta operación, recuperarán flexibilidad. Comience el forrado del casco ajustando el primer listón a la parte inferior de la amurada. Observe las imágenes siguientes antes de proceder. Debe pegar los listones a las cuadernas y entre sí con cola blanca y fijarlos con puntas.

Pegue otro listón a continuación del primero, que llegue hasta popa. Continúe el mismo proceso para forrar el casco entero. Deberá cortar a medida y ajustar las piezas para que encajen en los huecos.

Si en algún punto le ha quedado alguna traca suelta, puede aplicar pegamento de secado rápido. Si le ha quedado alguna traca más hundida, pegue otra encima y después, desbástela. Pegue los refuerzos **D1, D2, D3, D4, D5, D6, D7, D8** y **D9**. Lime las cabezas de las puntas hasta que queden enrasadas con el forro. Después, lije todo el casco. Debe quedar suave y sin desniveles.

**E-** Utilizando como adhesivo, cola de contacto, (cola de zapatero), coloque el forro **E1**. Este segundo forro, se coloca de la misma manera que el primero. Debe cerrar los huecos con cuñas y frotar las chapas con firmeza para que se adhieran al casco. A medida que avance con el forro, abra los orificios que las amuradas llevan de origen. Procure que las tiras de forro queden lo más juntas posible para conseguir un buen acabado. Continúe el forrado del casco hasta completarlo. Después, lije todo el casco con lija de grano fino para dejar su superficie uniforme.

**F-** Forre el interior de las amuradas con el forro **F1**. Elabore y pegue las piezas que le indican las imágenes. Algunas de las piezas deberá teñirlas con tinte al agua de color nogal. Después aplique una capa de laca tapa-poros incolora a todo el casco y a las piezas añadidas.

**G-H-I-** Elabore y pegue las piezas que le indican las imágenes. Utilice la plantilla **PL-01** como guía. Elabore las piezas de decoración del espejo y pinte de color azul el fondo donde irán colocadas las ventanas. Si desea pintar el barco, observe previamente las imágenes siguientes y no tiña aquellas piezas que vaya a pintar. Deberá lijar aquellas zonas del casco que barnizó, para que la pintura agarre con firmeza. Utilice cinta de carroceros para aislar las zonas que desee pintar. Para el proceso de pintado utilice pinturas acrílicas al agua; blanco, negro, marrón, rojo, etc. Es aconsejable, lijar previamente las piezas que vaya a pintar. Construya las casetas y barnícelas antes de añadirles las piezas de metal.

**J-K-** Para elaborar los cadenotes **J12**, anude un hilo alrededor de una vigota, aplique pegamento de secado rápido y corte uno de los sobrantes de hilo. Después, inserte el extremo del hilo a través de las mesas de guarnición. Fije el hilo a una punta clavada en el casco mediante un nudo simple. Para construir las barcas, inserte cada cuaderna en la posición que le indican las imágenes, después lije los conjuntos obtenidos. Utilice la hoja **IP** para identificar las cuadernas de las barcas. Tiña los listones con tinte a agua color sapelli y forre con ellos los cascos de las barcas. La primera tira de forro debe colocarla ajustada a las marcas de corte que las cuadernas tienen en su parte inferior. Corte las cuadernas por la marca de corte y sepárelas de la base. Tiña las piezas de color sapelli o pino para diferenciar las piezas. Añada las piezas necesarias para completar las barcas.

## ARBOLADURA

Para elaborar los mástiles, el primer paso a seguir será cortar las varillas según las medidas que indica la lista de piezas, o bien tomarlas directamente de los planos que están impresos a escala 1/1.

Todos los mástiles y vergas tienen cierta conicidad que se deberá realizar.

Para realizar la conicidad a los mástiles, lije las varillas, (con un lijador), aumentando el desgaste de ésta a medida que se acerca al extremo donde se quiere disminuir el diámetro. Haga rodar la varilla para que el desgaste sea igual por todo el contorno hasta conseguir llegar al diámetro que indica el plano.

Para elaborar la conicidad de las vergas, realice las mismas operaciones, pero esta vez a ambos extremos de la varilla.

Deberá teñir o pintar las varillas en función del modelo que esté construyendo.

Para realizar correctamente los mástiles de este modelo se deberá tener en cuenta:

Los planos, las fotos de detalle de los mástiles, las medidas y descripción de materiales de la lista de piezas y las hojas “IP” de identificación de piezas.

Los mástiles se deberán barnizar y algunas de las piezas que los componen se deberán pintar. Véanse las fotos generales de detalle de los mástiles.

Una vez montados y barnizados, deberán colocarles los aparejos, (estrobos, cuadernales, cáncamos, motones, etc.), y fijarlos al barco.

Los mástiles se deben introducir hasta hacer tope en los encajes de la falsa quilla.

## JARCIA

Para elaborar la jarcia de este barco, siga el orden alfabético de las figuras impresas de los planos, que indican el orden de colocación: de hilos, vigotas, motones, velas, etc, destacados en color rojo. La lista de piezas le orientará sobre el tipo de materiales y medidas a utilizar.

Para simular el envejecido de las velas, se les puede dar un baño con infusión de té, sin hacerlas hervir, y dejarlas secar bien arrugadas. Se colocaran sin planchar para que tengan cuerpo.

## ASSEMBLY INSTRUCTIONS ESSEX

**A:** Following the alphanumeric order, fit and glue the parts indicated in the figures. Before gluing the frames into place make sure that they have been correctly and “snugly” fitted into position on the corresponding slots in the false keel. It is important to make sure that the frames are completely perpendicular to the false keel to ensure that the decks fit correctly. Use white (or carpenter’s) glue as the adhesive for this operation. Using a pencil, draw a lengthways line to divide the deck (**A19**) into two symmetrical halves. Start to line the deck with the planking, aligning the first strip along the pencil line. Use contact (or cobbler’s) adhesive. With the wooden handle of a tool energetically press the planking strips against the deck, making sure they are firmly glued in place. Place the deck upside down on your work surface and trim off all of the excess planking strips. Now mark a series of lines and dots to simulate a planking effect and sand the deck down before applying a coat of pore-filler lacquer.

**B:** Glue the deck (**A19**), now lined, onto the structure of the ship. It is important to ensure that the deck is resting correctly on the frames. Sand down the top of the fore and aft frames and the profiles of the decks using a sanding block. This operation will prepare the surfaces for the attachment of the bulwarks. For this process use fast-setting glue. Now soak parts (**B1**) in water, so that they recover their flexibility and, using a cylindrical object, bend them to shape, making sure that you don’t break them. Adapt and glue parts B1 into place using white glue and pins. The nailer is an (optional) OcCre tool, which can be used to simultaneously hold and drive home the pins, or nails.

**C-D:** Place the hull upside down and start to sand it, working from the bow towards the stern. You must sand down the reinforcements and the edges of the frames, although without deforming their original shape. The sanding down of the hull must be symmetrical, i.e. the right side must end up the same as the left side. In the middle of the hull use a sanding block with a bigger surface area. Sanding down needs to be done progressively and gently. Line up a strip to ensure that the sanded finish is correct. To this end you should slide the strip over the edges of the frames to verify that it adapts to the form. Take the strips (**C1**) and soak them in water for around 20 minutes, which will enable them to recover a certain flexibility. Start to line the hull by fitting first strip flush up against the bottom of the bulwarks. Check the images before going ahead with this operation. The strips must be glued to the frames and to each other, using white glue, and then fixed in place using pins.

Now glue another strip alongside the first, and so on all the way to the stern. Continue with this process until you have lined the whole of the hull. You will have to cut the strips to size and adjust the parts so that they fit into the gaps.

If, at any point, you detect that one or more of the strips is loose, correctly align it and apply fast-setting glue. If any of the strips is sunken, in comparison with the others, then glue another one on top of it and sand it down until it is flush. Now glue the reinforcement parts (**D1**), **D2**, **D3**, **D4**, **D5**, **D6**, **D7**, **D8** & **D9**) into place, as shown. File down the pin heads until they are flush with the hull, and then sand down the whole of the hull. Make sure that it presents a smooth finish without variations in level.

**E:** Using contact (cobbler’s) adhesive, glue the lining planks (**E1**) into place. This second layer of planking should be fitted in the same way as the first. Any gaps that may be left must be filled with lengths sharpened at both ends. Press them down firmly so that they stick securely to the hull. As the lining work progresses reopen the original holes in the bulwarks. Make sure that the strips of planking are aligned as close together as possible, to ensure a good finish. Now gently sand down the whole of the hull leaving a uniform surface finish.

**F:** Line the inside of the side with the (**F1**) liner. Prepare and glue the pieces shown in the illustrations. You’ll have to dye some of the pieces with walnut dye. Then apply a layer of colourless top-coat lacquer to the entire hull and the added parts.

**G-H-I:** Prepare and glue the pieces shown in the illustrations. Use template **PL-01** as a guide. Make the decorative pieces of the transom and paint the background blue where the windows will be fitted. If you want to paint the boat, first look at the following illustrations and do not dye those parts you are going to paint. You must sand the parts of the hull that you varnished, so that the paint takes firmly. Use masking tape around the areas you want to paint. Use water-based acrylic paints; white, black, brown, red, etc. It is advisable to sand the pieces to be painted beforehand. Build the deckhouses and varnish them before adding the metal parts.

**J-K:** To make the chains, (**J12**), knot a thread around a deadeye, apply quick-drying glue and cut one of the leftover threads. Then, insert the end of the thread through the chain-wales. Fix the thread to a pin stuck in the hull using a simple knot. To build the boats, insert each frame in the position shown in the illustration, then sand the assembled sets. Use the **IP** sheet to identify the frames of the boats. Dye the boards with some sapelli dye and line the boats’ hulls with them. The first plank should be placed to fit the cut-outs that the frames have on their bottom. Cut the frames by the cut mark and separate them from the base. Dye the pieces sapelli or pine colour to differentiate them. Add the necessary parts to complete the boats.

### MASTS AND SPARS

In order to make up the masts the first step is to cut the rods to size, as indicated in the parts list, or by taking measurements directly from the plans, which are printed in 1/1 scale.

All of the masts and spars have to have a certain conical shape, which they will have to be given.

In order to achieve this conical shape for the masts, sand down the rod (using a sander), increasing the amount of sanding down as you get closer to the end at which you want to decrease the diameter. Turn the rod so that you sand it down evenly on all sides, until achieving the diameter indicated in the plan.

To achieve this conical shape for the spars carry out the above operations but in this case evenly reducing the diameter at both ends of the rod.

The rods will have to be stained or painted, depending on the model that you are building.

To correctly make up the mast for this model you must take into account:

The plans, the close-up photos of the masts and spars, the measurements and material descriptions of the parts list, the “PI” parts identification sheets.

The masts and spars need to be varnished, while some of the parts that make them up are meant to be painted. Examine the general and close-up photos of the masts.

Once the mast and spars has been assembled and varnished fix the tackle (slings, blocks, eyebolts, clump blocks, etc.) into place on the ship. The masts will have to be fully inserted into the sockets prepared to receive them in the false keel.

### SAILS AND RIGGING

In order to make up the running gear for this ship follow the alphabetic order of the images printed on the plans, indicating the order for fitting the (ropes, clump blocks, blocks, sails, etc.) highlighted in red. In combination with the parts list this will serve as a guide with regard to the type of material to be used and the measurements.

A method for simulating the aging of the sails is to soak them in an infusion of tea, without boiling, and then leaving them to dry all wrinkled up. Fit them in place without ironing so that they will have a certain consistency.

## INSTRUCTIONS DE MONTAGE ESSEX

**A-** Introduire et coller les pièces indiquées sur les figures en suivant l'ordre alphanumérique. Avant de coller les couples, vérifier qu'ils s'emboîtent correctement à leur place et qu'ils pénètrent à fond dans les emboîtures de la fausse quille. Il est important que les couples soient parfaitement perpendiculaires à la fausse quille afin que les ponts s'emboîtent correctement par la suite. Pour réaliser cette opération, on utilisera de la colle blanche (colle de menuisier).

Tracer une ligne longitudinale qui divise le pont **A19** en deux moitiés symétriques. Commencer le bordage en plaçant la première latte contre la ligne tracée au crayon. Utiliser de la colle de contact (colle de cordonnier). Frotter énergiquement les plaques contre le pont, à l'aide du manche en bois d'un outil, afin qu'elles y adhèrent fermement. Retourner le pont et couper les excédents des plaques. Tracer ensuite des lignes pour simuler le bordage. Poncer le pont et y appliquer un vernis bouche-pores incolore.

**B-** Coller le pont **A19** bordé sur la structure du bateau. Il est important que le pont repose correctement sur les couples. Poncer la partie supérieure des couples de proue et de poupe, et les profils des ponts à l'aide d'une cale à poncer. Cette opération facilitera l'appui des murailles. On utilisera de la colle rapide pour réaliser cette opération. Plonger les pièces **B1** dans l'eau afin qu'elles récupèrent leur flexibilité. Utiliser un objet cylindrique pour les courber petit à petit en évitant de les briser. Adapter et coller les pièces **B1** avec de la colle blanche et des pointes. La cloueuse est un outil OcCre (option) qui sert à tenir et à clouer en même temps les pointes.

**C-D-** Retourner la coque et la poncer en allant de la proue vers la poupe. Il faut dégrossir les taquets de renfort et les arêtes des couples, mais en veillant à ne pas modifier leur forme originale. Le ponçage de la coque doit être symétrique, c'est-à-dire que le côté droit doit être identique au côté gauche. Pour la zone du milieu de la coque, utiliser une cale à poncer plus grande. Le ponçage doit être progressif et doux. Vérifier à l'aide d'un listeau que le ponçage est correct. À cet effet, faire glisser le listeau sur les couples afin de voir s'il s'adapte bien à leur forme. Prendre les listeaux **C1** et les plonger dans l'eau pendant vingt minutes environ. Cela leur permettra de récupérer leur flexibilité. Commencer le bordage de la coque en ajustant le premier listeau à la partie inférieure de la muraille. Observer les photos suivantes avant de réaliser cette opération. Il faut coller les listeaux sur les couples et entre eux en utilisant de la colle blanche, puis les fixer avec des pointes.

Coller contre le premier listeau un autre listeau qui ira jusqu'à la poupe. Continuer le même processus de sorte à border toute la coque. Il faut couper les pièces sur mesure et les ajuster afin qu'elles s'emboîtent dans les ouvertures.

Si l'on observe une latte lâche, on peut appliquer de la colle à séchage rapide. Si l'on observe une latte enfoncée, on collera une autre latte par-dessus, puis on la dégrossira. Coller les renforts **D1, D2, D3, D4, D5, D6, D7, D8** et **D9**. Limer la tête des pointes de sorte qu'elles soient de niveau avec le bordé. Ensuite, poncer toute la coque. Elle doit être douce et ne pas présenter de dénivellations.

**E-** Placer le bordé **E1** en utilisant de la colle de contact (colle de cordonnier). Placer ce deuxième bordé de la même façon que le premier. Il faut obturer les ouvertures à l'aide de cales et frotter les plaques de façon énergique afin qu'elles adhèrent à la coque. On percera les ouvertures originales des murailles au fur et à mesure que le bordage avancera. Veiller à ce que les bandes de bordé soient les plus proches possible afin d'obtenir une bonne finition. Poncer toute la coque avec du papier de verre à grain fin de sorte à obtenir une surface uniforme.

**F-** Recouvrir l'intérieur des murailles avec le bordé **F1**. Assembler et coller les pièces qui sont indiquées sur les photos. Certaines de ces pièces devront être teintées à l'eau en couleur noyer. Appliquer ensuite une couche de vernis bouche-pores incolore sur toute la coque et sur les pièces ajoutées.

**G-H-I-** Assembler et coller les pièces qui sont indiquées sur les photos. Utiliser le patron **PL-01** comme guide. Assembler les pièces de décoration du tableau et peindre en bleu le fond sur lequel seront posées les fenêtres. Si on souhaite peindre le bateau, on observera d'abord les photos suivantes et on veillera à ne pas teinter les pièces qui seront peintes par la suite. On poncera les zones de la coque qui ont été vernies afin que la peinture accroche correctement. Utiliser un ruban de carrossier pour isoler les zones que l'on veut peindre. Utiliser des peintures acryliques à l'eau de couleur blanche, noire, brune, rouge, etc. On recommande de poncer au préalable les pièces que l'on va peindre. Construire les cabines et les vernir avant d'y ajouter les pièces de métal.

**J-K-** Pour assembler les cadènes **J12**, nouer un fil autour d'un cap de mouton, appliquer de la colle à séchage rapide et couper un des excédents de fil. Ensuite, introduire l'extrémité du fil dans les porte-haubans. Attacher le fil à une pointe clouée dans la coque en faisant un simple nœud. Pour construire les barques, introduire chaque couple dans la position indiquée sur les photos, puis poncer les ensembles obtenus. Utiliser la feuille **IP** pour identifier les couples des barques. Teinter les listeaux en utilisant une teinture à l'eau de couleur sapelli et border avec ceux-ci les coques des barques. Ajuster la première latte de bordé contre les marques de découpe qui se trouvent sur la partie inférieure des couples. Découper les couples sur la marque de découpe, puis les retirer de la base. Teinter les pièces de couleur sapelli ou pin pour différencier les pièces. Ajouter les pièces nécessaires pour compléter les barques.

### MÂTURE

La première chose à faire pour confectionner les mâts est de couper les baguettes aux dimensions indiquées dans la liste des pièces ou de prendre ces mesures directement des plans qui sont imprimés à l'échelle 1/1.

Tous les mâts et les vergues possèdent une certaine conicité qui doit être travaillée.

Pour réaliser la conicité des mâts, poncer les baguettes (avec une ponceuse) en augmentant le dégrossissage au fur et à mesure qu'on s'approche de l'extrémité où l'on souhaite diminuer le diamètre. Faire rouler la baguette afin que l'usure soit égale sur tout le contour jusqu'à ce qu'on obtienne le diamètre indiqué sur le plan.

Effectuer les mêmes opérations pour réaliser la conicité des vergues mais, dans ce cas, aux deux extrémités de la baguette.

Il faudra teinter ou peindre les baguettes en fonction de la maquette qui sera construite.

Pour réaliser correctement les mâts de cette maquette, il faudra tenir compte :

Des plans, des photos de détail des mâts, des dimensions et de la description des matériaux de la liste des pièces, des feuilles « IP » d'identification des pièces.

Les mâts devront être vernis et certaines des pièces qui les composent devront être peintes. Voir les photos générales de détail des mâts.

Lorsque les mâts seront montés et vernis, on placera leurs appareils (estropes, moufles, pitons, poulies, etc.) et on les attachera au bateau. Les mâts doivent être introduits de sorte qu'ils s'emboîtent à fond contre la fausse quille.

### GRÉEMENT

Pour réaliser le gréement de ce bateau, on suivra l'ordre alphabétique des figures imprimées des plans, qui indiquent l'ordre de montage (fils, caps de mouton, poulies, etc.) mis en évidence en rouge. La liste des pièces indique le type de matériaux et les dimensions à utiliser.

Pour simuler le vieillissement des voiles, on peut les faire tremper dans une infusion de thé, sans les faire bouillir, et les laisser sécher bien chiffonnées. Les voiles seront placées non repassées afin d'avoir du volume.

## ISTRUZIONI DI MONTAGGIO ESSEX

**A-** Seguendo l'ordine alfanumerico, inserire e incollare i pezzi indicati nelle figure. Prima di incollare le coste, verificare che si inseriscano correttamente e fino in fondo nelle corrispondenti sedi della falsa chiglia. È importante che le coste siano perfettamente perpendicolari alla falsa chiglia in modo che i ponti si adattino bene in seguito. Per realizzare questa operazione, utilizzare colla bianca (colla da falegname) come adesivo. Tracciare una linea longitudinale che divida il ponte **A19** in due metà simmetriche. Iniziare a rivestire collocando la prima striscia sulla linea tracciata a matita. Utilizzare una colla a contatto (colla per scarpe) come adesivo. Utilizzando il manico di legno di un utensile, strofinare le lastre contro il ponte in modo tale che aderiscano saldamente. Capovolgere il ponte per ritagliare le parti di lastre che avanzino. Quindi, tracciare delle righe per simulare il fasciame. Scartavetrare il ponte e applicare la lacca tappa pori incolore.

**B-** Incollare il ponte **A19** già rivestito sulla struttura del vascello. È importante che il ponte sia correttamente appoggiato sulle coste. Scartavetrare la parte superiore delle coste di prua e di poppa e i profili dei ponti, utilizzando una smerigliatrice. Con questa operazione si faciliterà l'appoggio delle mure. Per realizzare questa operazione, utilizzare una colla a presa rapida. Introdurre i pezzi **B1** in acqua, affinché acquistino una certa flessibilità. Utilizzare un qualsiasi oggetto cilindrico per dargli la curvatura poco a poco, senza romperli. Adattare e incollare i pezzi **B1** con colla bianca e chiodini. La chiodatrice è un utensile OcCre (opzionale), che si utilizza per sostenere e inchiodare i chiodini allo stesso tempo.

**C-D-** Collocare lo scafo al rovescio e iniziare a scartavetrare cominciando dalla prua e andando verso la poppa. Si devono levigare i tasselli di rinforzo e gli angoli delle coste, ma senza deformarne la loro forma originale. La scartavetratura dello scafo deve dare un risultato simmetrico, quindi il costato destro deve essere uguale a quello sinistro. Per la zona centrale dello scafo, utilizzare una carta vetrata con maggior superficie. La levigatura deve essere progressiva e delicata. Controllare con una listarella che la levigatura sia corretta. Per realizzare questa operazione, si deve far passare la listarella sulle coste per verificare come si adatta alla loro forma. Prendere le listarelle **C1** e immergerle in acqua per circa 20 minuti, in maniera tale che acquistino flessibilità. Iniziare a rivestire lo scafo adattando la prima listarella alla parte inferiore della murata. Osservare le immagini seguenti prima di iniziare il lavoro. Bisogna incollare le listarelle alle coste, e tra loro, con colla bianca, e fissarle con i chiodini.

Incollare una listarella dopo l'altra, a seguito della prima, fino ad arrivare alla poppa. Realizzare la stessa operazione fino a ricoprire tutto lo scafo. I pezzi devono essere ritagliati su misura e adattati affinché ricoprano tutti gli spazi vuoti.

Se in qualche punto è rimasta qualche listarella non ben aderita, si può applicare una colla ad asciugatura rapida. Se qualche listarella è rimasta un po' affondata, si può incollarne un'altra sopra e poi scartavetrare. Incollare i rinforzi **D1, D2, D3, D4, D5, D6, D7, D8 e D9**. Scartavetrare le testine dei chiodini finché non siano a filo con il rivestimento. Poi, levigare tutto lo scafo. Il risultato finale deve essere una superficie liscia e senza dislivelli.

**E-** Utilizzando come adesivo una colla a contatto, (colla da calzolaio), collocare il rivestimento **E1**. Questo secondo rivestimento si colloca allo stesso modo del primo. Si devono chiudere le fessure con cunei e fregare le piastre con forza affinché aderiscano bene allo scafo. A misura che si avanzi con il rivestimento, aprire i fori che le murate presentano in origine. Fare attenzione che le listarelle di rivestimento siano il più possibile unite, per ottenere una buona finitura. Levigare tutto lo scafo con una carta vetrata a grana fine per ottenere una superficie uniforme.

**F-** Rivestire l'interno dei bastioni con il fasciame **F1**. Elaborare e incollare i pezzi che indicano le immagini. Alcuni pezzi devono essere verniciati con vernice a base d'acqua di color noce. Applicare quindi uno strato di impregnante tappa pori trasparente su tutto lo scafo e sulle parti aggiunte.

**G-H-I-** Preparare e incollare i pezzi indicati nelle immagini. Utilizzare il modello **PL-01** come guida. Preparare i pezzi di decorazione dello specchio e verniciare in blu lo sfondo dove dovranno essere collocate le finestre. Se si desidera verniciare la nave, si consiglia di osservare le seguenti immagini in anticipo e di non tintecciare i pezzi che si voglia dipingere. Scartavetrare le zone dello scafo che sono state smaltate, in modo che la pittura si possa imprimere in maniera sicura. Usare nastro da carrozziere per isolare le parti che si voglia verniciare. Per il processo di verniciatura, utilizzare vernici acriliche a base d'acqua: bianco, nero, marrone, rosso, ecc. Si consiglia di scartavetrare preventivamente i pezzi che si voglia dipingere. Costruire le cabine e verniciarle prima di aggiungervi i pezzi di metallo.

**J-K-** Per realizzare le lande delle sartie, **J12**, annodare un filo intorno ad una bigotta, applicare la colla ad asciugatura rapida e tagliare uno dei fili in eccesso. Quindi, inserire l'estremità del filo attraverso le tavole di guarnizione. Fissare il filo ad un chiodo inchiodato allo scafo, facendo un nodo semplice. Per costruire le barche, inserire ogni costa nella posizione indicata dalle immagini, quindi scartavetrare i pezzi ottenuti. Utilizzare il modello **IP** per identificare le coste delle imbarcazioni. Verniciare le aste con verni a base d'acqua di color sapelli colorante e rivestire con le stesse gli scafi delle barche. La prima striscia di rivestimento deve essere posizionata lungo i segni di taglio che le coste presentano nella loro parte inferiore. Tagliare le coste lungo il segno di taglio e staccarle dalla base. Verniciare i pezzi in color sapelli o pino per differenziare i pezzi. Aggiungere i pezzi necessari per completare le barche.

### ALBERATURA

Per realizzare l'alberatura, il primo passo da seguire sarà quello di tagliare le aste secondo le misure indicate nell'elenco dei pezzi, oppure prenderle direttamente dalle planimetrie che sono stampate in scala 1/1.

Tutti gli alberi e i pennoni hanno una certa conicità che si dovrà ottenere.

Per ottenere la conicità degli alberi, occorre scartavetrare le aste (con una smerigliatrice), aumentando l'azione della stessa a misura che ci si avvicina all'estremità dove si deve diminuire il diametro. Far girare l'asta affinché la smerigliatura sia uguale su tutto il contorno, fino ad arrivare al diametro indicato nella planimetria.

Per ottenere la conicità dei pennoni, realizzare le stesse operazioni, ma in questo caso su entrambe le estremità dell'asta. Si dovranno verniciare o tingere le aste in funzione del modello che si stia realizzando.

Per realizzare gli alberi di questo modello in maniera corretta si dovranno utilizzare:

Le planimetrie; le foto dettagliate degli alberi; le misure e la descrizione dei materiali nell'elenco dei pezzi; le pagine "IP" con l'identificazione dei pezzi.

Gli alberi devono essere smaltati ed alcuni dei pezzi che li compongono devono essere verniciati. Vedi le foto generali dettagliate degli alberi.

Una volta montati e smaltati, devono essere collocati gli attrezzi (stroppi, quarnali, golfare, bozzelli, ecc.) e fissati al vascello. Gli alberi devono essere introdotti fino in fondo negli appositi incastri della falsa chiglia.

### SARTIA

Per elaborare la sartia di questo vascello occorre seguire l'ordine alfabetico delle figure stampate delle planimetrie, che indicano l'ordine di collocazione delle cime, delle bigotte, dei bozzelli, delle vele, ecc., risaltati in colore rosso. L'elenco dei pezzi serve ad orientare in merito al tipo di materiali ed alle misure da utilizzare.

Per simulare l'invecchiamento delle vele, queste possono essere bagnate con te, senza farle bollire, e poi lasciarle asciugare mantenendole ben arrugate. Poi si collocano senza stirarle, affinché mantengano corpo.

## BASTELANLEITUNG ESSEX

**A-** Die auf den Abbildungen gezeigten Teile in der angegebenen Reihenfolge einsetzen und aufkleben. Vor dem Aufkleben der Spanten sicherstellen, dass die sie korrekt sitzen und mit den dazugehörigen Einkerbungen des falschen Kiels abschließen. Die Spanten müssen vollkommen senkrecht auf dem falschen Kiel stehen, damit danach die Decks gut eingesetzt werden können. Für diese Operation muss weißer Kleber (Tischlerleim) verwendet werden.

Eine Längslinie ziehen, mit der das Deck **A19** in zwei symmetrische Hälften geteilt wird. Dabei die erste Plankenreihe an der Bleistiftlinie ausrichten. Zum Kleben Kontaktkleber verwenden (Schusterleim). Mit dem Holzstiel eines Werkzeugs das Furnier kräftig auf das Deck reiben, bis es fest haftet. Das Deck mit der Oberseite nach unten aufsetzen und die überstehenden Teile der Leisten abschneiden. Abschließend Linien ziehen und Markierungen anbringen, um die Schiffsbeplankung zu simulieren. Das Deck glatt schmirgeln und mit porenschließendem Klarlack behandeln.

**B-** Das beplankte Deck **A19** auf die Struktur des Schiffes kleben. Dabei darauf achten, dass das Deck richtig auf den Spanten sitzt. Schleifen Sie die Oberseite der Bug- und Heckspanten und der Deckprofile mit einem Schleifblock. Dadurch lässt sich die Schanzverkleidung besser aufsetzen. Dazu Sekundenkleber verwenden. Die Schotts an Bug und Heck bauen und beplanken. Die Teile **B1** in Wasser einweichen, damit sie biegsamer werden. Die Teile dann vorsichtig mit einem zylinderförmigen Gegenstand formen. Die Teile **B1** anpassen und mit weißem Leim und Stiften anbringen. Der Nagler ist ein von OcCre als Zubehör angebotenes Werkzeug, um die Stifte festzuhalten und gleichzeitig festzunageln.

**C-D-** Den Rumpf mit der Oberseite nach unten anbringen und vom Bug in Richtung Heck glattschmirgeln. Die Verstärkungskeile und die Kanten der Spanten glätten, aber dabei nicht die ursprüngliche Form verändern. Beim Glätten des Rumpfs darauf achten, dass beide Seiten symmetrisch zueinander sein müssen. Für den mittleren Rumpfbereich einen Sander mit großer Schleifoberfläche verwenden. Die Oberfläche nach und nach vorsichtig glätten.

Mit der Leiste testen, ob eine gleichmäßige Oberfläche hergestellt wurde. Dazu die Leiste über die Spanten fahren und prüfen, wie sie sich der Form anpasst. Die Leisten **C1** ca. 20 Minuten in Wasser einweichen, damit sie biegsam werden. Mit der Wegerung des Schiffsrumpfs beginnen und dazu die erste Leiste an der Unterseite der Schanzverkleidung ankleben. Vor dem Weitermachen die Abbildungen beachten. Die Leisten an die Spanten kleben und dazwischen mit weißem Leim die Stifte ankleben.

Eine weitere Leiste neben die erste kleben und auf dieselbe Weise bis zum Heck fortfahren. Den ganzen Rumpf auf diese Weise beplanken. Die Teile für die Zwischenräume nach Maß zurechtschneiden.

Lose Planke mit Sekundenkleber festkleben. Wenn eine Planke zu tief sitzen sollte, eine weitere Planke darüber kleben und anschließend nachbearbeiten. Die Verstrebungen **D1, D2, D3, D4, D5, D6, D7, D8** und **D9** aufkleben. Die Stiftköpfe glattfeilen, bis sie auf einer Höhe mit den Plankenreihen sind. Anschließend den gesamten Rumpf glatt schmirgeln. Es muss eine glatte und gleichmäßige Oberfläche entstehen.

**E-** Kontaktkleber (Schusterleim) verwenden, um die Beplankung **E1** aufzukleben. Diese zweite Beplankung wird auf die gleiche Weise wie die erste verlegt. Die Zwischenräume mit Schlusskeilen abschließen und die Leisten fest andrücken, damit sie am Rumpf anhaften. Die Planken, die die Öffnungen der Schanzverkleidung verdecken, während des Wegerns nach und nach öffnen. Für ein gleichmäßiges Finish darauf achten, dass die Plankenreihen so nah wie möglich nebeneinander sitzen. Danach die Teile vorsichtig mit feinem Schmirgelpapier bearbeiten, so dass eine gleichmäßige Oberfläche entsteht.

**F-** Die Innenseite der Schanzverkleidung mit **F1**-Beplankung auskleiden. Die Teile, die auf den Abbildungen zu sehen sind, anfertigen, lackieren und ankleben. Einige der Stücke müssen mit Wasserfarbe in Nussbaumholz gefärbt werden. Anschließend den gesamten Rumpf und die hinzugefügten Teile mit farblosem porenschließendem Lack behandeln.

**G-H-I-** Die Teile, die auf den Abbildungen zu sehen sind, anfertigen, lackieren und ankleben. Dazu als Hilfe die Schablone **PL-01** verwenden. Die Teile zur Dekoration des Spiegels anfertigen und den Untergrund, auf dem die Fenster angebracht werden blau anmalen. Soll das Boot lackiert werden, die folgenden Abbildungen beachten und die Teile, die lackiert werden sollen, nicht färben. Die Bereiche des Rumpfes, die lackiert werden sollen, anschleifen, damit die Farbe besser einzieht. Die zu lackierenden Stellen mit Klebeband abkleben. Dazu Acrylfarbe auf Wasserbasis verwenden. Farben: weiß, schwarz, braun, rot usw. Die Teile, die lackiert werden sollen, vorher etwas anschleifen. Die Aufbauten anfertigen und lackieren, bevor die Metallteile angebracht werden.

**J-K-** Um die Wantleisten **J12** anzufertigen, einen Draht um einen Klampbock winden, Sekundenkleber auftragen und eines der überstehenden Enden des Drahts abschneiden. Anschließend das Ende des Drahts durch Backs ziehen. Den Draht mit einem einfachen Knoten an einem Stift auf dem Rumpf befestigen. Um die Boote zu bauen, die einzelnen Spanten wie auf den Abbildungen gezeigt zusammensetzen und danach glattschmirgeln. Die Spanten der Boote anhand des **IP**-Blatts herausuchen. Leisten in Sapelly-Holz oder einer ähnlichen Farbe auf Wasserbasis färben und damit den Rumpf der Boote verkleiden. Die erste Leiste der Verkleidung bündig an die Schnittmarkierungen an den Unterseiten der Spanten anbringen. Die Spanten an der Schnittmarkierung abschneiden und vom Unterbau trennen. Die Teile in Sapelly-Holz oder Kiefer färben, damit sich die Teile farblich abheben. Die notwendigen Teile zum Vervollständigen der Boote anbringen.

### BEMASTUNG

Zur Herstellung der Masten müssen zuerst die Stäbe entsprechend der Maße zurecht geschnitten werden, die in der Teileliste angegeben sind oder die direkt anhand der Skizze abgemessen wurde. Die Skizzen sind im Maßstab 1/1 angefertigt.

Alle Masten und Rahen müssen leicht konisch verlaufen und vor dem Einbau entsprechen vorbereitet werden.

Um die Masten in Konusform zu bringen, müssen die Masten (mit einer Feile) zurecht geschliffen werden, und zwar in der Form, dass sie nach oben hin verjüngt werden. Die Stäbe dabei drehen und an allen Seiten gleichmäßig abschleifen, bis sie zu dem auf der Skizze angegebenen Durchmesser passen.

Um die Rahen in Konusform zu bringen, ebenso verfahren, allerdings hier an beiden Enden der Stangen.

Die Stäbe in Abhängigkeit von dem Modell färben oder anmalen.

Um die Masten dieses Schiffsbaumodells richtig vorzubereiten, müssen die folgenden Punkte beachtet werden:

Die Skizzen, detailfotos der Masten, maße und Materialien der Teileliste, IP-Blätter zur Identifikation der Bauteile.

Die Masten müssen lackiert werden und einige der Einzelteile der Masten müssen angemalt werden. Siehe Fotos mit allgemeiner Ansicht der Masten

Nach Aufstellung und Lackierung der Masten wird die Takelung (Stroppe, Rollenblöcke, Ösen, Blockrollen etc.) an den Masten und dann am Schiff befestigt. Die Masten müssen eingesetzt werden, bis sie an die Einkerbungen des falschen Kiels stoßen.

### TAKELAGE

Zur Takelung des Schiffsmodells die alphabetische Reihenfolge der Abbildungen befolgen, auf denen die Anbringung der Takelung (Faden, Klampböcke, Blockrollen usw.) erläutert wird. Sie sind in Rot hervorgehoben. Auf der Teileliste sehen Sie, welche Materialien zum Bau des Modells notwendig sind.

Zur künstlichen Alterung der Segel die Stoffstücke in Tee legen (nicht kochen) und trocknen lassen, bis die Stoffe faltig werden. Die Segel ohne vorheriges Bügeln anbringen, damit sie Volumen haben.

**A-** Следуя указанному буквами и цифрами порядку, вставьте и приклейте детали, указанные на рисунках. Перед тем как нанести клей на шпангоуты, проверьте правильность их пригонки к соответствующим пазам фальшкиля. Очень важно обеспечить полную перпендикулярность шпангоутов к фальшкилю, чтобы впоследствии можно было установить правильно палубы. Для этой операции используйте в качестве клеящего средства белый клей (столярный клей).

Нанесите продольную линию, разделяющую палубу **A19** на две симметричные половины. Приступите к обшивке, пригоняя первую полосу к нанесенной карандашом линии. Используйте в качестве клеящего вещества контактный клей (сапожный клей). Деревянной ручкой какого-нибудь инструмента притрите с силой пластины к палубе, чтобы они прочно прикрепились. Положите палубу верхом книзу и обрежьте лишние части пластин. Затем начертите несколько линий, чтобы обозначить настил. Зачистите палубу и нанесите на нее бесцветный порозаполняющий лак.

**B** - Приклейте обшитую палубу **A19** к структуре корабля. Важно, чтобы палуба как следует опиралась на шпангоуты. Зачистите верхнюю часть носовых и кормовых шпангоутов и профили палуб, пользуясь наждачным бруском. Эта операция облегчает опору фальшбортов. Для этого процесса используйте быстродействующий клей. Поместите детали **B1** в воду, чтобы восстановить их гибкость. Используя цилиндрический предмет, осторожно согните их, не допуская разлома. Приладьте и приклейте детали **B1**, используя белый клей и гвоздей. Гвоздильный молоток является инструментом **OsCre** (дополнительным), который используется для удержания и одновременно прибавления гвоздей.

**C - D-** Положите корпус верхом книзу и начните зачистку, продвигаясь от носа к корме. Вам нужно обтесать подпорки усиления и выступы шпангоутов, не нарушая при этом их изначальную форму. Результат зачистки должен быть симметричным, то есть, правая боковина должна быть равна левой. Для центральной зоны корпуса используйте шлифовальный брусок с большей поверхностью. Зачистка должна производиться поступательно и без нажима.

При помощи планки проверьте правильность шлифовки. Для этого вам нужно провести планкой по шпангоутам, убеждаясь, что они соответствуют его форме. Возьмите планки **C1** и погрузите их в воду примерно на двадцать минут. Эта операция восстановит их гибкость.

Начните обшивку корпуса, пригнав первую планку к нижней части фальшборта. Перед исполнением ознакомьтесь со следующими изображениями. Вам нужно приклеить планки к шпангоутам и друг к другу при помощи белого клея и закрепить их гвоздями.

Приклейте следующую планку, следуя за первой, до самой кормы. Повторяйте те же действия для обшивки всего корпуса. Вам нужно вырезать по размеру и пригнать детали, чтобы они правильно входили в отверстия.

Если в каком-нибудь месте осталась отошедшая планка, вы можете нанести клей быстрого высыхания. Если какая-нибудь планка оказалась впавшей, наклейте сверху другую, а затем затешите ее. Наклейте усиления **D1, D2, D3, D4, D5, D6, D7, D8** и **D9**. Зачистите головки гвоздей, чтобы.

**E** - Используя в качестве клеящего средства контактный клей (сапожный клей), установите обшивку **E1**. Эта вторая обшивка устанавливается таким же способом, как и первая. Вам нужно закрывать полости клиньями и с усилием притирать пластины, чтобы они были вплотную к корпусу. По мере выполнения обшивки открывайте отверстия, изначальные имеющиеся в фальшборте. Следите за тем, чтобы полосы обшивки находились как можно ближе друг к другу, чтобы облицовка была хорошего качества. Отшлифуйте весь корпус мелкозернистой шкуркой, чтобы поверхность была ровной.

**F-** Обшейте внутреннюю сторону фальшбортов обшивкой **F1**. Изготовьте и приклейте детали, как показано на рисунках. Некоторые детали будут нужно окрасить водяным красителем орехового цвета. Затем нанесите слой бесцветного порозаполняющего лака на весь корпус и добавленные детали.

**G-H-I** - Изготовьте и приклейте детали, как показано на рисунках. В качестве направляющей используйте шаблон **PL-01**. Изготовьте декоративные детали транцевой кормы и покрасьте в синий цвет места, в которых будут размещаться окна. Если вы желаете покрасить судно предварительно ознакомьтесь со следующими рисунками и не окрашивайте детали, которые вы будете красить. Те зоны корпуса, которые вы лакировали, нужно будет зачистить для прочного сцепления краски с поверхностью. Используйте малярный скотч для ограничения зон, которые вы желаете покрасить. Для покраски используйте акриловые краски на воде: белую, черную, коричневую, красную и т.д. Рекомендуется предварительно зачистить детали, которые вы будете красить. Соорудите будки и покройте их лаком до добавления к ним металлический деталей.

**J-K** - Для изготовления талрепов **J12** завяжите нить вокруг юферса, нанесите быстродействующий клей и отрежьте один из концов нити. Затем протяните конец нити через руслени. Прикрепите нить к вбитому в корпусу гвоздю простым узлом. Для изготовления шлюпок вставьте каждый шпангоут в положении, указанном на изображениях, затем зачистите получившиеся сборки. Используйте лист **IP** для определения шпангоутов шлюпок. Окрасьте планки водяным красителем цвета сапелли и обшейте ими корпуса шлюпок. Первая полоска обшивки должно устанавливаться вплотную к разметкам обрезки, имеющимся на шпангоутах в нижней части. Обрежьте шпангоуты по разметкам обрезки и отделите их от основания. Окрасьте детали в цвет сапелли или сосновый, чтобы детали различались. Добавьте необходимые детали для завершения шлюпок.

### МАЧТЫ И РЕИ

Для подготовки мачт в первую очередь нужно нарезать стержни по размерам, указанным в перечне деталей, или взять их непосредственно с чертежей, напечатанных в масштабе 1:1.

Все мачты и реи обладают определенной конусностью, которую им нужно придать.

Для придания мачтам конусности, отшлифуйте стержни (наждачным бруском), увеличивая их стирание к тому концу, где требуется меньший диаметр. Поворачивайте стержень, чтобы стирание было одинаковым по всему контуру до получения диаметра, указанного на чертеже.

Для придания конусности реям выполните те же операции, но в этом случае на обоих концах стержня.

Вам нужно будет придать цвет или покрасить стержни в зависимости от изготавливаемой модели.

Для правильного изготовления мачт этой модели нужно принимать во внимание:

Чертежи

Подробные фотографии мачт

Размеры и описание материалов в перечне деталей

Листы "IP" с идентификацией деталей

Мачты нужно покрыть лаком, а отдельные составляющие их детали должны быть покрашены. Рассмотрите общие фотографии с подробностями мачт.

После того как они смонтированы и покрыты лаком, нужно установить на них оснастку (стропы, блоки, рым-болты, блоки и т.д.) и укрепить их на корабле. Мачты должны вставляться до упора в пазы фальшкиля.

### ТАКЕЛАЖ

Для изготовления такелажа данного корабля следуйте в алфавитном порядке фигурам на чертежах, которые указывают порядок установки: канатов, юферсов, блоков, парусов, которые выделены красным цветом. Перечень деталей содержит сведения по виду применяемых материалов и размерам.

**Lista de piezas / Parts List / Liste des pièces / Teileliste / Elenco delle parti**

<b>Nº/No./ N° / Nr. No</b>	<b>Cantidad / Quantity / Quantité / Menge / Quantità</b>	<b>Medidas / Measurements / Dimensions / Maße / Misure</b>	<b>Material / Material / Matériau / Material / Materiale</b>
A1	1	Precortado / Precut / Prédécoupé / Vorgeschnitten / Pretagliatto / Pretagliatto	Tablero / Plywood / Planche / Sperrholz / Tavola
A2 - A12	11	Precortado / Precut / Prédécoupé / Vorgeschnitten / Pretagliatto / Pretagliatto	Tablero / Plywood / Planche / Sperrholz / Tavola
A13	1	Precortado / Precut / Prédécoupé / Vorgeschnitten / Pretagliatto / Pretagliatto	Tablero / Plywood / Planche / Sperrholz / Tavola
A14	2	Precortado / Precut / Prédécoupé / Vorgeschnitten / Pretagliatto / Pretagliatto	Tablero / Plywood / Planche / Sperrholz / Tavola
A15-A16	4	Precortado / Precut / Prédécoupé / Vorgeschnitten / Pretagliatto / Pretagliatto	Tablero / Plywood / Planche / Sperrholz / Tavola
A17-A18	4	Precortado / Precut / Prédécoupé / Vorgeschnitten / Pretagliatto / Pretagliatto	Tablero / Plywood / Planche / Sperrholz / Tavola
A19	1	Precortado / Precut / Prédécoupé / Vorgeschnitten / Pretagliatto / Pretagliatto	Tablero / Plywood / Planche / Sperrholz / Tavola
A20	21	0,6x5x450	Tilo / Lime wood / Tilleul / Linde / Tiglio
B1	2	Precortado / Precut / Prédécoupé / Vorgeschnitten / Pretagliatto	Tablero / Plywood / Planche / Sperrholz / Tavola
C1	48	2x5x600	Tilo / Lime wood / Tilleul / Linde / Tiglio
D1 - D6	12	Precortado / Precut / Prédécoupé / Vorgeschnitten / Pretagliatto / Pretagliatto	Tablero / Plywood / Planche / Sperrholz / Tavola
D7 - D13	14	Precortado / Precut / Prédécoupé / Vorgeschnitten / Pretagliatto / Pretagliatto	Tablero / Plywood / Planche / Sperrholz / Tavola
E1	58	0,6x5x600	Sapelly / Sapelli / Sapelli / Sapelly-Holz / Sapelli
F1	10	0,6x5x600	Sicomoro / Sycamore / Sycomore / Bergahorn / Sicomoro
F2	2	Precortado / Precut / Prédécoupé / Vorgeschnitten / Pretagliatto / Pretagliatto	Tablero / Plywood / Planche / Sperrholz / Tavola
F3	2	2x3x330	Tilo / Lime wood / Tilleul / Linde / Tiglio
F4	14	2x2x10	Tilo / Lime wood / Tilleul / Linde / Tiglio
F5	14	2x2x20	Tilo / Lime wood / Tilleul / Linde / Tiglio
F6	2	Precortado / Precut / Prédécoupé / Vorgeschnitten / Pretagliatto / Pretagliatto	Tablero / Plywood / Planche / Sperrholz / Tavola
F7	2	2x5x122	Tilo / Lime wood / Tilleul / Linde / Tiglio
F8	2	2x5x14	Tilo / Lime wood / Tilleul / Linde / Tiglio
F9	2	2x5x215	Tilo / Lime wood / Tilleul / Linde / Tiglio
F10	3	Preformado / Preformed/ Préformé / Vorgeformt / Preformato / Preformato	Madera / Wood / Bois / Holz / Legno
F11	2	2x2x220	Tilo / Lime wood / Tilleul / Linde / Tiglio
F12 - F13	4	2x2x600	Tilo / Lime wood / Tilleul / Linde / Tiglio
F14	1	Precortado / Precut / Prédécoupé / Vorgeschnitten / Pretagliatto / Pretagliatto	Tablero / Plywood / Planche / Sperrholz / Tavola
F15	1	Precortado / Precut / Prédécoupé / Vorgeschnitten / Pretagliatto / Pretagliatto	Tablero / Plywood / Planche / Sperrholz / Tavola
F16 - F17	2	Precortado / Precut / Prédécoupé / Vorgeschnitten / Pretagliatto / Pretagliatto	Tablero / Plywood / Planche / Sperrholz / Tavola
F18	1	Precortado / Precut / Prédécoupé / Vorgeschnitten / Pretagliatto / Pretagliatto	Tablero / Plywood / Planche / Sperrholz / Tavola
F19	1	Precortado / Precut / Prédécoupé / Vorgeschnitten / Pretagliatto / Pretagliatto	Tablero / Plywood / Planche / Sperrholz / Tavola
G1	1	Precortado / Precut / Prédécoupé / Vorgeschnitten / Pretagliatto / Pretagliatto	Tablero / Plywood / Planche / Sperrholz / Tavola
G2	5	0,6x5x85	Tilo / Lime wood / Tilleul / Linde / Tiglio
G3	1	Precortado / Precut / Prédécoupé / Vorgeschnitten / Pretagliatto	Tablero / Plywood / Planche / Sperrholz / Tavola
G4	2	2x2x15	Sapelly / Sapelli / Sapelli / Sapelly-Holz / Sapelli
G5	1	2x2x85	Tilo / Lime wood / Tilleul / Linde / Tiglio
G6	22	0,6x5x60	Sapelly / Sapelli / Sapelli / Sapelly-Holz / Sapelli
G7	1	Precortado / Precut / Prédécoupé / Vorgeschnitten / Pretagliatto	Tablero / Plywood / Planche / Sperrholz / Tavola
G8-G9	4	ø1,5x100	Latón / Brass / Latón / Messing / Ottone
G10	4	Preformado / Preformed/ Préformé / Vorgeformt / Preformato	Latón / Brass / Latón / Messing / Ottone
G11	1	ø1,5x100	Latón / Brass / Latón / Messing / Ottone
G12	2	Preformado / Preformed/ Préformé / Vorgeformt / Preformato	Latón / Brass / Latón / Messing / Ottone
G13	1	Precortado / Precut / Prédécoupé / Vorgeschnitten / Pretagliatto	Tablero / Plywood / Planche / Sperrholz / Tavola
G14	6	Preformado / Preformed/ Préformé / Vorgeformt / Preformato	Latón / Brass / Latón / Messing / Ottone
G15	3	ø1,5x5	Latón / Brass / Latón / Messing / Ottone
G16	2	2x5x12	Tilo / Lime wood / Tilleul / Linde / Tiglio
G17	2	2x5x38	Tilo / Lime wood / Tilleul / Linde / Tiglio
G18	2	2x5x43	Tilo / Lime wood / Tilleul / Linde / Tiglio
G19	2	Precortado / Precut / Prédécoupé / Vorgeschnitten / Pretagliatto	Tablero / Plywood / Planche / Sperrholz / Tavola
G20	22	3x3x9	Tilo / Lime wood / Tilleul / Linde / Tiglio
G21	1	2x5x124	Tilo / Lime wood / Tilleul / Linde / Tiglio
G22	1	2x5x80	Tilo / Lime wood / Tilleul / Linde / Tiglio
G23	1	2x2x11	Tilo / Lime wood / Tilleul / Linde / Tiglio
G24	1	2x5x39	Tilo / Lime wood / Tilleul / Linde / Tiglio
G25	2	3x3x7	Tilo / Lime wood / Tilleul / Linde / Tiglio
G26	2	4x4x15	Tilo / Lime wood / Tilleul / Linde / Tiglio
G27	2	2x4x25	Tilo / Lime wood / Tilleul / Linde / Tiglio
H1-H5	6	Precortado / Precut / Prédécoupé / Vorgeschnitten / Pretagliatto	Tablero / Plywood / Planche / Sperrholz / Tavola
H6	14	0,6x5x30	Sicomoro / Sycamore / Sycomore / Bergahorn / Sicomoro
H7	4	0,6x5x20	Sapelly / Sapelli / Sapelli / Sapelly-Holz / Sapelli
H8	2	1x3x13	Tilo / Lime wood / Tilleul / Linde / Tiglio
H9	2	1x3x16	Tilo / Lime wood / Tilleul / Linde / Tiglio
H10	2	1x5x20	Tilo / Lime wood / Tilleul / Linde / Tiglio
H11	2	2x2x4	Sapelly / Sapelli / Sapelli / Sapelly-Holz / Sapelli
H12	2	2x2x14	Sapelly / Sapelli / Sapelli / Sapelly-Holz / Sapelli
H13	1	2x2x17	Sapelly / Sapelli / Sapelli / Sapelly-Holz / Sapelli
H14	1	Precortado / Precut / Prédécoupé / Vorgeschnitten / Pretagliatto	Tablero / Plywood / Planche / Sperrholz / Tavola
H15	2	0,6x5x20	Sapelly / Sapelli / Sapelli / Sapelly-Holz / Sapelli
H16	2	ø1x15	Latón / Brass / Latón / Messing / Ottone
H17	4	ø1x3	Latón / Brass / Latón / Messing / Ottone
H18	1	Preformado / Preformed/ Préformé / Vorgeformt / Preformato	Metal / Metal / Metal / Metall / Metallo
H19-H20	4	Precortado / Precut / Prédécoupé / Vorgeschnitten / Pretagliatto	Tablero / Plywood / Planche / Sperrholz / Tavola













**Lista de piezas / Parts List / Liste des pièces / Teileliste / Elenco delle parti**

<b>Nº/No./ Nº / Nr. No</b>	<b>Cantidad / Quantity / Quantité / Menge / Quantità</b>	<b>Medidas / Measurements / Dimensions / Maße / Misure</b>	<b>Material / Material / Matériau / Material / Materiale</b>
H21-H26	7	Precortado / Precut / Prédécoupé / Vorgeschnitten / Pretagliatto	Tablero / Plywood / Planche / Sperrholz / Tavola
H27-H28	6	Precortado / Precut / Prédécoupé / Vorgeschnitten / Pretagliatto	Tablero / Plywood / Planche / Sperrholz / Tavola
H29	1	Precortado / Precut / Prédécoupé / Vorgeschnitten / Pretagliatto	Tablero / Plywood / Planche / Sperrholz / Tavola
H30	1	4x4x35	Tilo / Lime wood / Tilleul / Linde / Tiglio
H31	2	Preformado / Preformed/ Préformé / Vorgeformt / Preformato	Latón / Brass / Latón / Messing / Ottone
H32	1	ø0,50x23	Latón / Brass / Latón / Messing / Ottone
H33	2	Preformado / Preformed/ Préformé / Vorgeformt / Preformato	Metal / Metal / Metal / Metall / Metallo
H34	2	4x4x36	Tilo / Lime wood / Tilleul / Linde / Tiglio
H35	1	Precortado / Precut / Prédécoupé / Vorgeschnitten / Pretagliatto	Tablero / Plywood / Planche / Sperrholz / Tavola
H36	4	0,6x5x27	Sicomoro / Sycamore / Sycomore / Bergahorn / Sicomoro
H37	2	2x4x20	Sapelly / Sapelli / Sapelli / Sapelly-Holz / Sapelli
H38	2	2x4x31	Sapelly / Sapelli / Sapelli / Sapelly-Holz / Sapelli
H39	1	Preformado / Preformed/ Préformé / Vorgeformt / Preformato	Metal / Metal / Metal / Metall / Metallo
H40	1	Preformado / Preformed/ Préformé / Vorgeformt / Preformato	Metal / Metal / Metal / Metall / Metallo
H41	1	Preformado / Preformed/ Préformé / Vorgeformt / Preformato	Latón / Brass / Latón / Messing / Ottone
H42	2	Preformado / Preformed/ Préformé / Vorgeformt / Preformato	Metal / Metal / Metal / Metall / Metallo
H43	2	Preformado / Preformed/ Préformé / Vorgeformt / Preformato	Metal / Metal / Metal / Metall / Metallo
H44	2	1x3x20	Tilo / Lime wood / Tilleul / Linde / Tiglio
H45	1	Precortado / Precut / Prédécoupé / Vorgeschnitten / Pretagliatto	Tablero / Plywood / Planche / Sperrholz / Tavola
H46	4	10	Madera / Wood / Bois / Holz
H47	2	4x4x14	Tilo / Lime wood / Tilleul / Linde / Tiglio
H48	1	2x4x30	Sapelly / Sapelli / Sapelli / Sapelly-Holz / Sapelli
i1-i3	5	Precortado / Precut / Prédécoupé / Vorgeschnitten / Pretagliatto	Tablero / Plywood / Planche / Sperrholz / Tavola
i4	22	0,6x5x32	Sicomoro / Sycamore / Sycomore / Bergahorn / Sicomoro
i5	2	1x3x24	Tilo / Lime wood / Tilleul / Linde / Tiglio
i6	2	1x3x28	Tilo / Lime wood / Tilleul / Linde / Tiglio
i7	2	1x5x15	Tilo / Lime wood / Tilleul / Linde / Tiglio
i8	7	2x4x31	Sapelly / Sapelli / Sapelli / Sapelly-Holz / Sapelli
i9	2	Preformado / Preformed/ Préformé / Vorgeformt / Preformato	Latón / Brass / Latón / Messing / Ottone
i10	1	ø1x15	Latón / Brass / Latón / Messing / Ottone
i11	3	ø1x10	Latón / Brass / Latón / Messing / Ottone
i12-i15	6	Precortado / Precut / Prédécoupé / Vorgeschnitten / Pretagliatto	Tablero / Plywood / Planche / Sperrholz / Tavola
i16	20	0,6x5x25	Sicomoro / Sycamore / Sycomore / Bergahorn / Sicomoro
i17	5	0,6x5x26	Sapelly / Sapelli / Sapelli / Sapelly-Holz / Sapelli
i18	2	2x2x20	Tilo / Lime wood / Tilleul / Linde / Tiglio
i19	2	2x2x26	Tilo / Lime wood / Tilleul / Linde / Tiglio
i20	2	1x3x20	Tilo / Lime wood / Tilleul / Linde / Tiglio
i21	2	1x3x24	Tilo / Lime wood / Tilleul / Linde / Tiglio
i22	2	1x5x15	Tilo / Lime wood / Tilleul / Linde / Tiglio
i23	4	ø1x3	Latón / Brass / Latón / Messing / Ottone
i24	1	4x4x25	Tilo / Lime wood / Tilleul / Linde / Tiglio
i25	1	ø1x15	Latón / Brass / Latón / Messing / Ottone
i26	2	Preformado / Preformed/ Préformé / Vorgeformt / Preformato	Latón / Brass / Latón / Messing / Ottone
i27	1	Preformado / Preformed/ Préformé / Vorgeformt / Preformato	Metal / Metal / Metal / Metall / Metallo
i28	2	Precortado / Precut / Prédécoupé / Vorgeschnitten / Pretagliatto	Tablero / Plywood / Planche / Sperrholz / Tavola
i29	1	ø1x15	Latón / Brass / Latón / Messing / Ottone
i30	1	Preformado / Preformed/ Préformé / Vorgeformt / Preformato	Madera / Wood / Bois / Holz
i31	1	Preformado / Preformed/ Préformé / Vorgeformt / Preformato	Latón / Brass / Latón / Messing / Ottone
i32	2	ø0,15x400	Hilo algodón crudo / Raw cotton thread / Fil coton brut / Rohes Baumwollfaden
i33	2	4x4x12	Tilo / Lime wood / Tilleul / Linde / Tiglio
i34	2	4x4x22	Tilo / Lime wood / Tilleul / Linde / Tiglio
i35	2	2x5x12	Tilo / Lime wood / Tilleul / Linde / Tiglio
i36-i37	2	Preformado / Preformed/ Préformé / Vorgeformt / Preformato	Latón / Brass / Latón / Messing / Ottone
i38	4	ø1,5x75	Latón / Brass / Latón / Messing / Ottone
i39	2	Precortado / Precut / Prédécoupé / Vorgeschnitten / Pretagliatto	Tablero / Plywood / Planche / Sperrholz / Tavola
i40	2	2x2x49	Tilo / Lime wood / Tilleul / Linde / Tiglio
i41	2	Precortado / Precut / Prédécoupé / Vorgeschnitten / Pretagliatto	Tablero / Plywood / Planche / Sperrholz / Tavola
i42	2	2x2x52	Tilo / Lime wood / Tilleul / Linde / Tiglio
i43	2	Precortado / Precut / Prédécoupé / Vorgeschnitten / Pretagliatto	Tablero / Plywood / Planche / Sperrholz / Tavola
i44	2	2x2x40	Tilo / Lime wood / Tilleul / Linde / Tiglio
i45	2	2x5x36	Tilo / Lime wood / Tilleul / Linde / Tiglio
J1	37	2x3x8	Tilo / Lime wood / Tilleul / Linde / Tiglio
J2	2	2x3x30	Tilo / Lime wood / Tilleul / Linde / Tiglio
J3	6	3x3x50	Tilo / Lime wood / Tilleul / Linde / Tiglio
J4	6	3x3x22	Tilo / Lime wood / Tilleul / Linde / Tiglio
J5	6	3x3x20	Tilo / Lime wood / Tilleul / Linde / Tiglio
J6	6	3x3x65	Tilo / Lime wood / Tilleul / Linde / Tiglio
J7	6	3x3x20	Tilo / Lime wood / Tilleul / Linde / Tiglio
J8	6	Precortado / Precut / Prédécoupé / Vorgeschnitten / Pretagliatto	Tablero / Plywood / Planche / Sperrholz / Tavola
J9	1	3x3x102	Tilo / Lime wood / Tilleul / Linde / Tiglio
J10	1	3x3x106	Tilo / Lime wood / Tilleul / Linde / Tiglio

**Lista de piezas / Parts List / Liste des pièces / Teileliste / Elenco delle parti**

<b>Nº/No./ Nº / Nr. No</b>	<b>Cantidad / Quantity / Quantité / Menge / Quantità</b>	<b>Medidas / Measurements / Dimensions / Maße / Misure</b>	<b>Material / Material / Matériau / Material / Materiale</b>
J11	4	3x3x38	Tilo / Lime wood / Tilleul / Linde / Tiglio
J12	44	ø0,50x125	Hilo algodón marrón / Brown cotton thread / Fil coton brun /braunes Baumwollfaden
J13	2	Preformado / Preformed/ Préformé / Vorgeformt / Preformato	Metal / Metal / Metal / Metall / Metallo
J14	4	3x3x40	Tilo / Lime wood / Tilleul / Linde / Tiglio
J15	2	ø6	Latón / Brass / Latón / Messing / Ottone
J16	2	ø1.5x200	Hilo algodón marrón / Brown cotton thread / Fil coton brun /braunes Baumwollfaden
J17	2	ø0,15x100	Hilo algodón crudo / Raw cotton thread / Fil coton brut / Rohes Baumwollfaden
J18	2	1x150	Latón / Brass / Latón / Messing / Ottone
J19	2	ø0,15x150	Hilo algodón crudo / Raw cotton thread / Fil coton brut / Rohes Baumwollfaden
J20	2	ø0,15x250	Hilo algodón crudo / Raw cotton thread / Fil coton brut / Rohes Baumwollfaden
J21	2	ø1.5x250	Hilo algodón marrón / Brown cotton thread / Fil coton brun /braunes Baumwollfaden
K-1	4	Precortado / Precut / Prédécoupé / Vorgeschnitten / Pretagliato	Tablero / Plywood / Planche / Sperrholz / Tavola
K2-K12	44	Precortado / Precut / Prédécoupé / Vorgeschnitten / Pretagliato	Tablero / Plywood / Planche / Sperrholz / Tavola
K13	8	Precortado / Precut / Prédécoupé / Vorgeschnitten / Pretagliato	Tablero / Plywood / Planche / Sperrholz / Tavola
K14	8	Precortado / Precut / Prédécoupé / Vorgeschnitten / Pretagliato	Tablero / Plywood / Planche / Sperrholz / Tavola
K15	4	Precortado / Precut / Prédécoupé / Vorgeschnitten / Pretagliato	Tablero / Plywood / Planche / Sperrholz / Tavola
K16	60	1x3x150	Tilo / Lime wood / Tilleul / Linde / Tiglio / Ramin /
K17	12	1x3x90	Tilo / Lime wood / Tilleul / Linde / Tiglio / Ramin /
K18	4	Precortado / Precut / Prédécoupé / Vorgeschnitten / Pretagliato	Tablero / Plywood / Planche / Sperrholz / Tavola
K19	4	Precortado / Precut / Prédécoupé / Vorgeschnitten / Pretagliato	Tablero / Plywood / Planche / Sperrholz / Tavola
K20	4	2x2x88	Tilo / Lime wood / Tilleul / Linde / Tiglio / Ramin /
K21	4	Precortado / Precut / Prédécoupé / Vorgeschnitten / Pretagliato	Tablero / Plywood / Planche / Sperrholz / Tavola
K22	20	1x3x28	Tilo / Lime wood / Tilleul / Linde / Tiglio / Ramin /
K23	24	1x3x6	Tilo / Lime wood / Tilleul / Linde / Tiglio / Ramin /
K24	8	2x3x22	Tilo / Lime wood / Tilleul / Linde / Tiglio / Ramin /
K25	4	2x3x18	Tilo / Lime wood / Tilleul / Linde / Tiglio / Ramin /
K26	4	Precortado / Precut / Prédécoupé / Vorgeschnitten / Pretagliato	Tablero / Plywood / Planche / Sperrholz / Tavola
K27	4	ø1x20	Latón / Brass / Latón / Messing / Ottone
K28	1	ø0,15x200	Hilo algodón crudo / Raw cotton thread / Fil coton brut / Rohes Baumwollfaden
K29	6	ø0,15x250	Hilo algodón crudo / Raw cotton thread / Fil coton brut / Rohes Baumwollfaden
X-Y	2	Precortado / Precut / Prédécoupé / Vorgeschnitten / Pretagliato	Tablero / Plywood / Planche / Sperrholz / Tavola
Z	2	Precortado / Precut / Prédécoupé / Vorgeschnitten / Pretagliato	Tablero / Plywood / Planche / Sperrholz / Tavola

**Lista de piezas / Parts List / Liste des pièces / Teileliste / Elenco delle parti**

<b>Nº/No./ Nº / Nr. No</b>	<b>Descripción / Description / Description / Beschreibung / Descrizione</b>	<b>Cantidad / Quantity / Quantité / Menge / Quantità</b>	<b>Medidas / Measurements / Dimensions / Maße / Misure</b>	<b>Material / Material / Matériau / Material / Materiale</b>
A		700	10	Metal / Metal / Metal / Metall / Metallo
B		125	10	Latón / Brass / Latón / Messing / Ottone
C		155	ø0,15x100	Hilo crudo / Raw thread / Fil brut / Rohes Baumwollfaden / Filo crudo
D		105	4	Composite / Composite / Composite / Composite / Composite
E		50	4	Composite / Composite / Composite / Composite / Composite
F		55	ø5	Composite / Composite / Composite / Composite / Composite
G		85	ø4	Composite / Composite / Composite / Composite / Composite
H		25	3	Latón / Brass / Laiton / Messing / Ottone
I		6	10	Latón / Brass / Laiton / Messing / Ottone
J		90	10	Composite / Composite / Composite / Composite / Composite

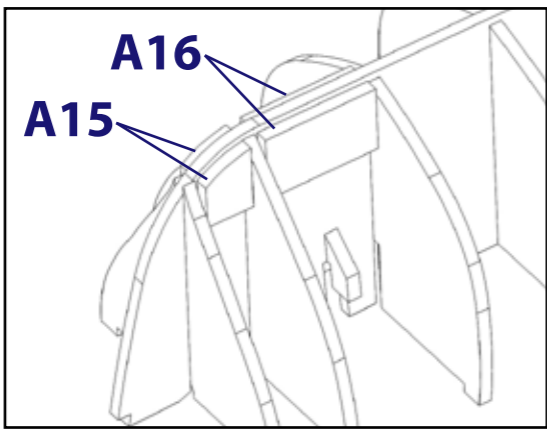

Accede a vídeos tutoriales fotografiando los códigos QR.  
Access tutorial videos photographing QR codes.  
Accédez aux didacticiels vidéo photographiant les codes QR.  
Greifen Sie auf Video-Tutorials zu, die QR-Code fotografieren.  
Accedi ai video tutorial fotografando i codici QR.  
Доступ к видеоурокам фотографирования QR-кодов.

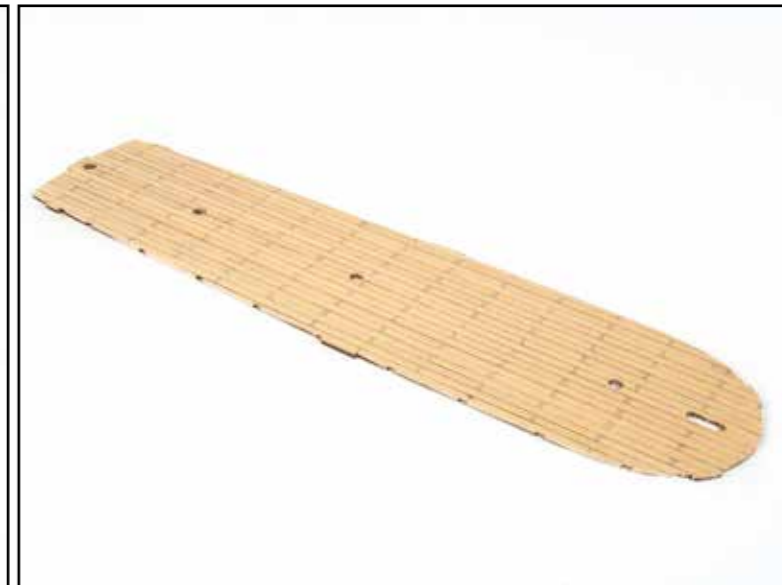
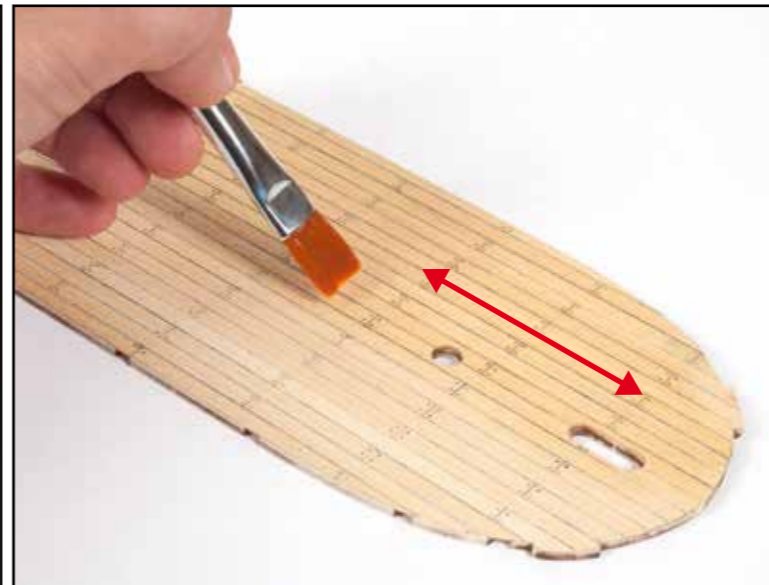
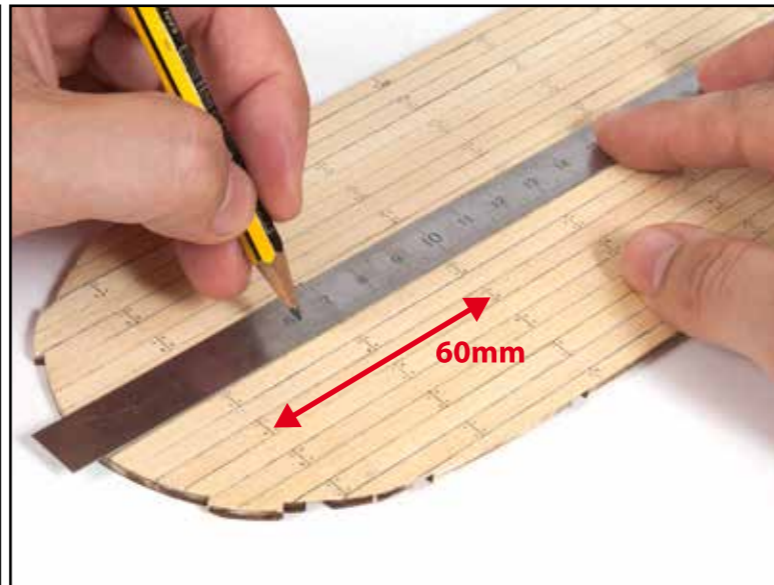
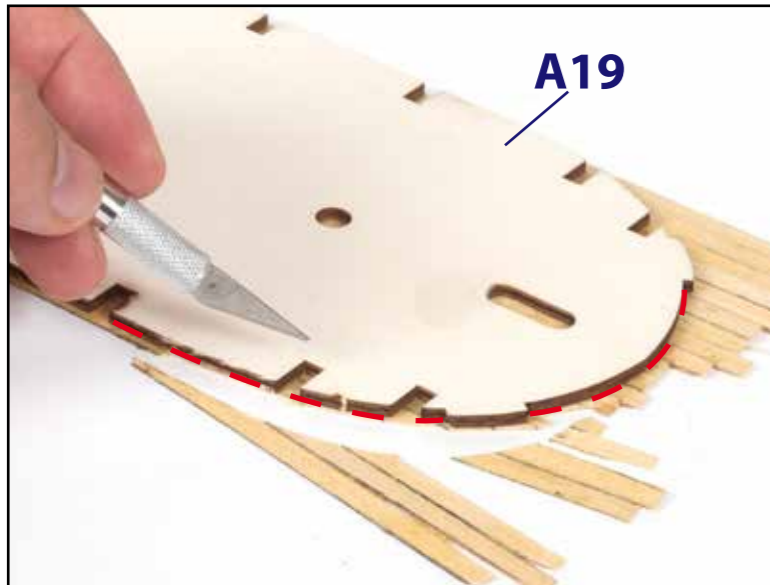
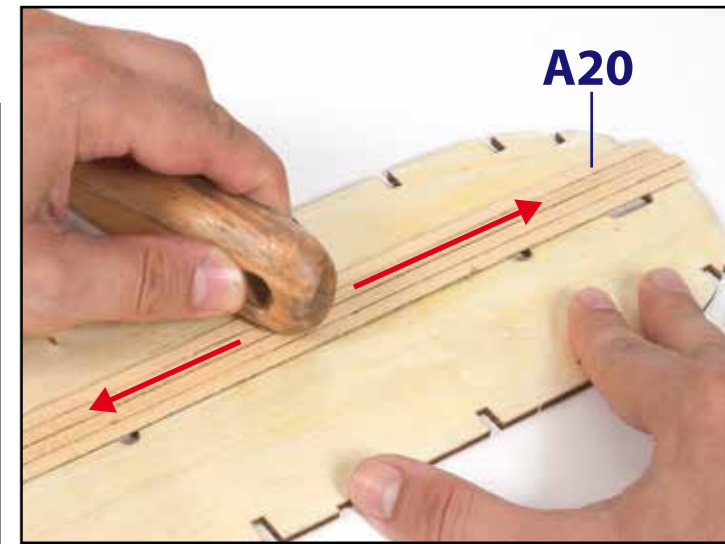
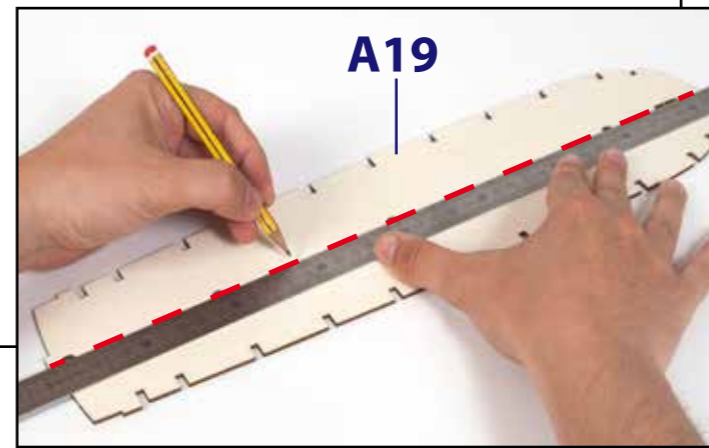
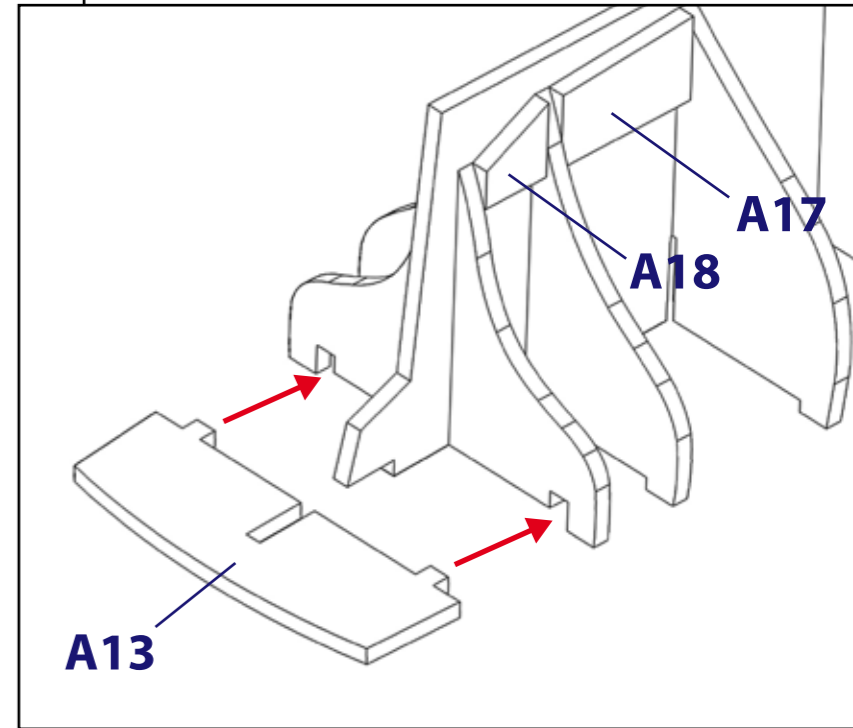
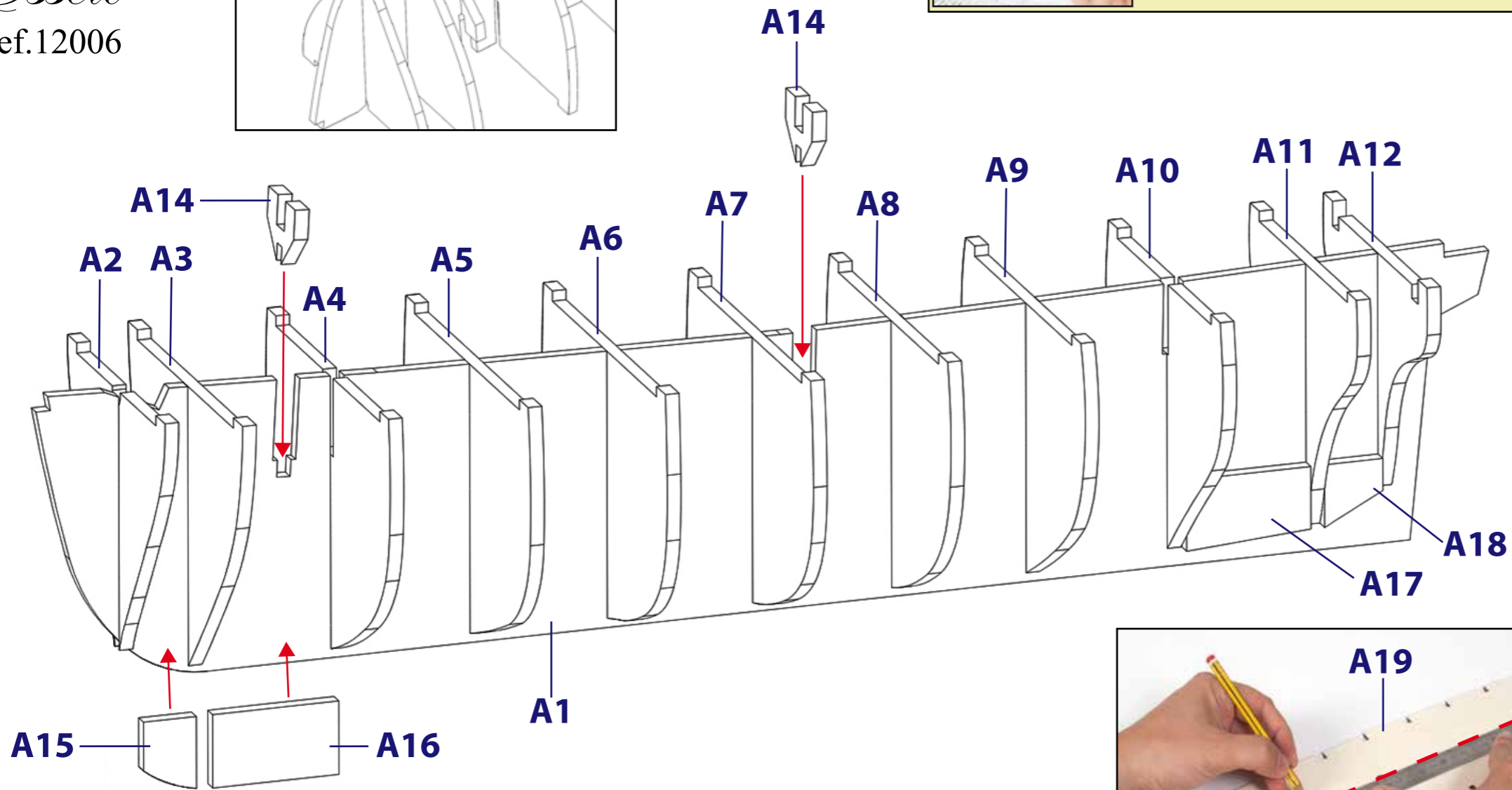

**B**

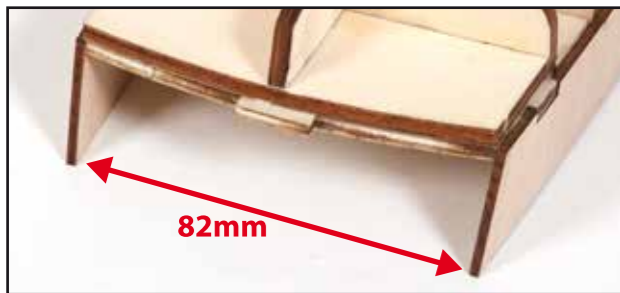
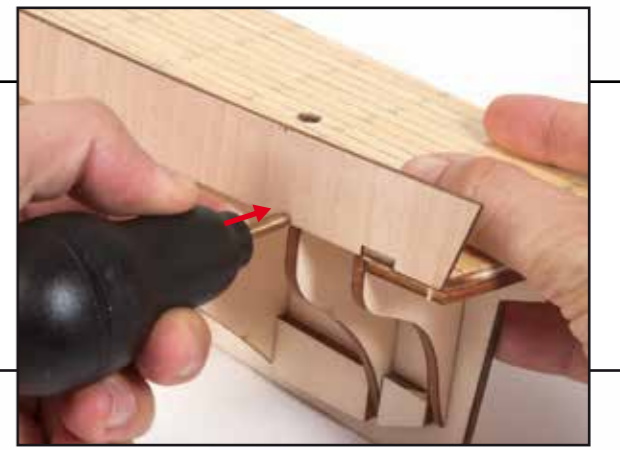
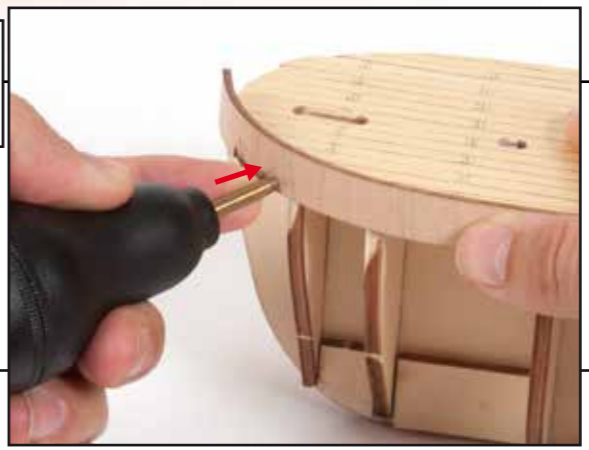
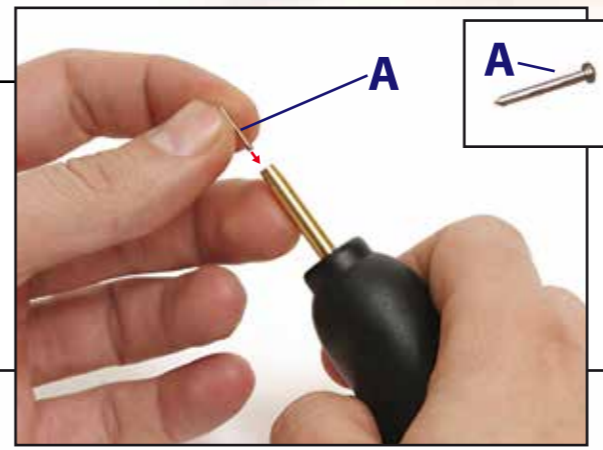
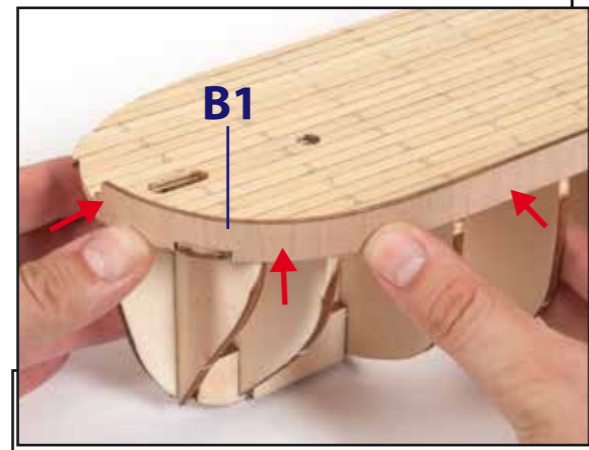
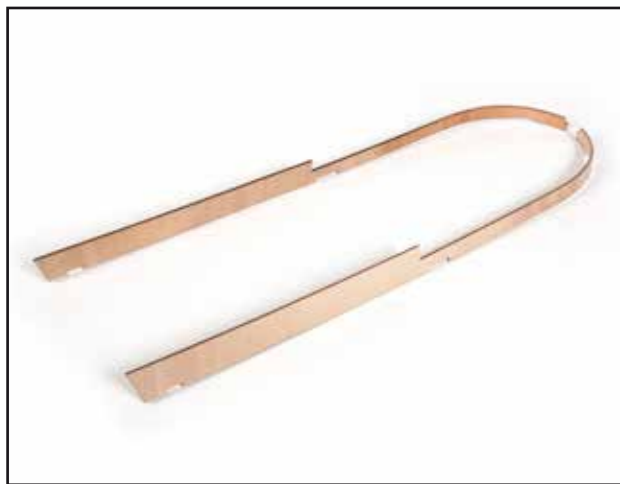
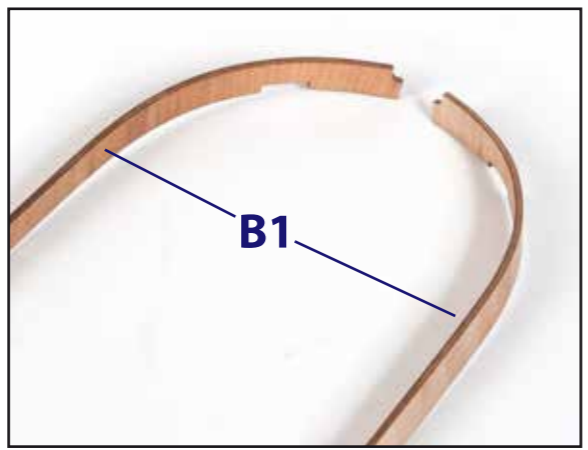
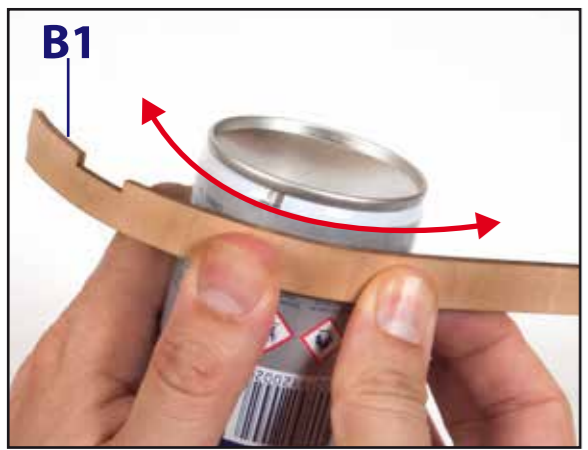
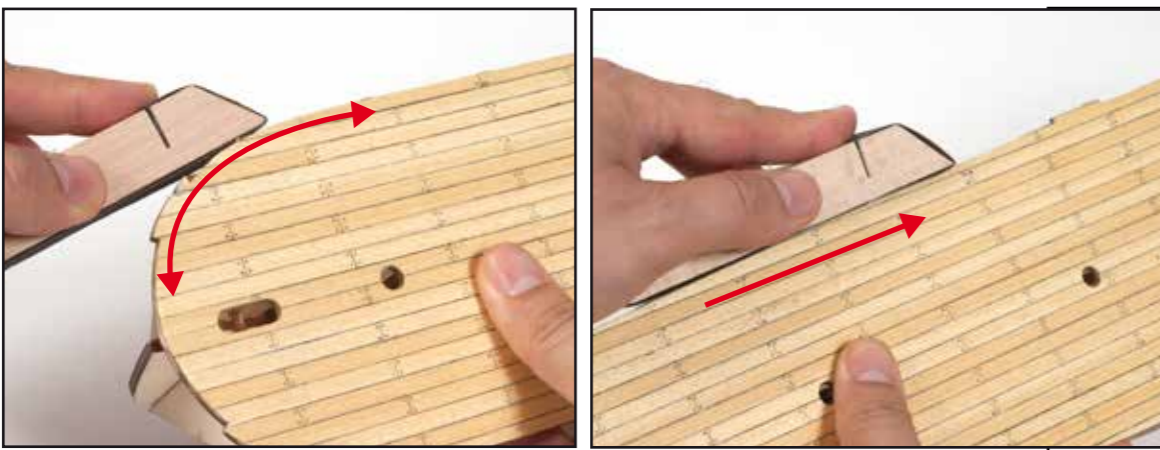

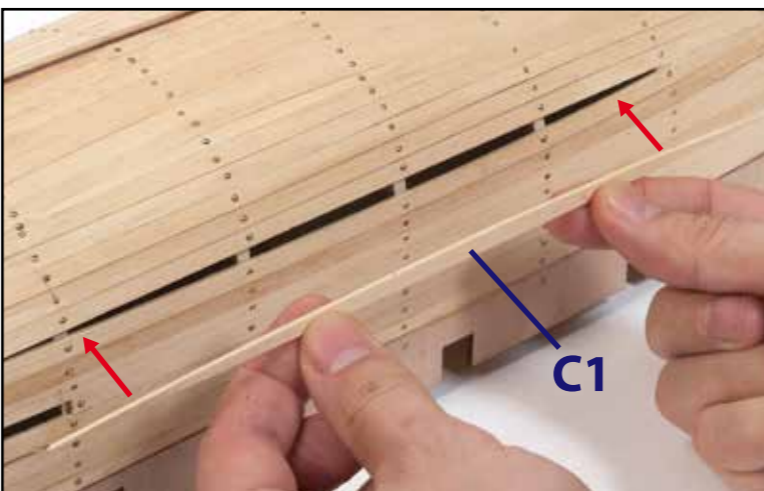
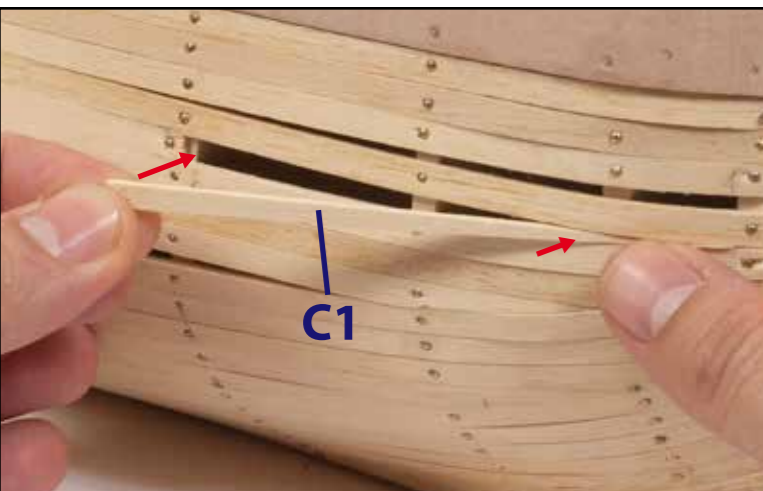
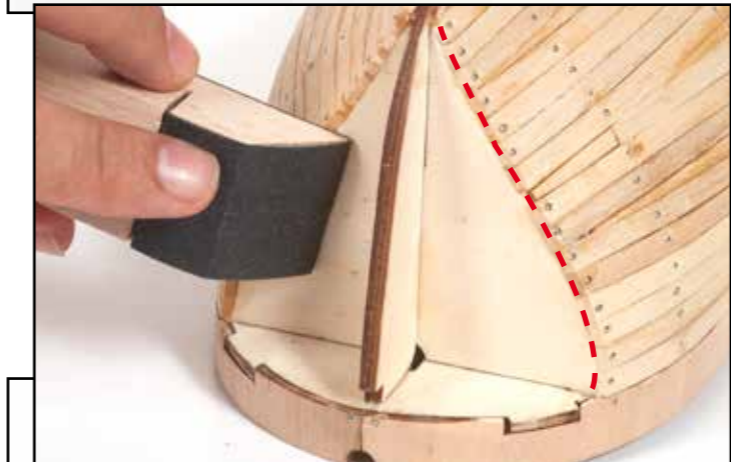
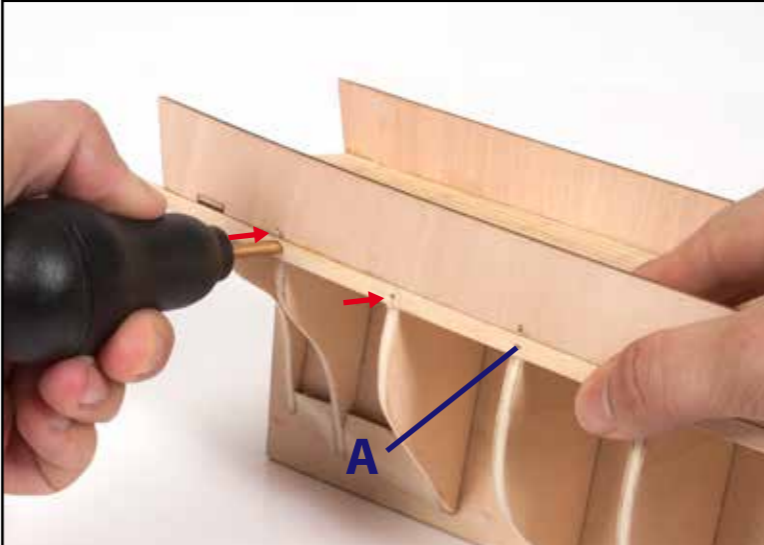
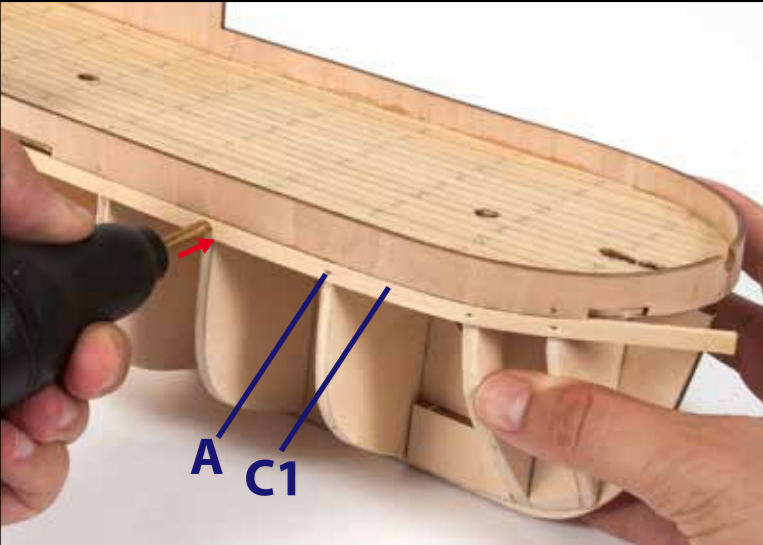
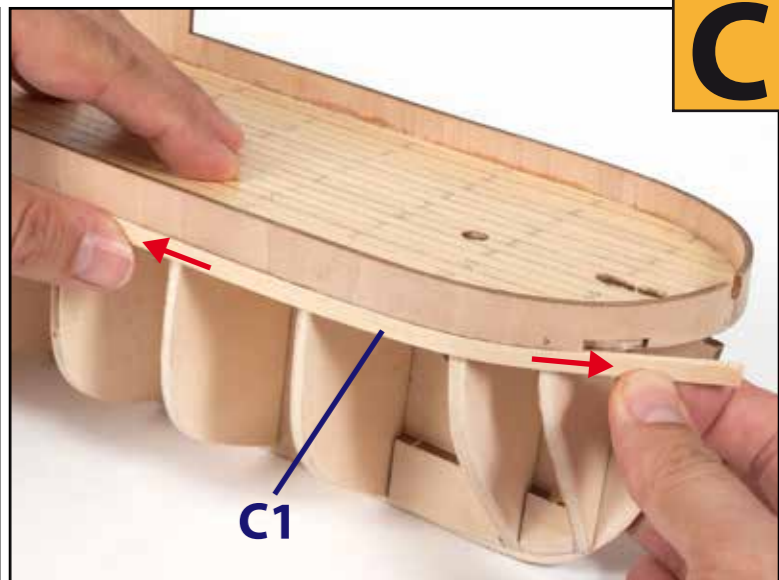
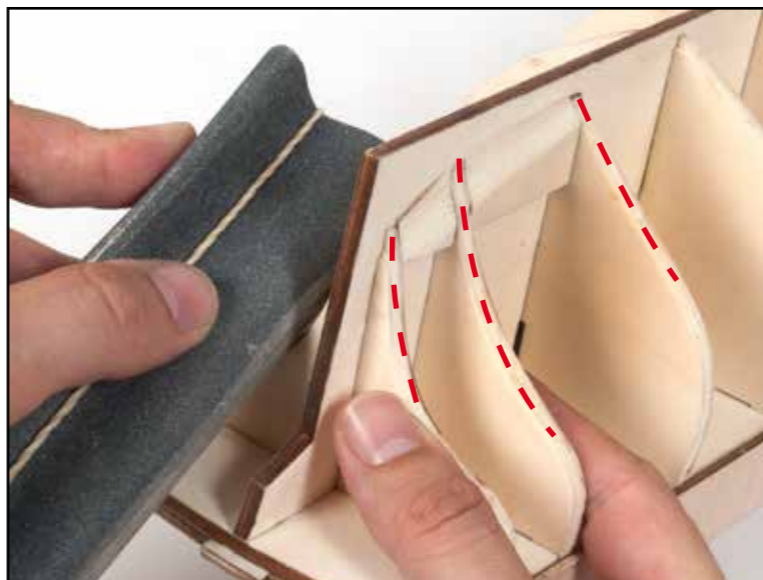
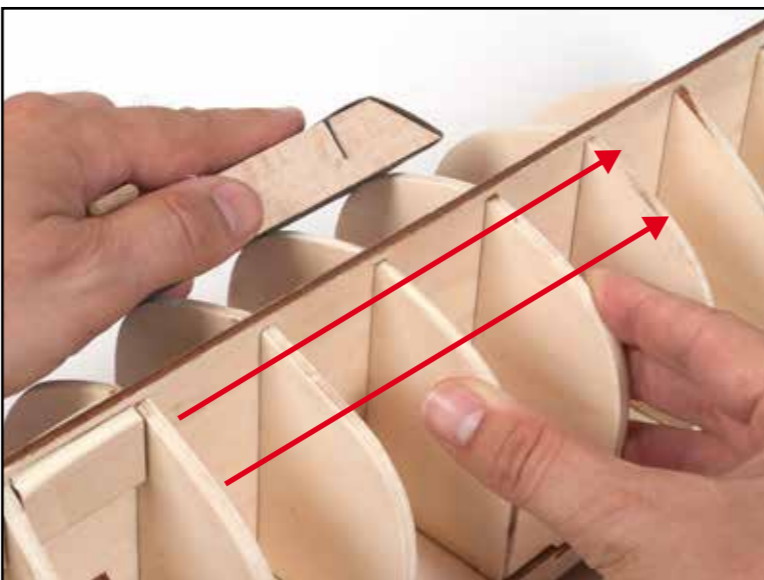
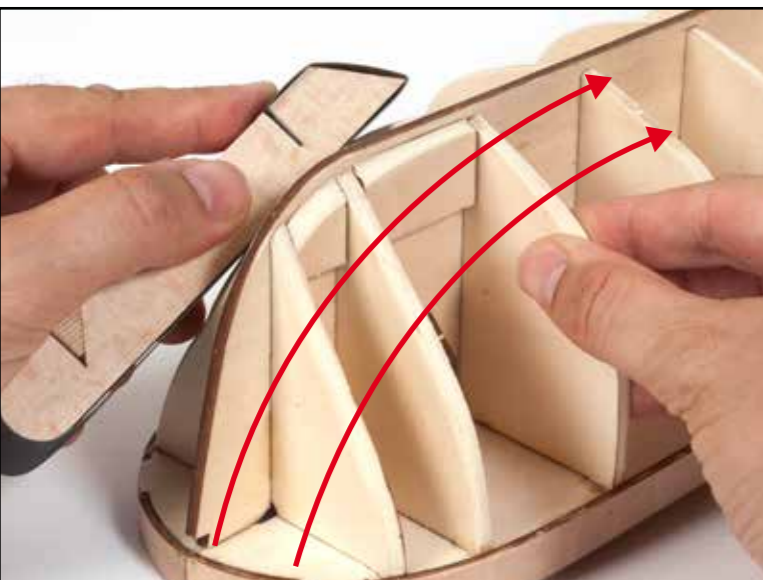

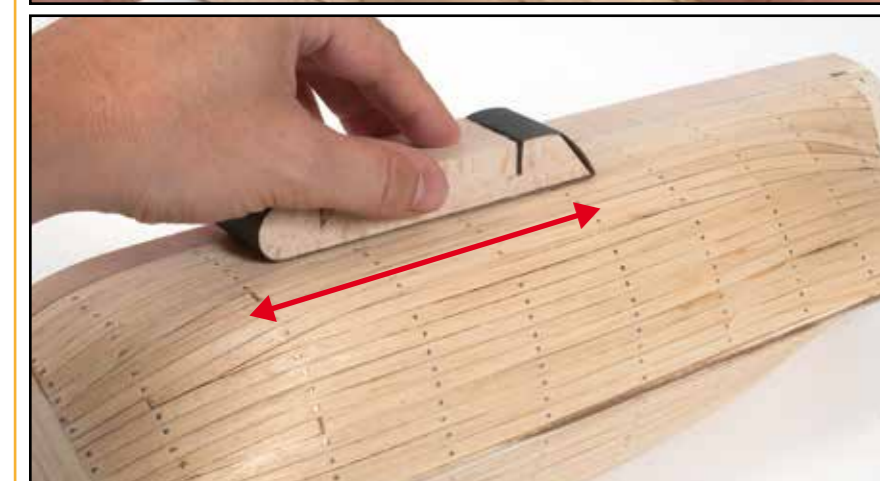
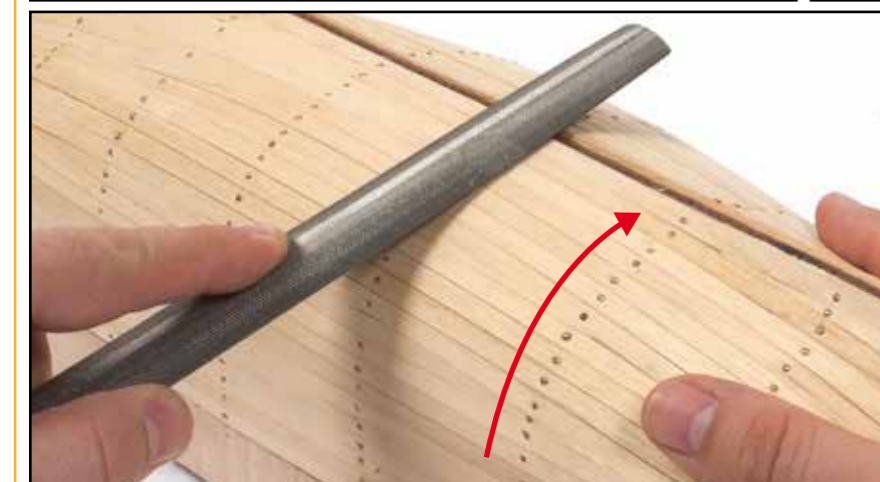
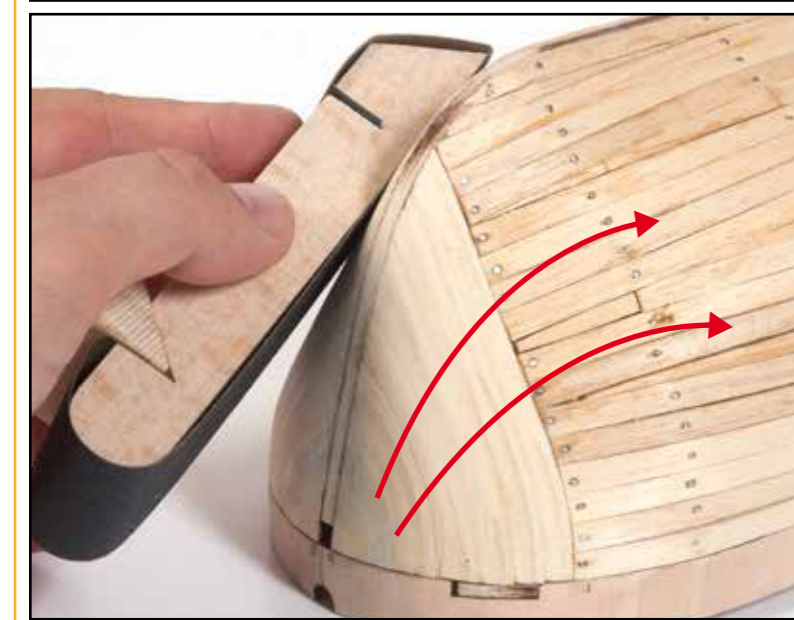
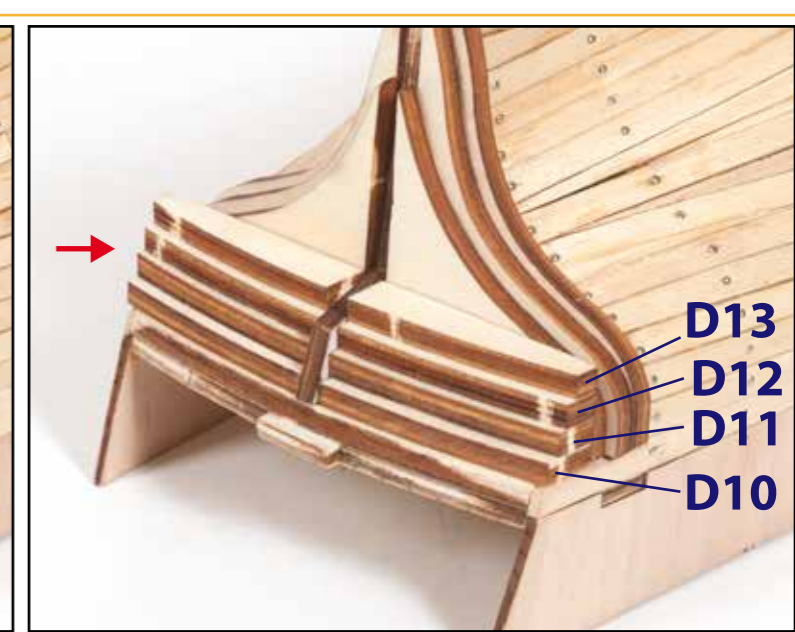
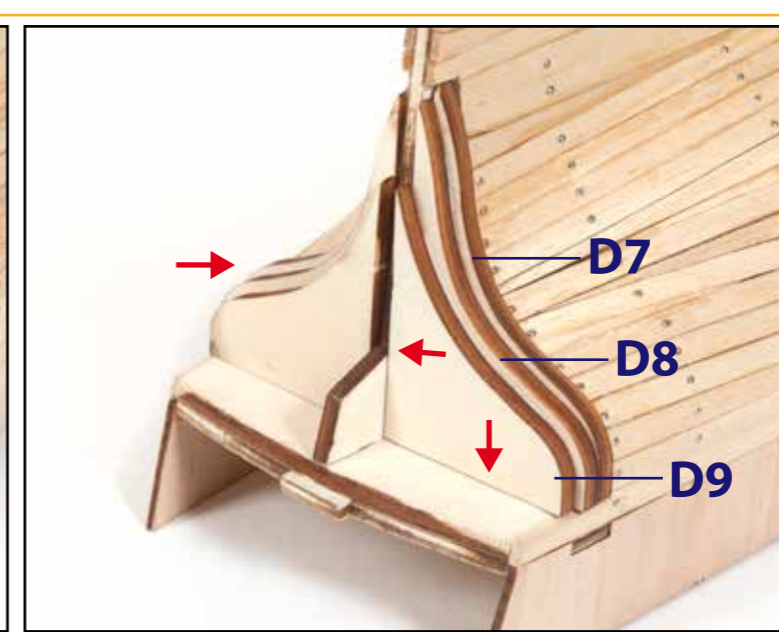
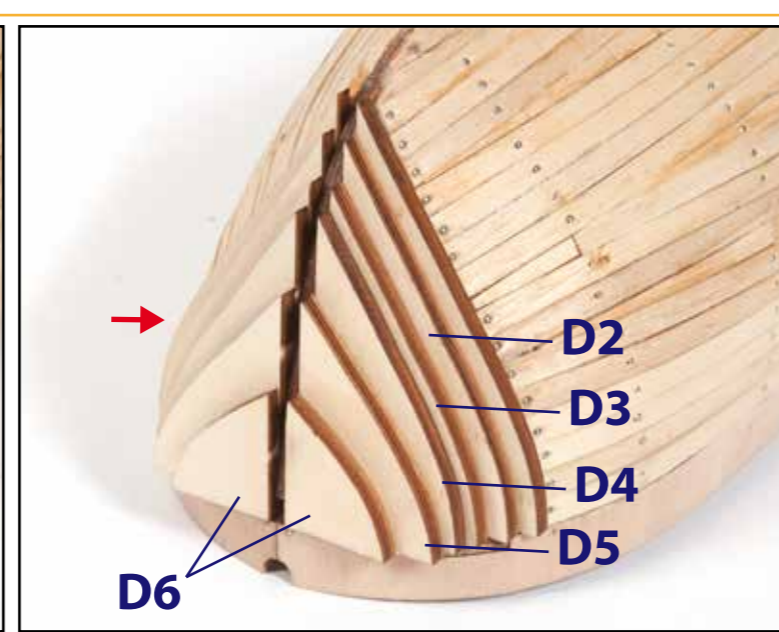
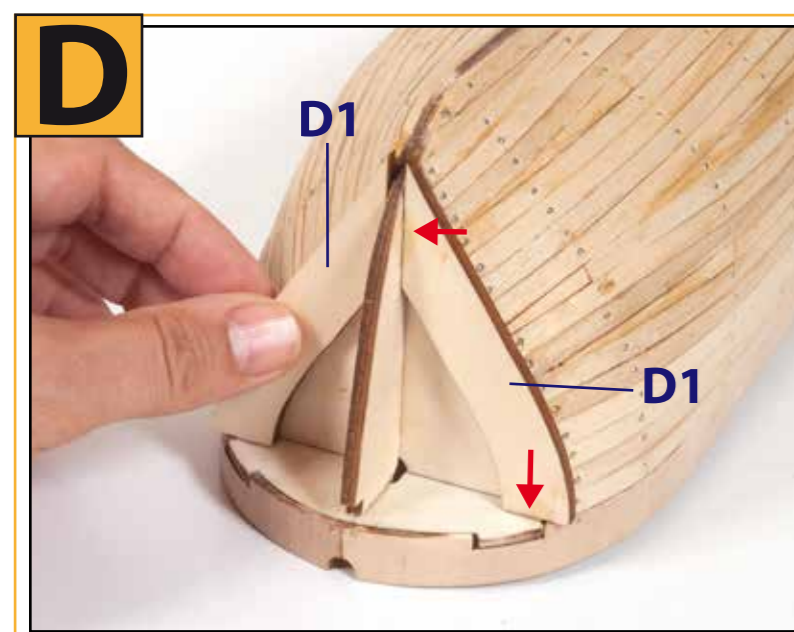
**D**

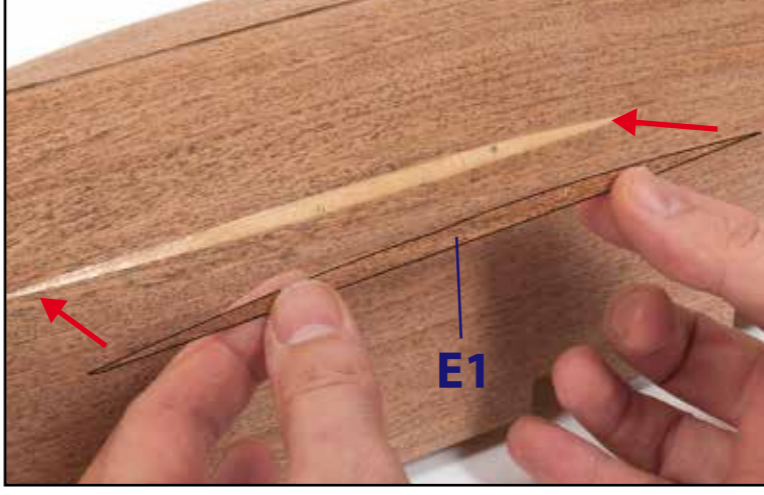
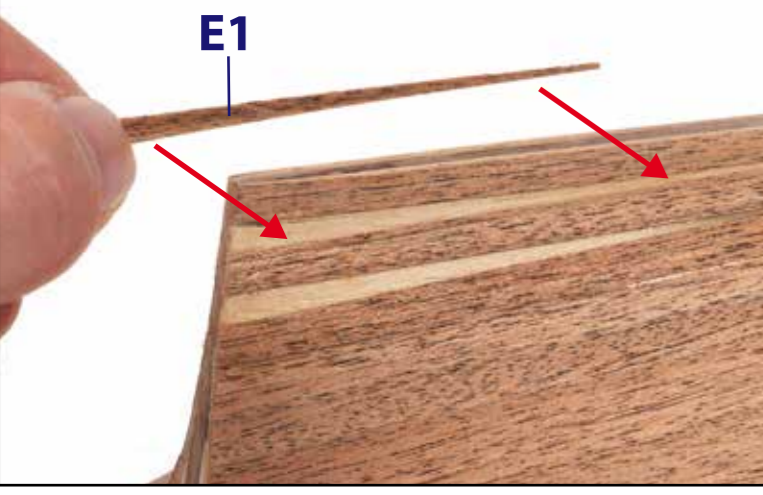
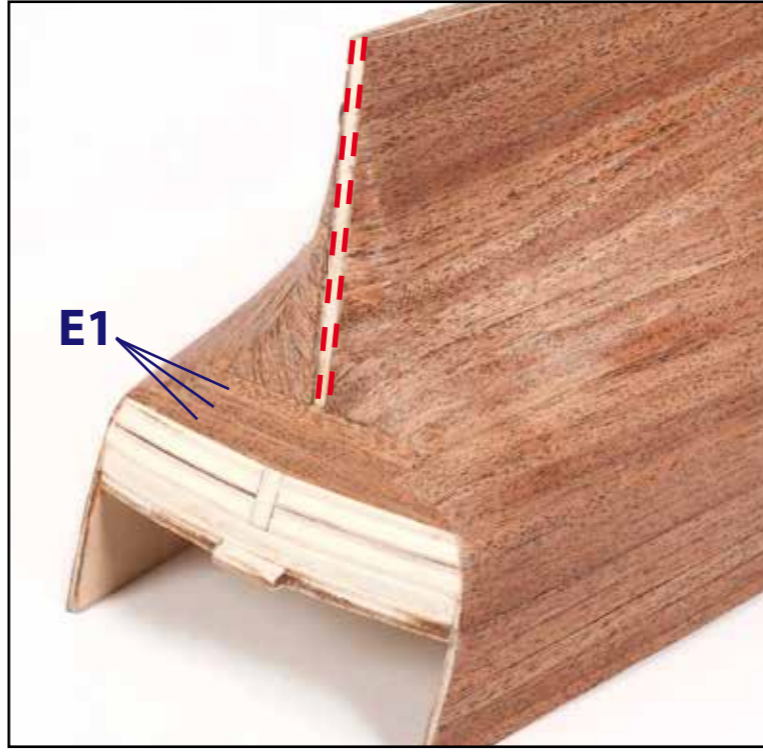
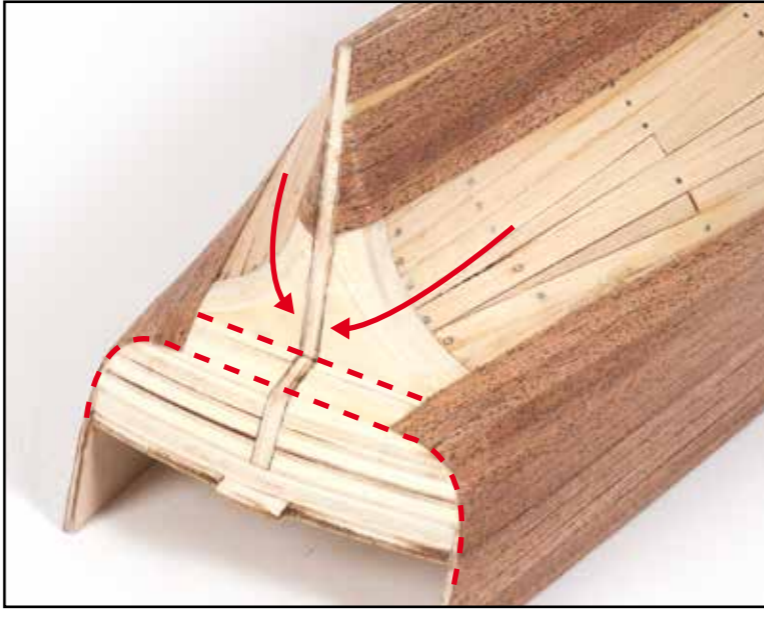
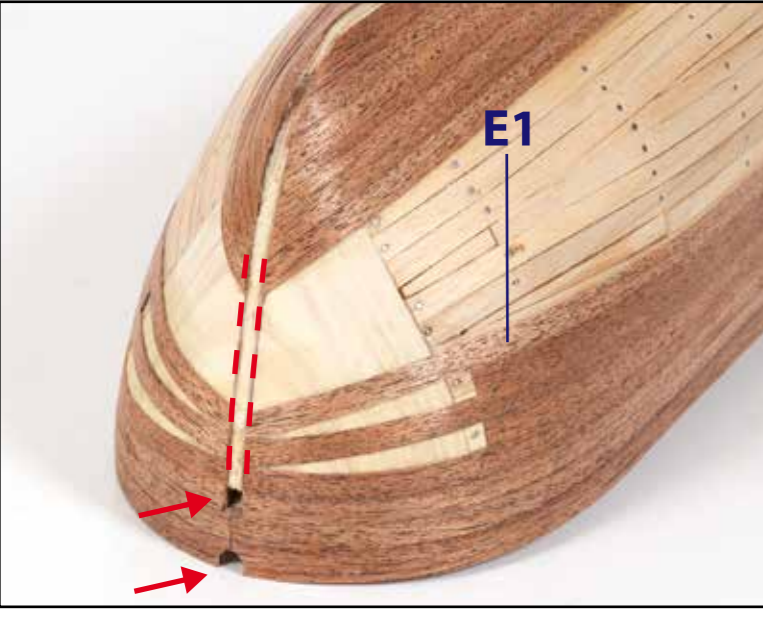
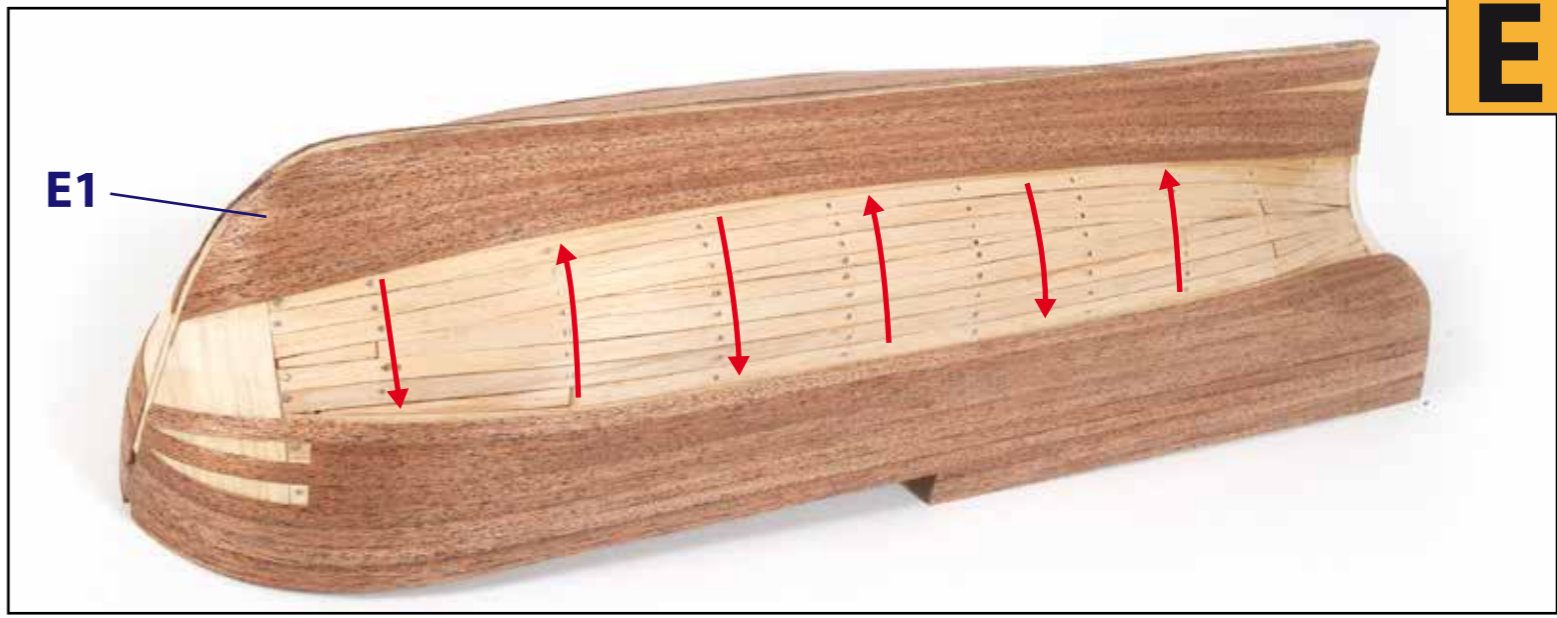
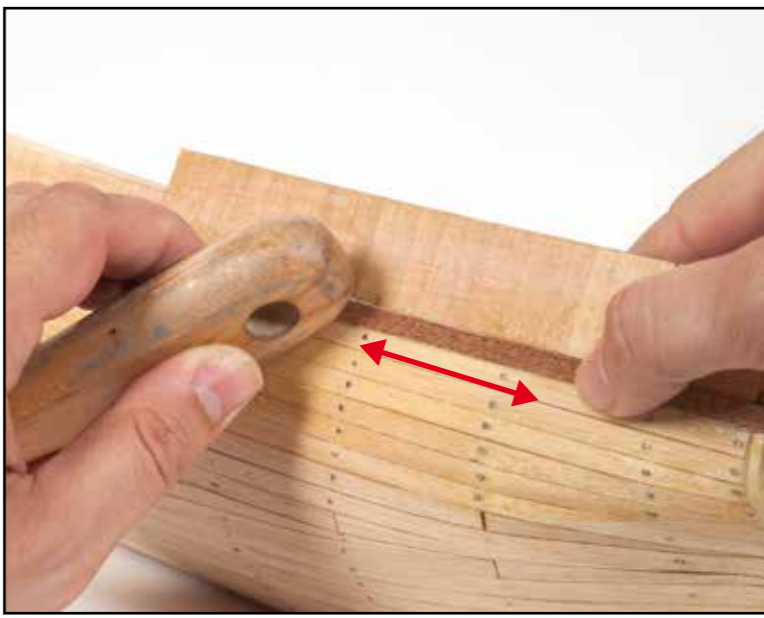
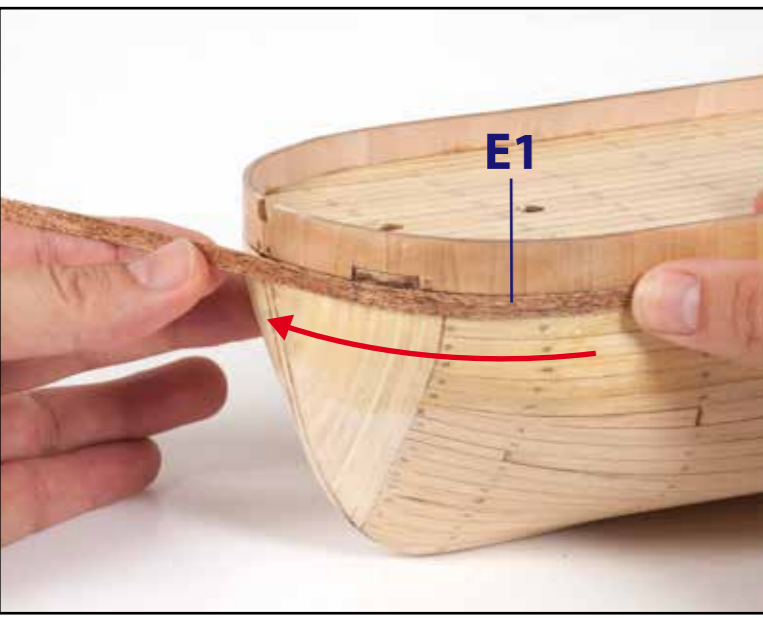

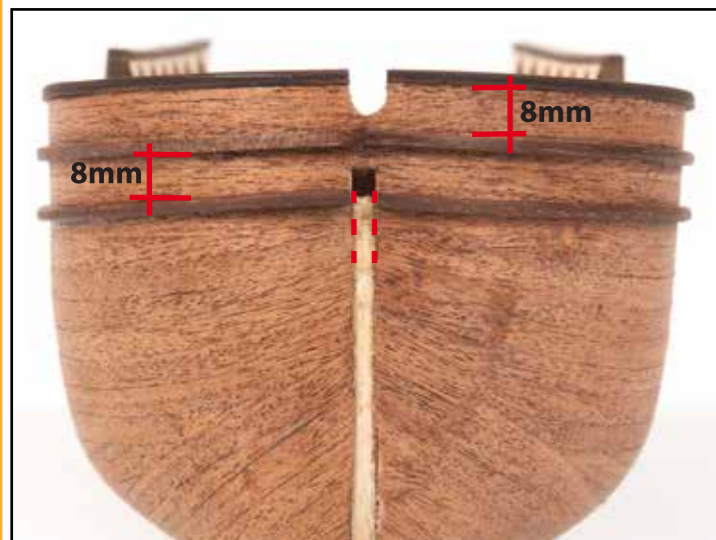
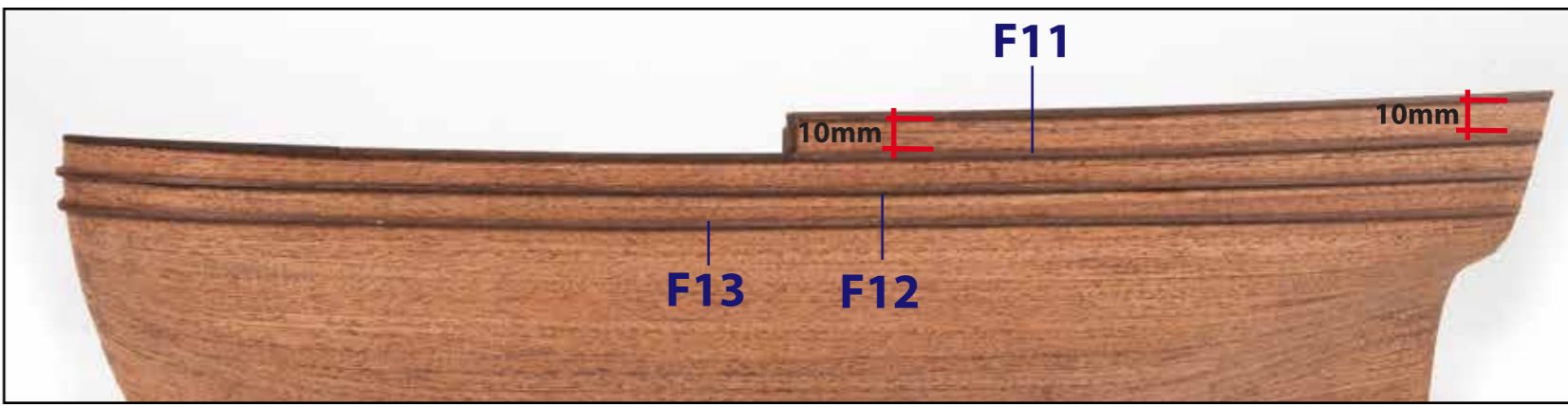
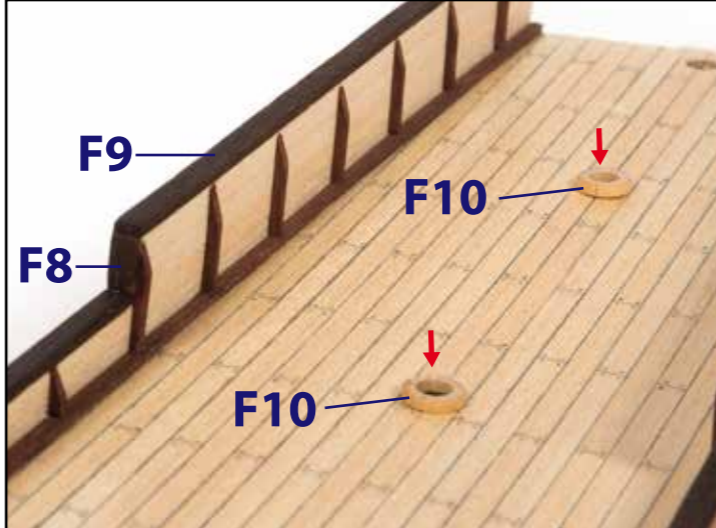
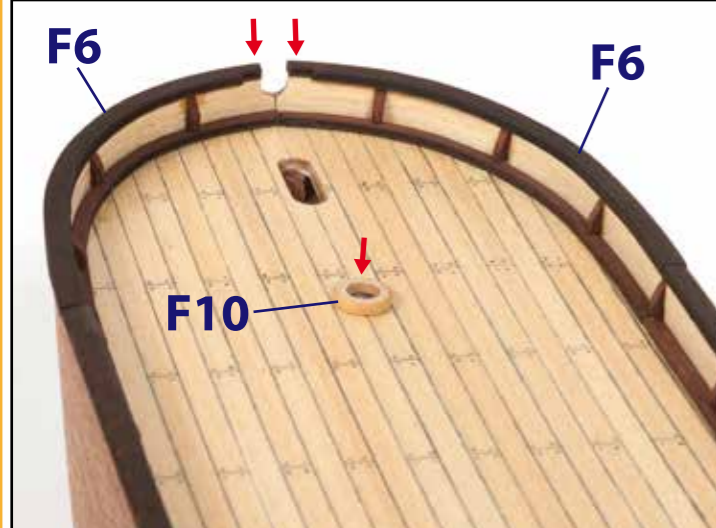
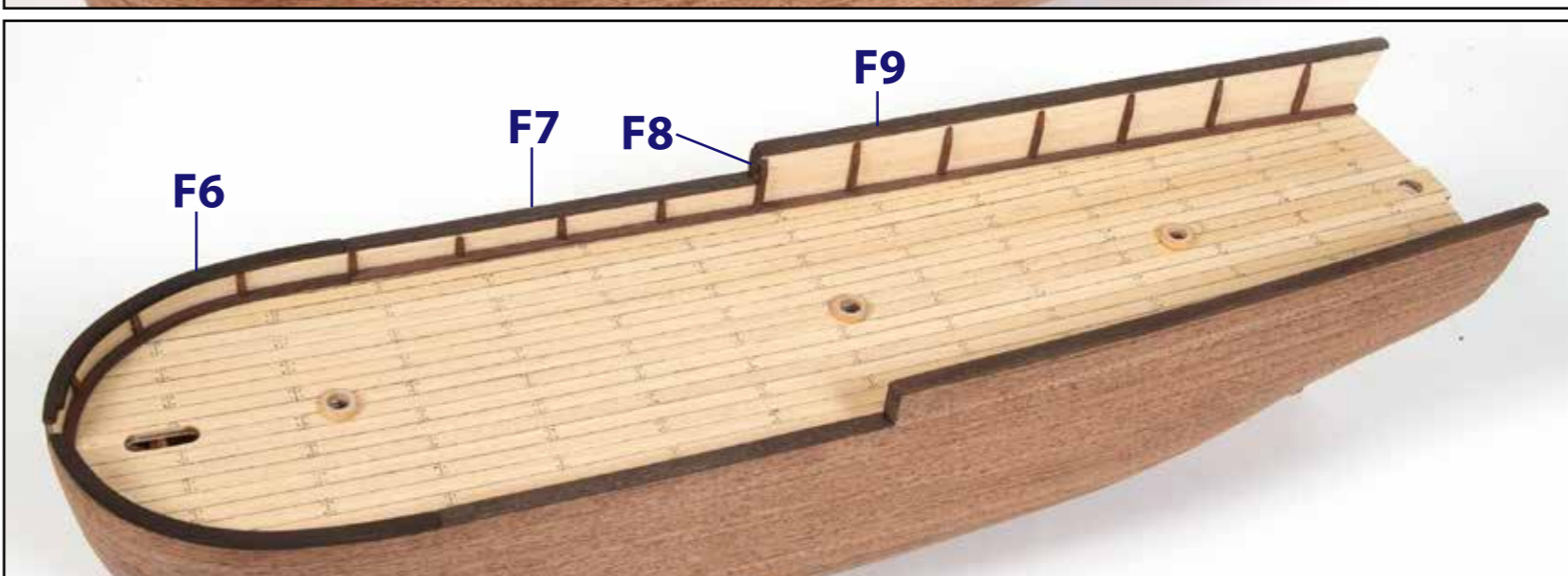
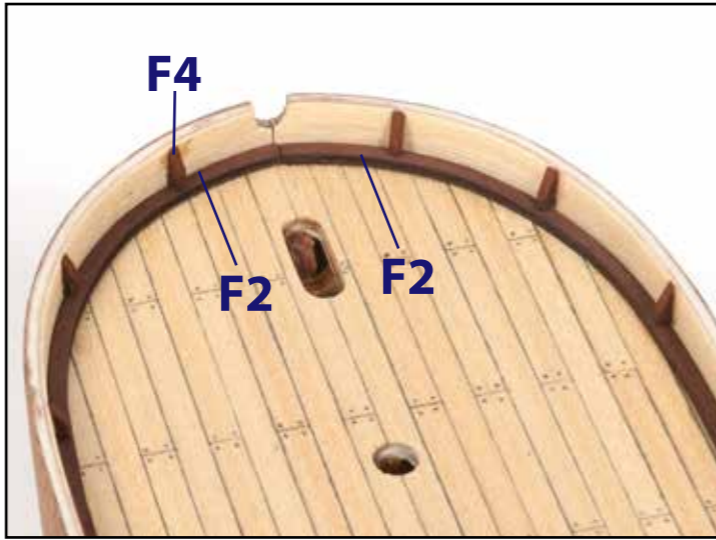
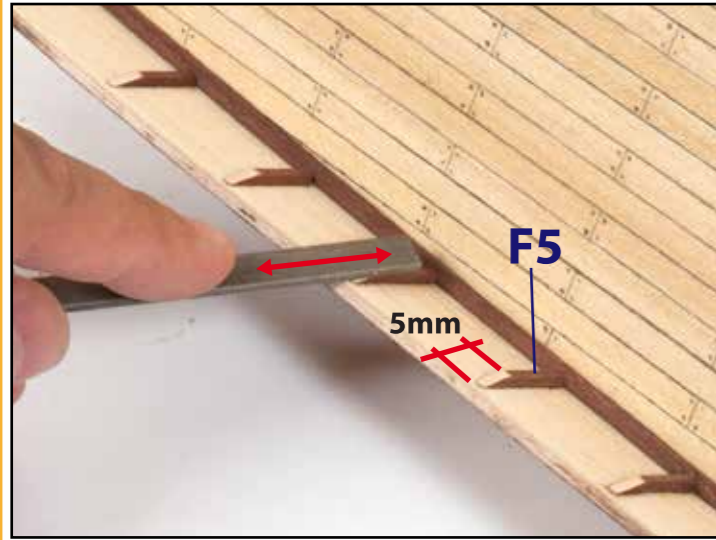
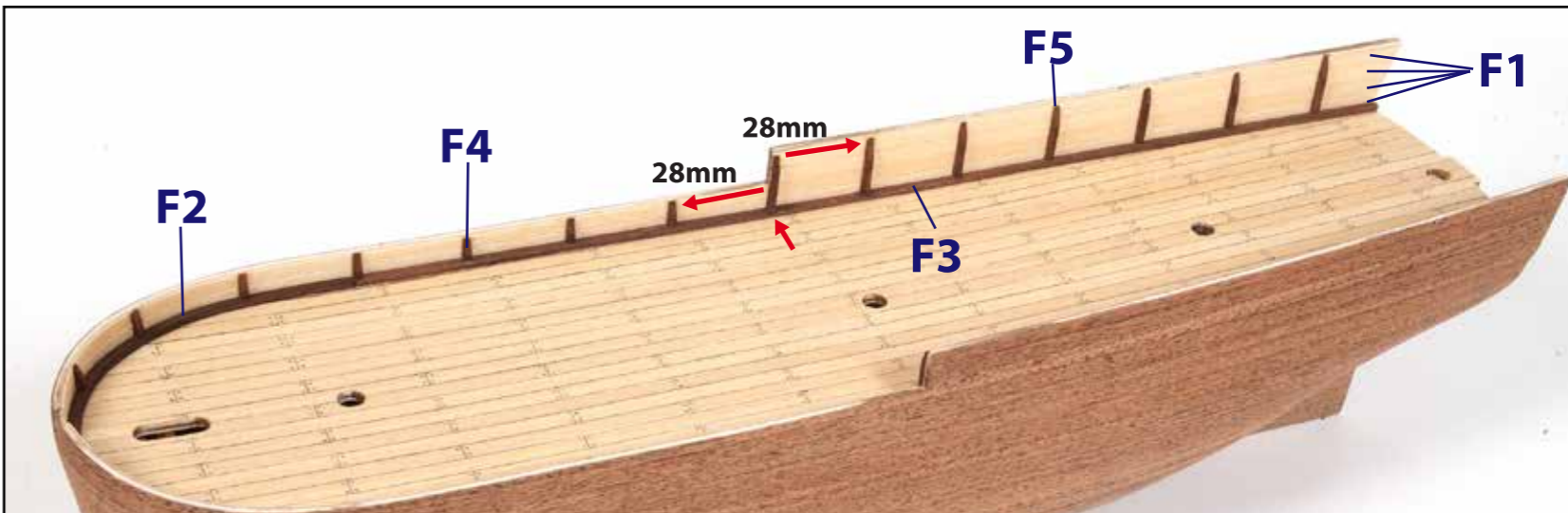
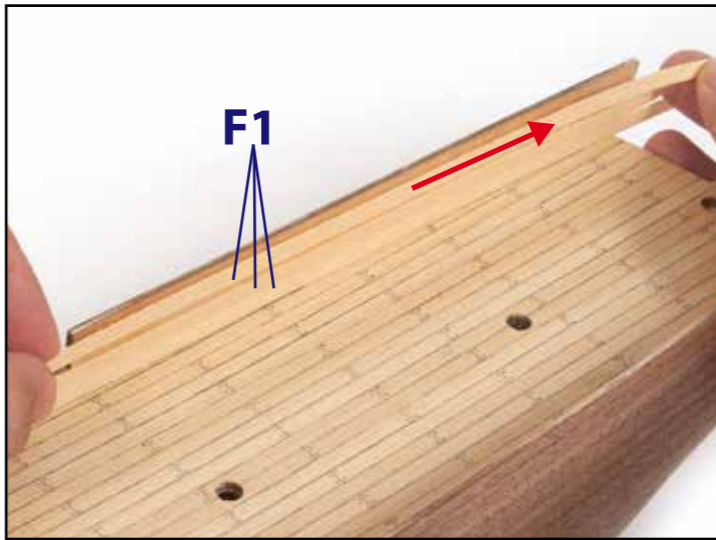
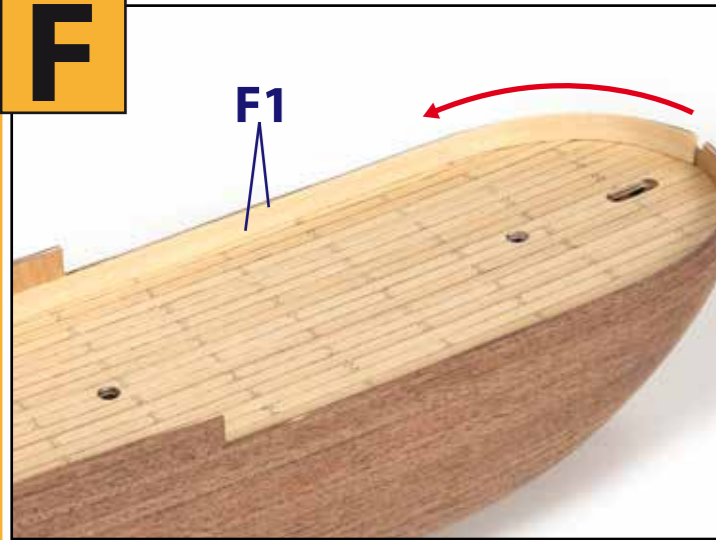
**F**



**G**

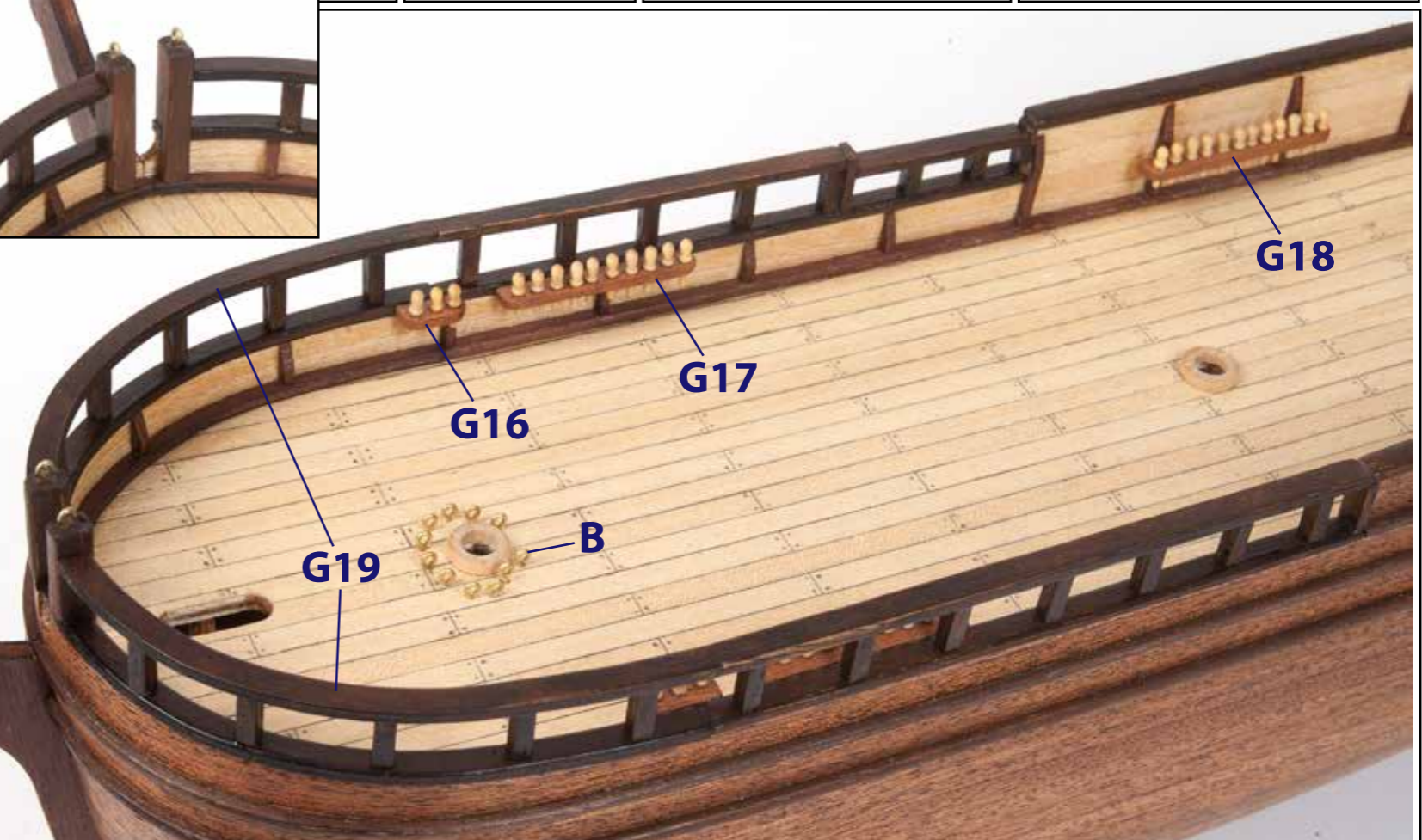
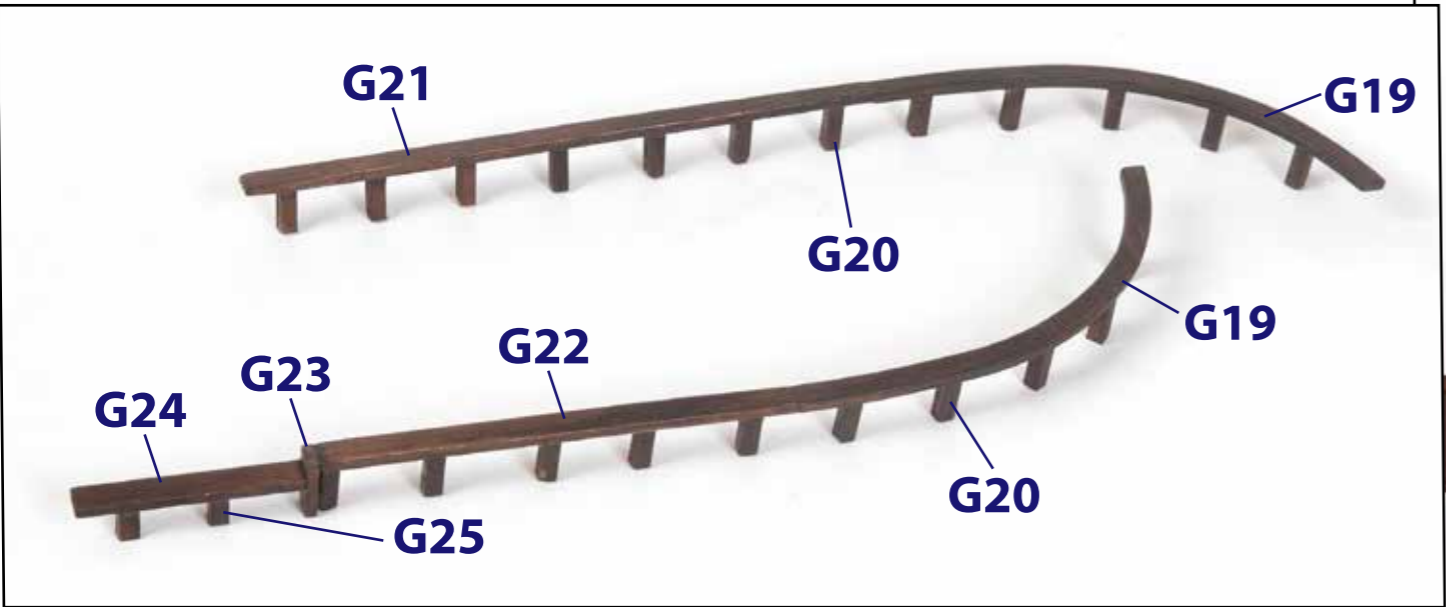
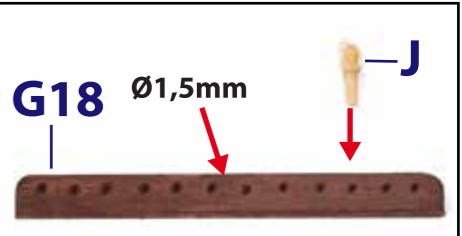
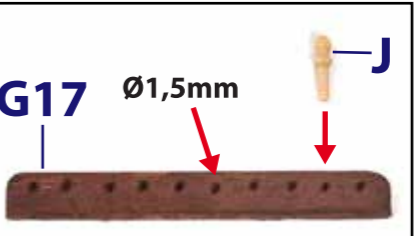
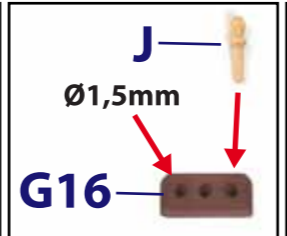
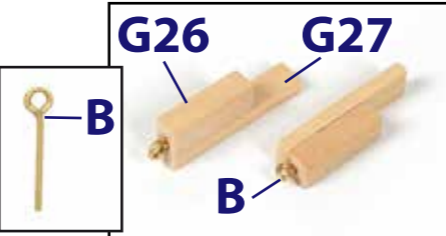
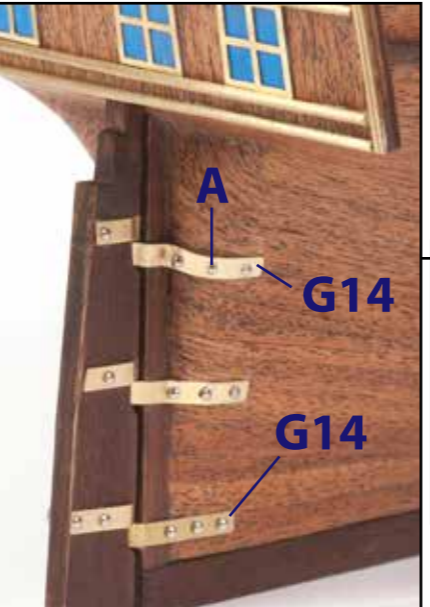
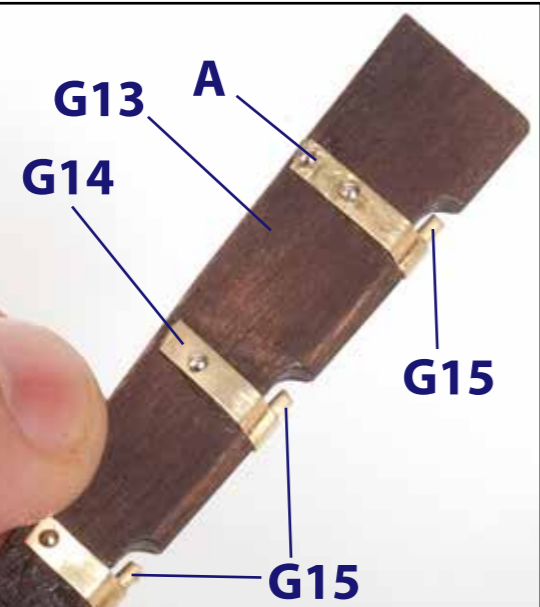
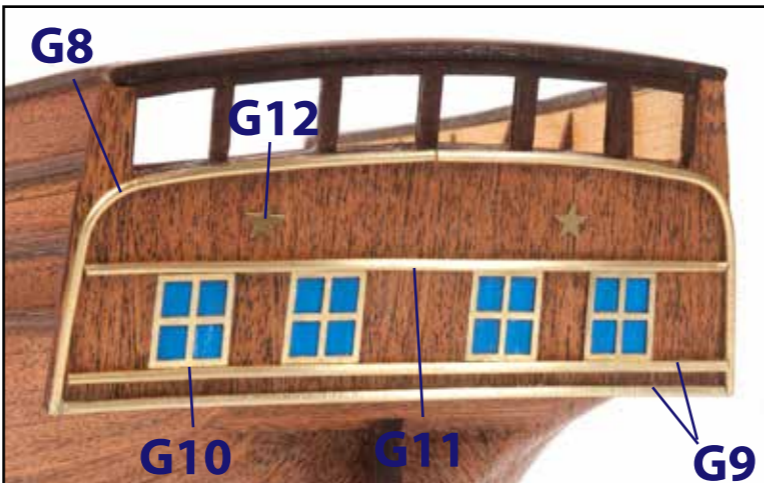
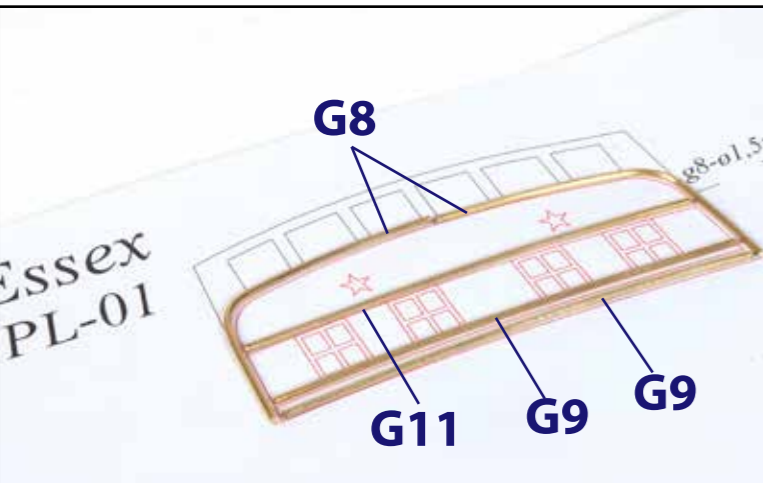
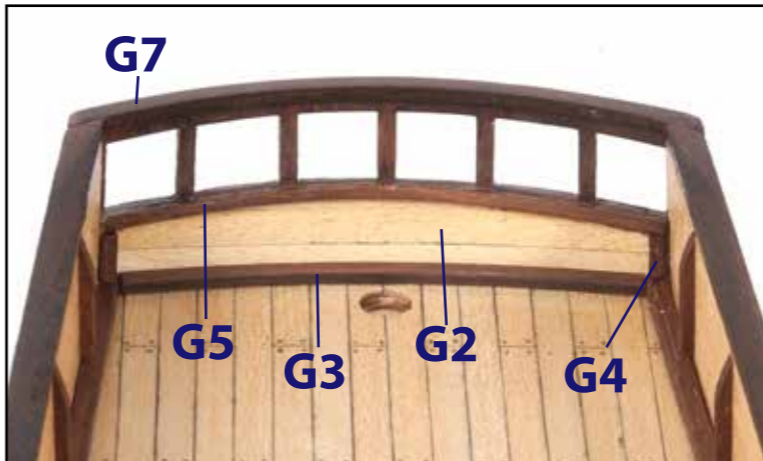
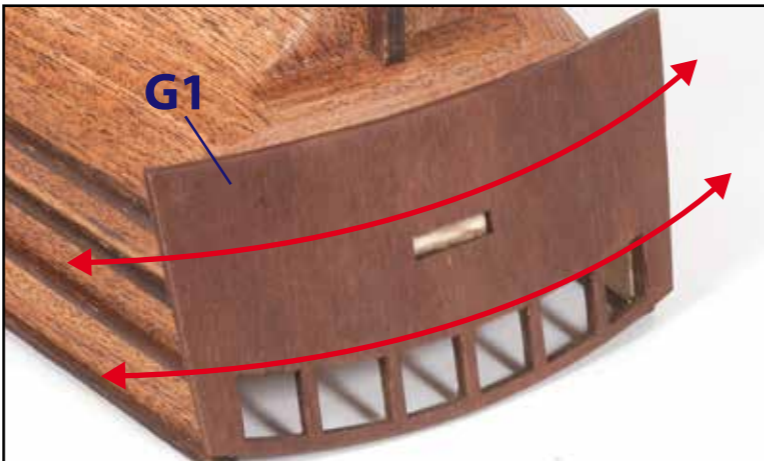

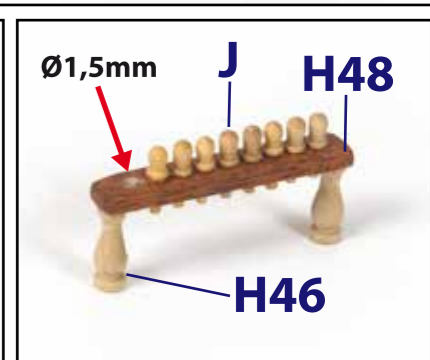
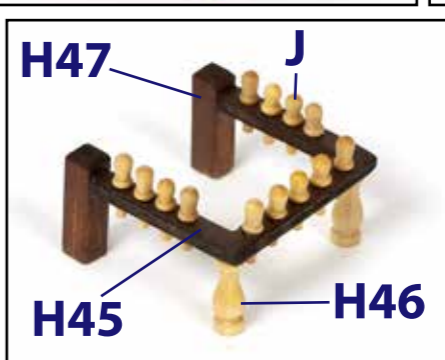
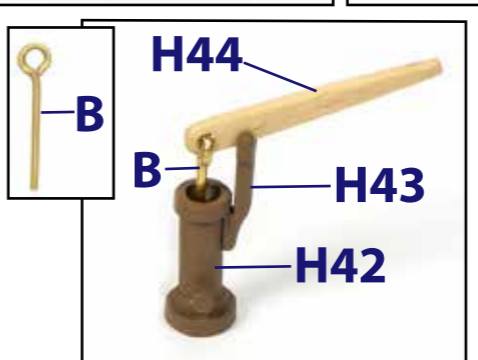
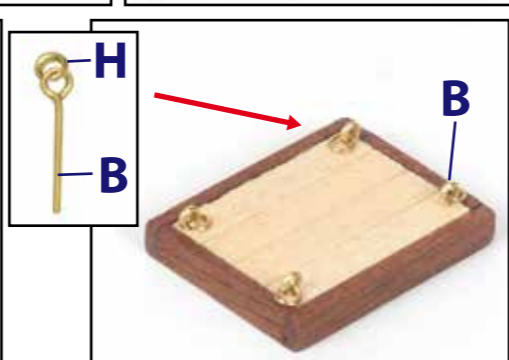
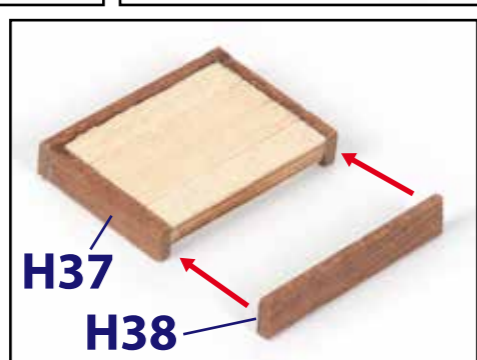
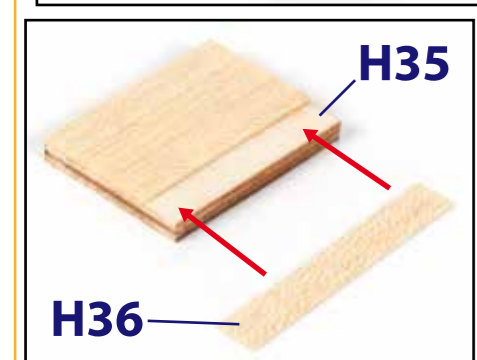
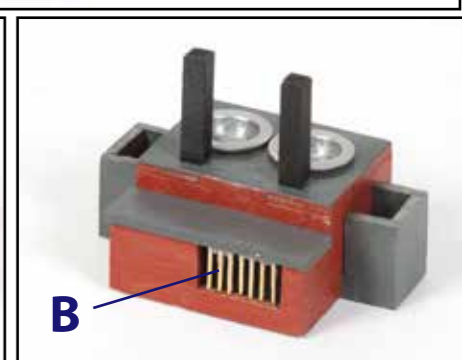
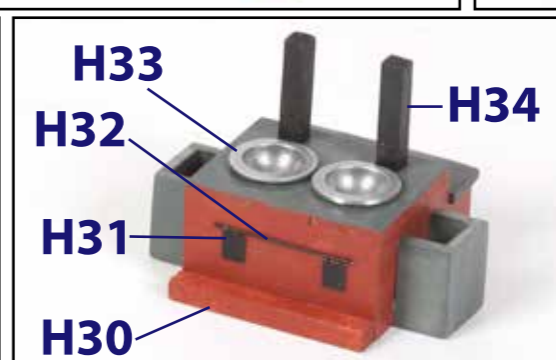
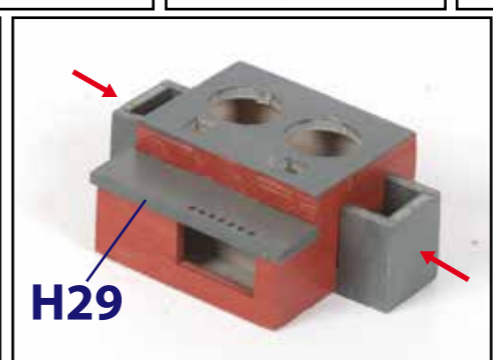
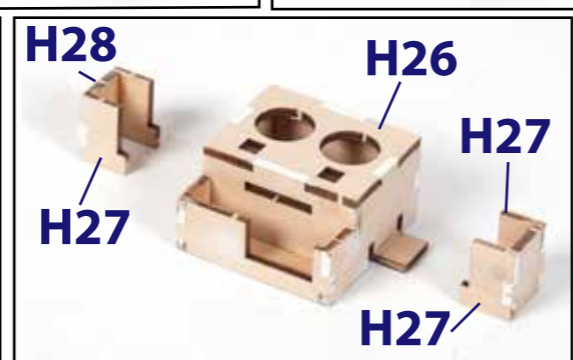
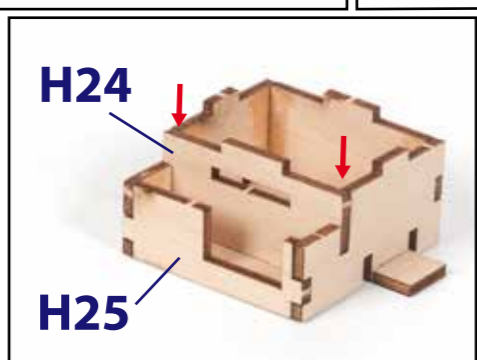
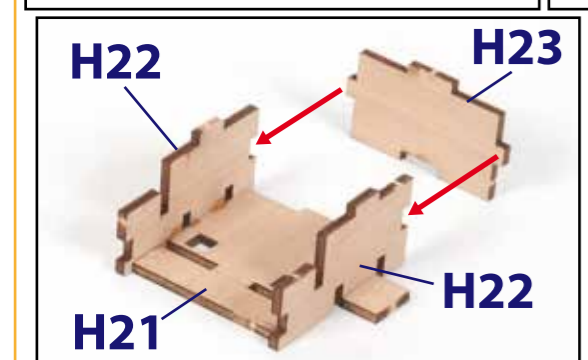
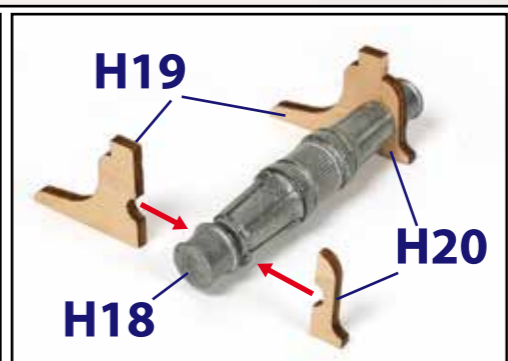
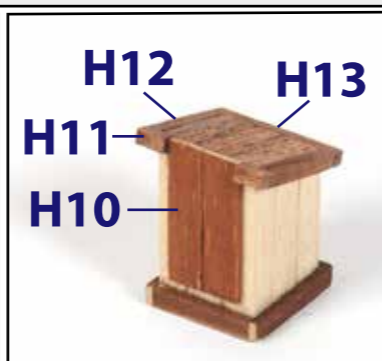
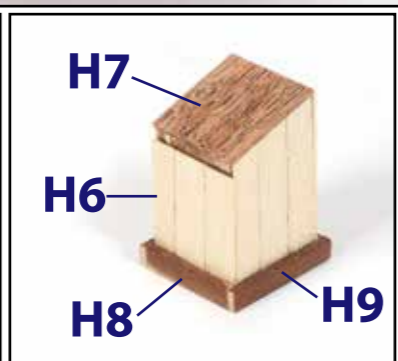
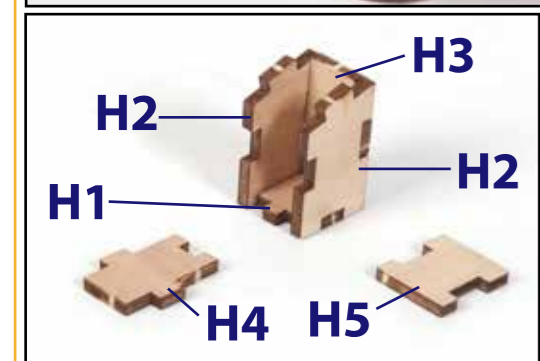
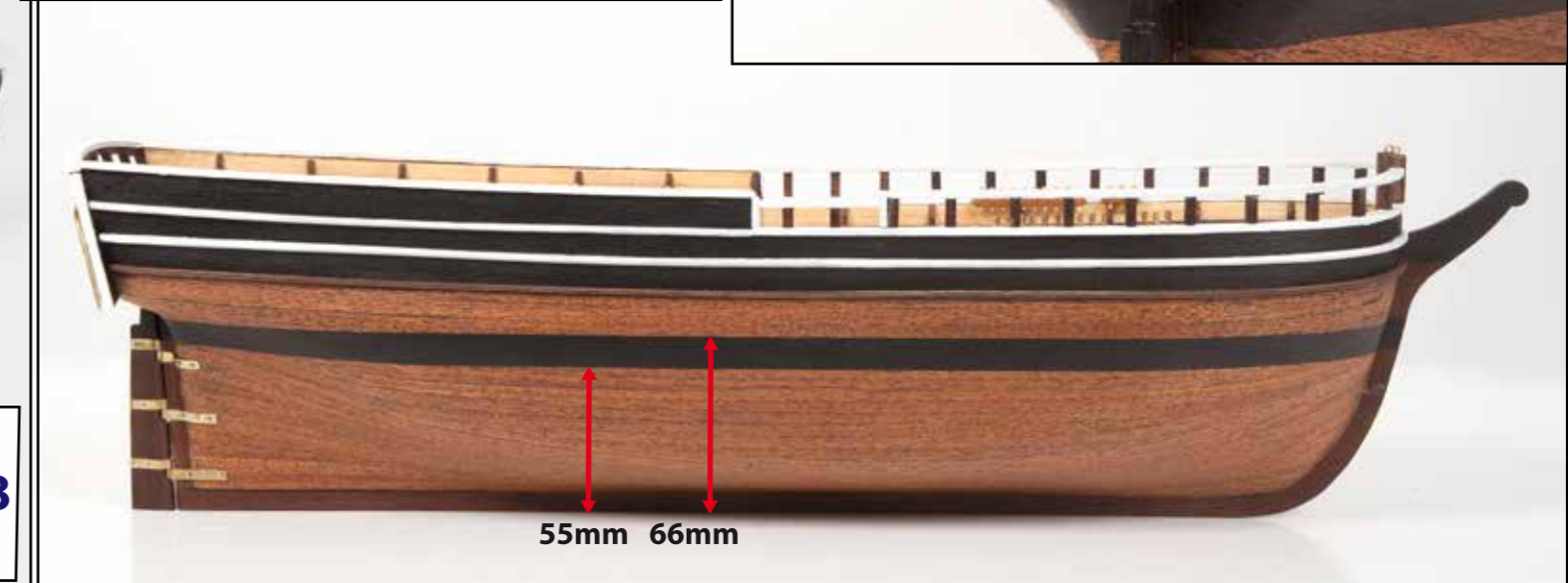
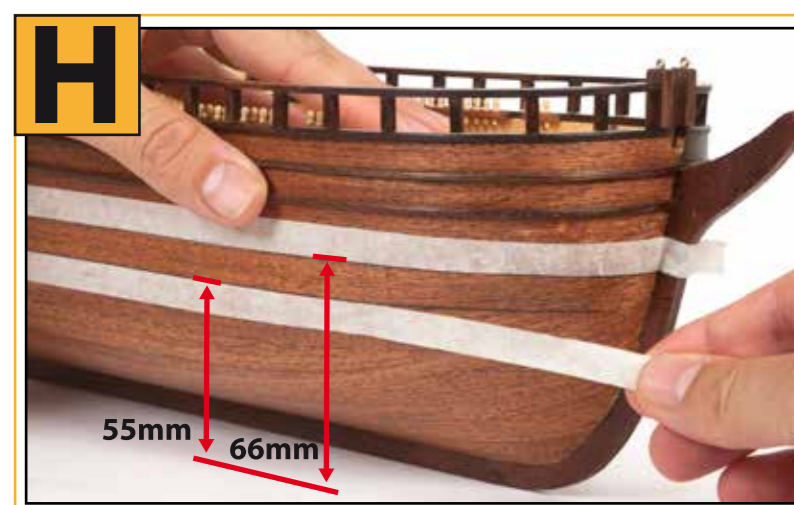
**H**

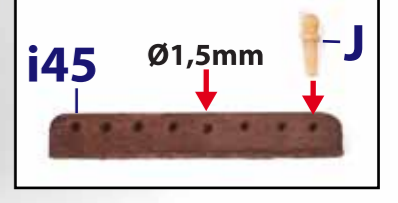
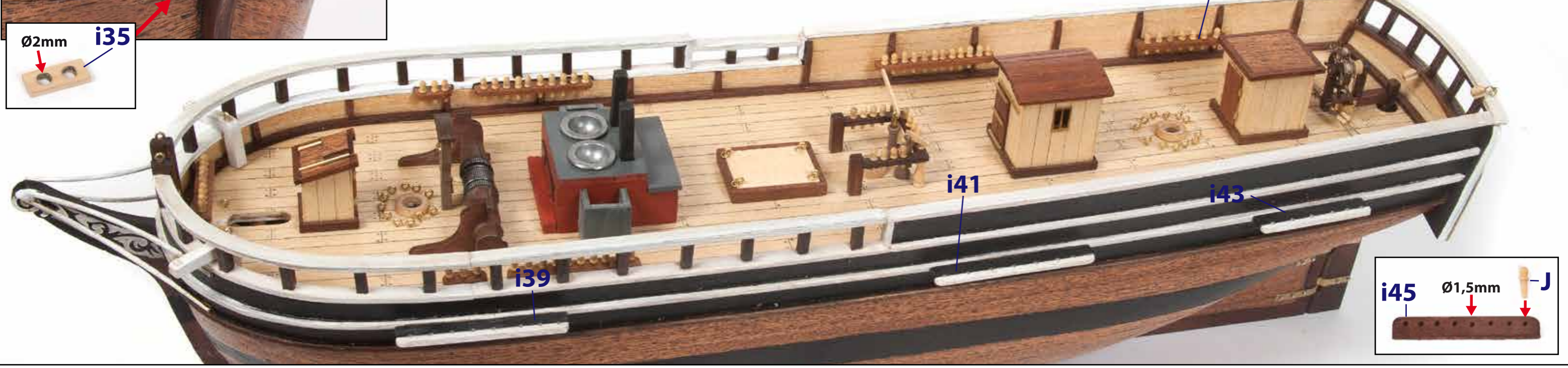
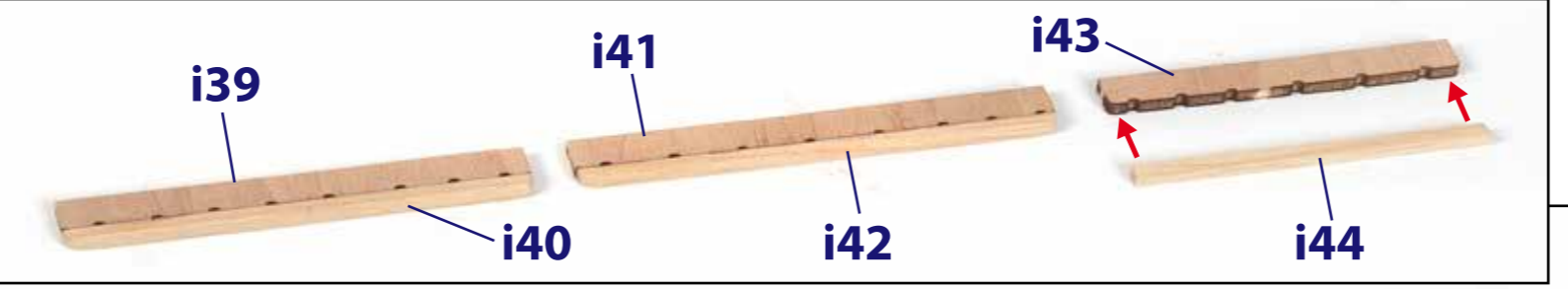
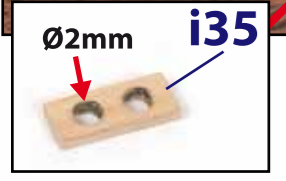
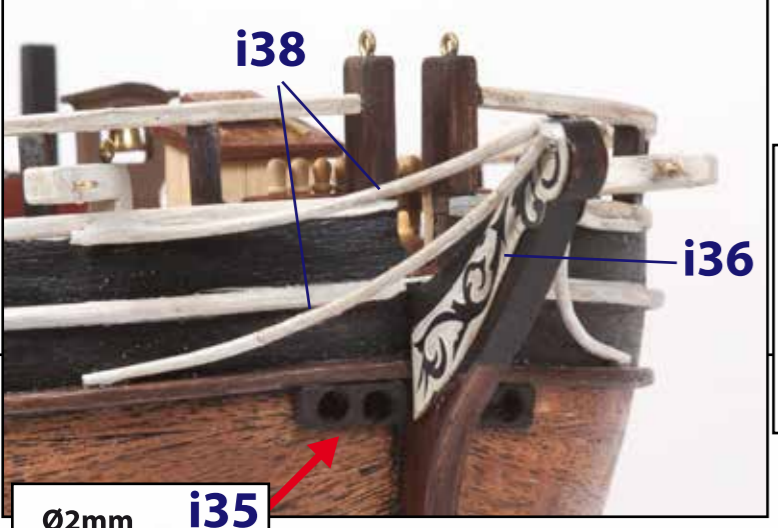
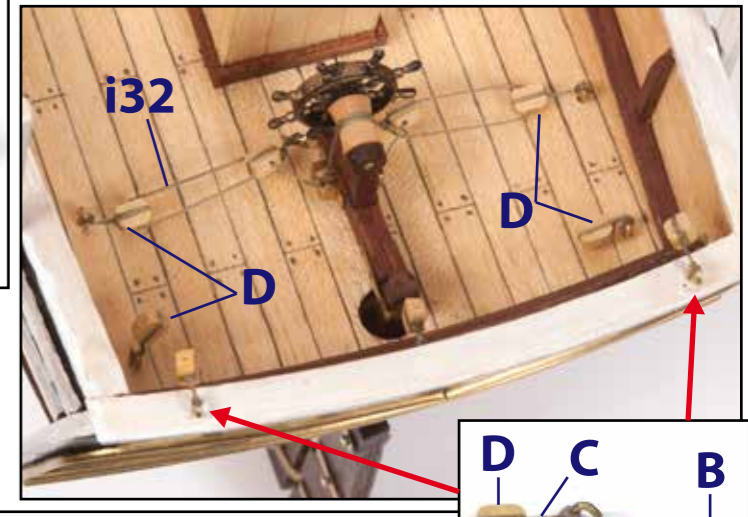
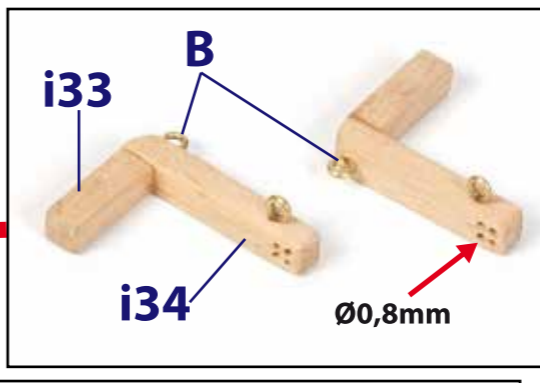
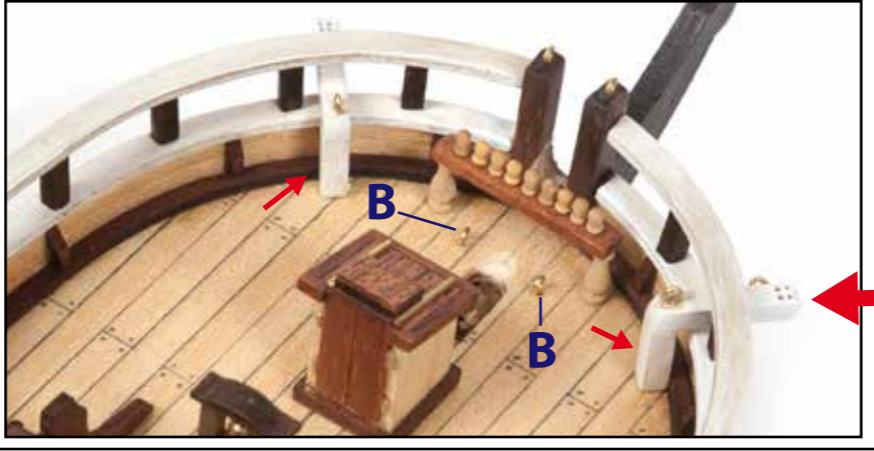
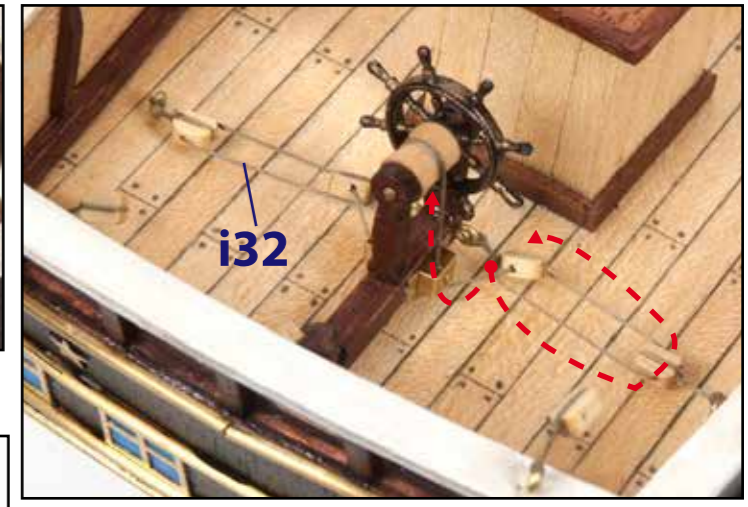
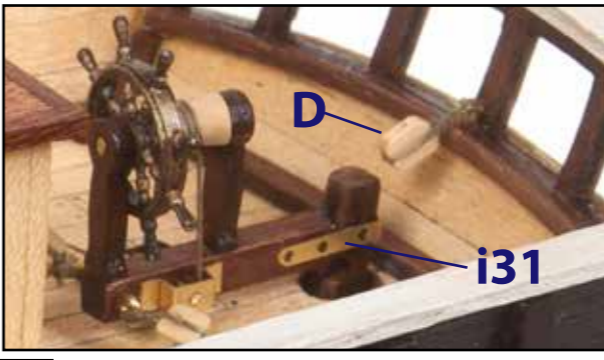
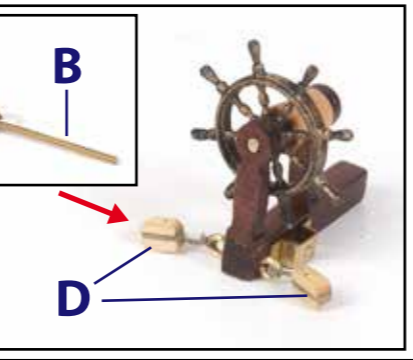
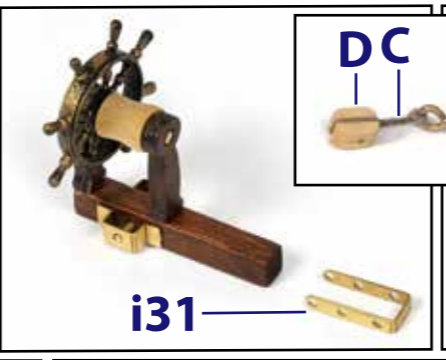
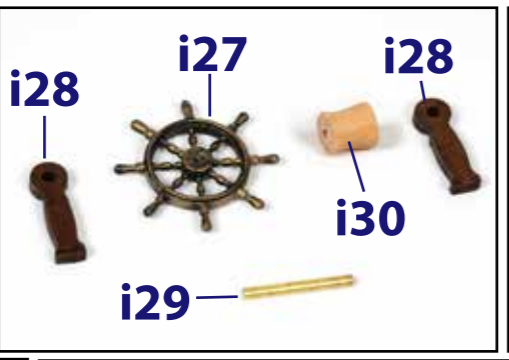
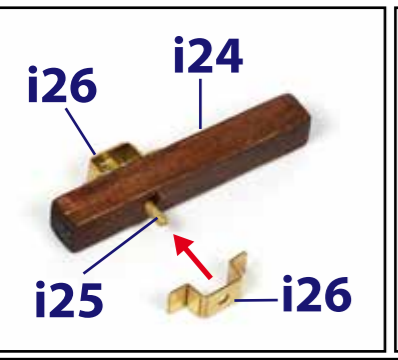
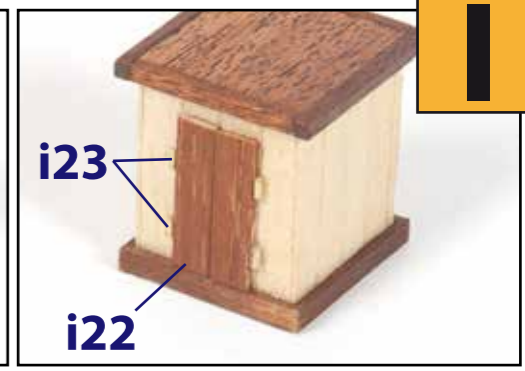
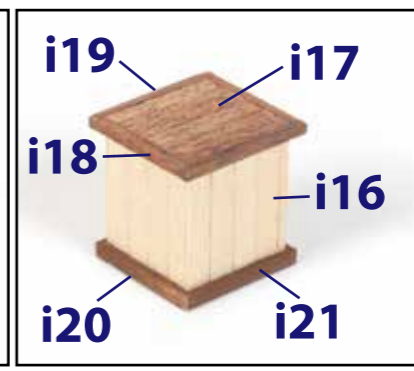
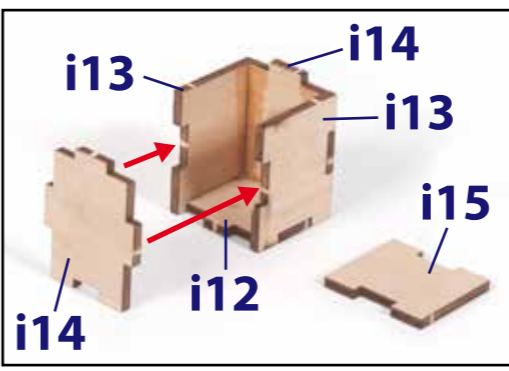
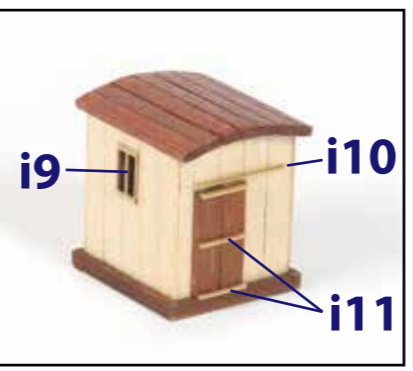
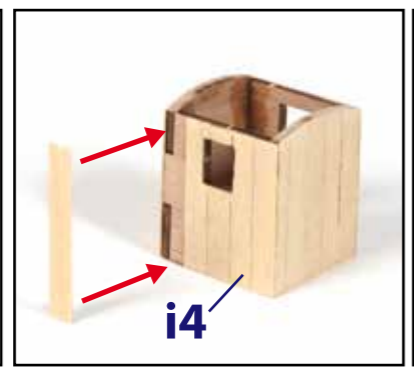
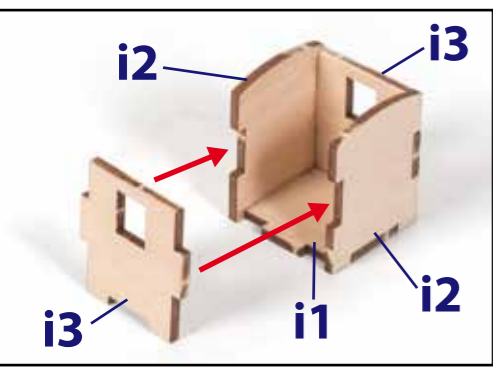

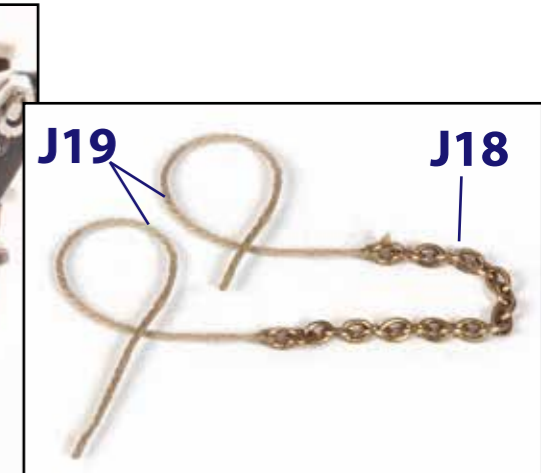
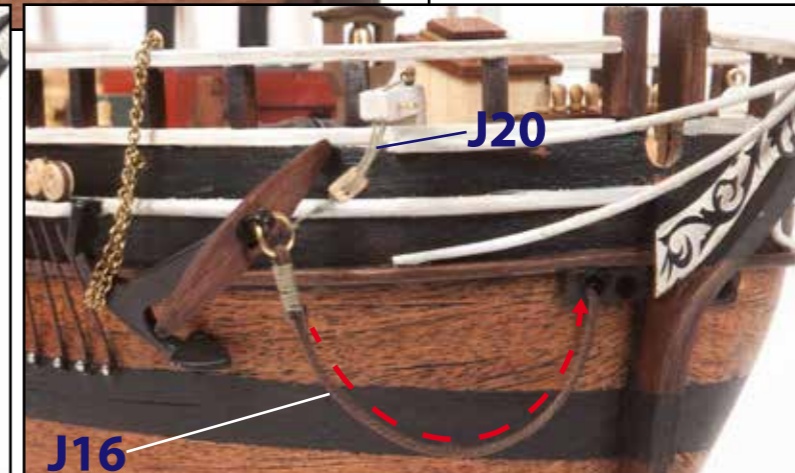
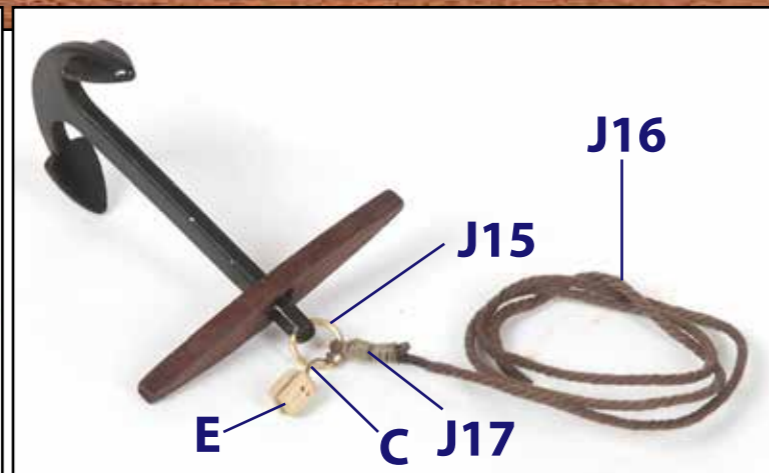
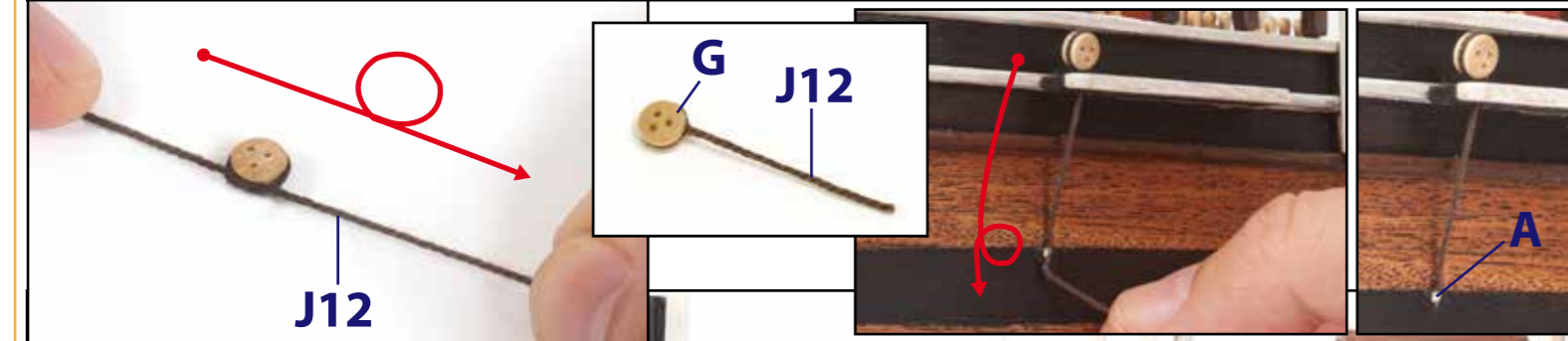
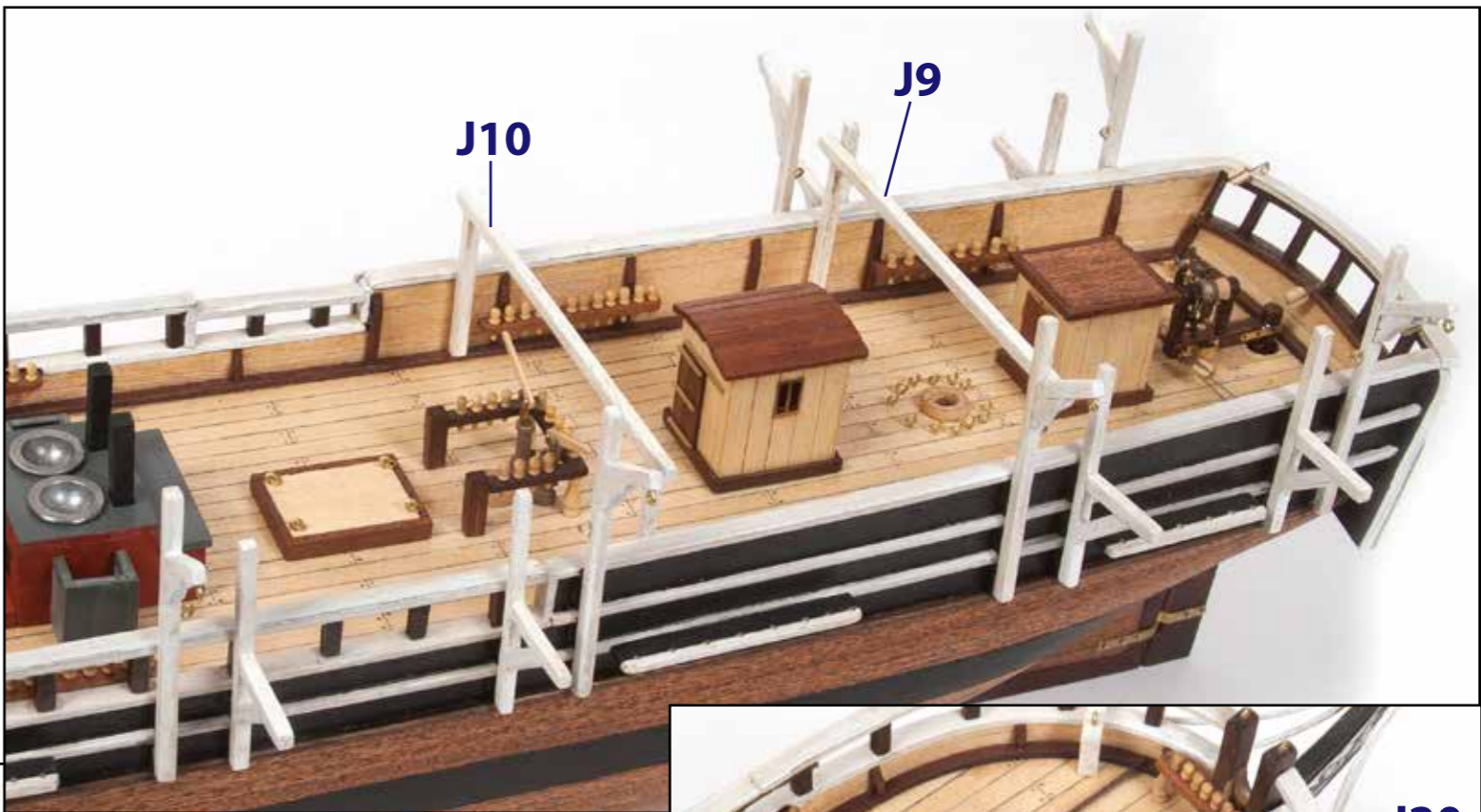
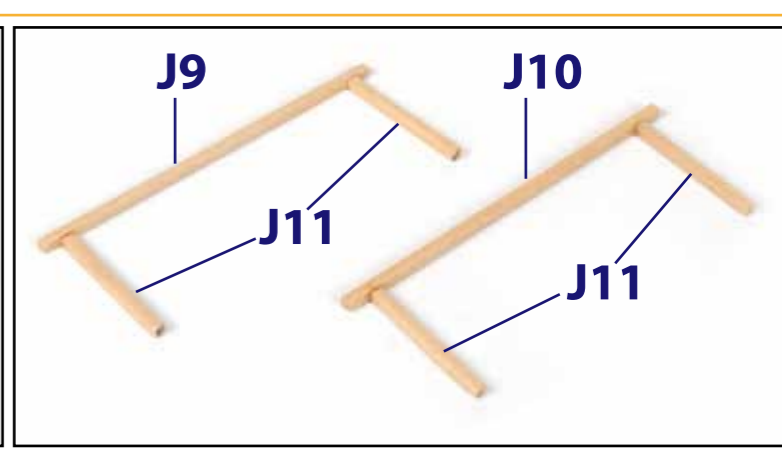
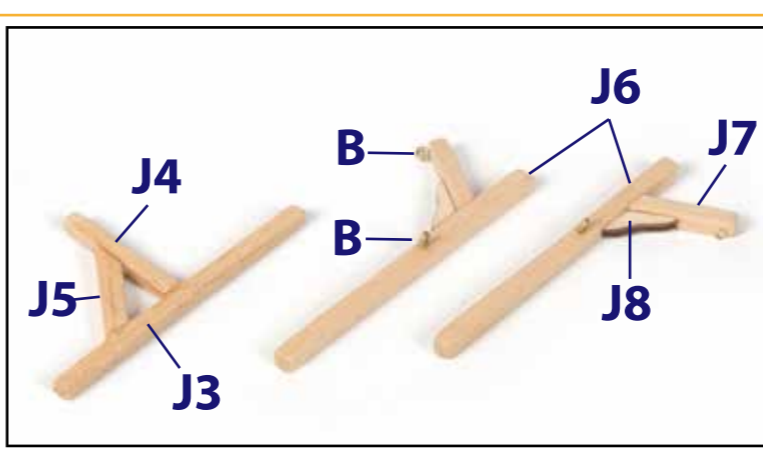
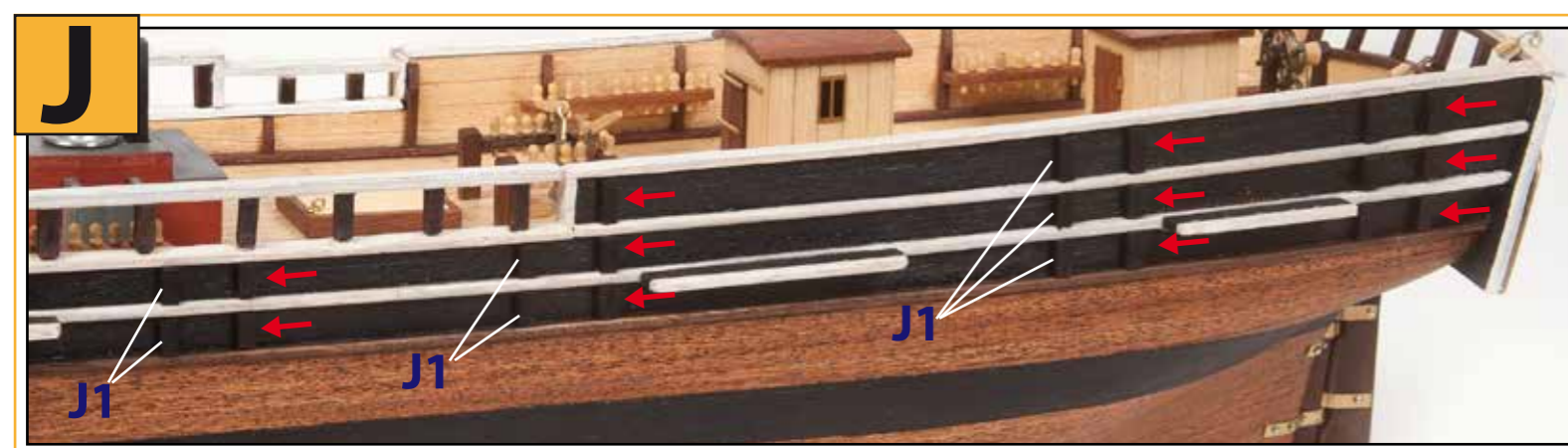

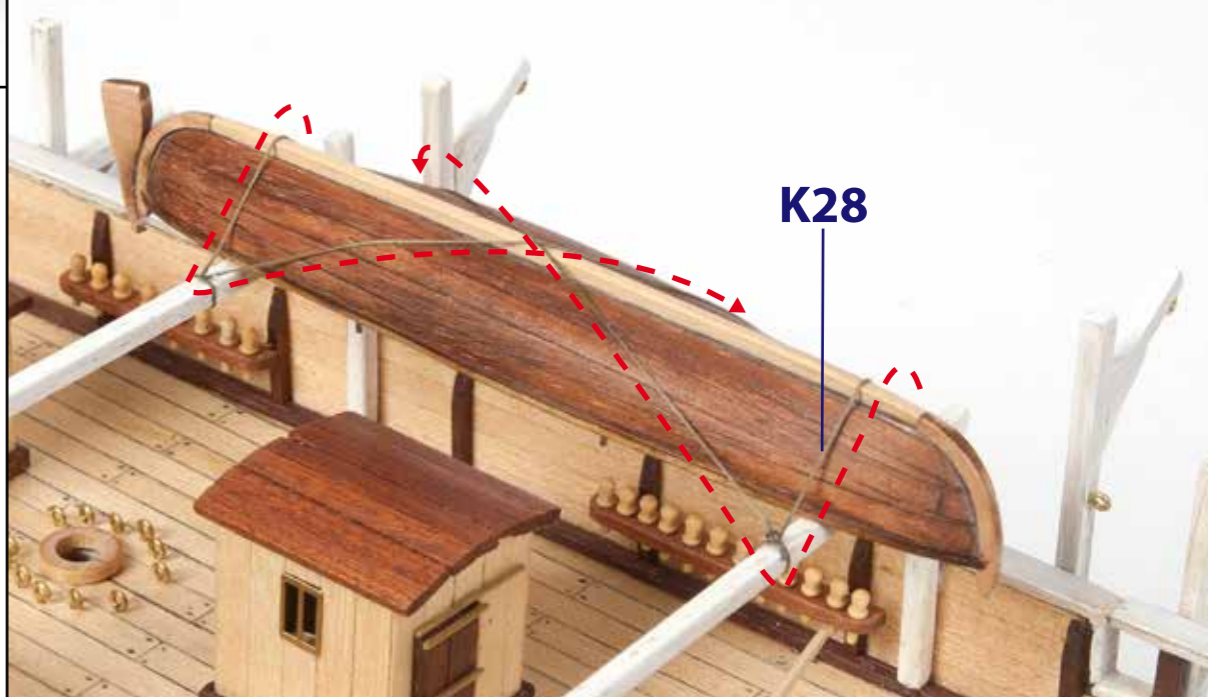
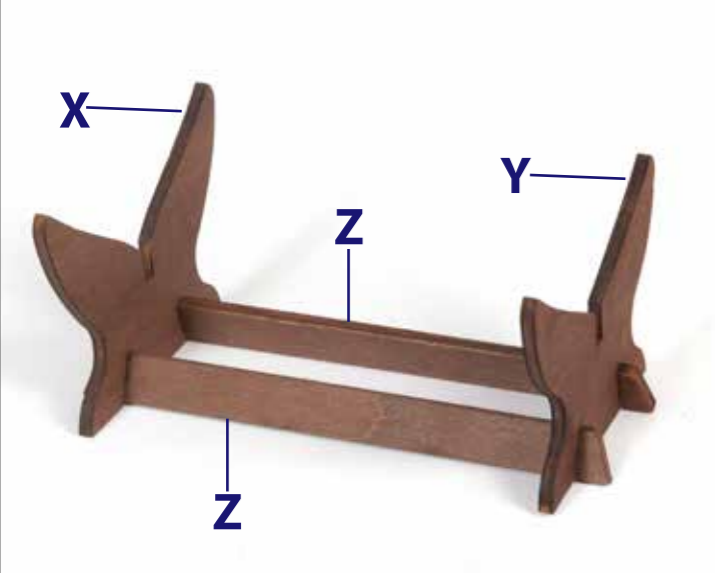
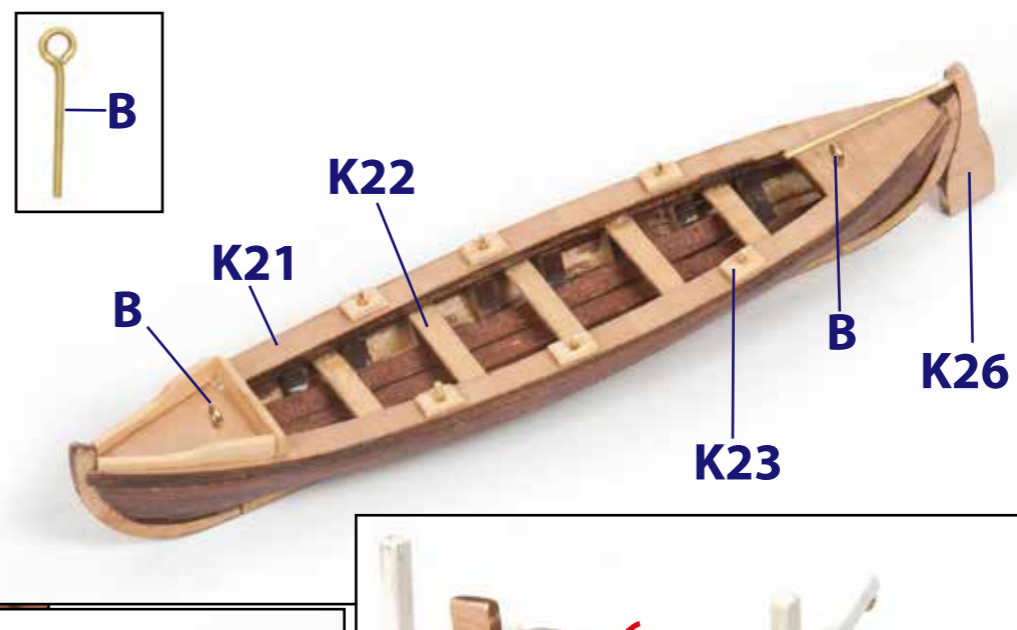
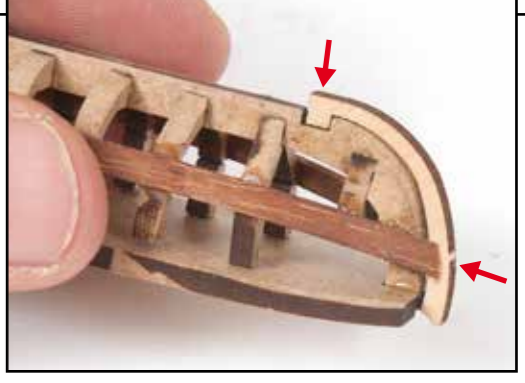
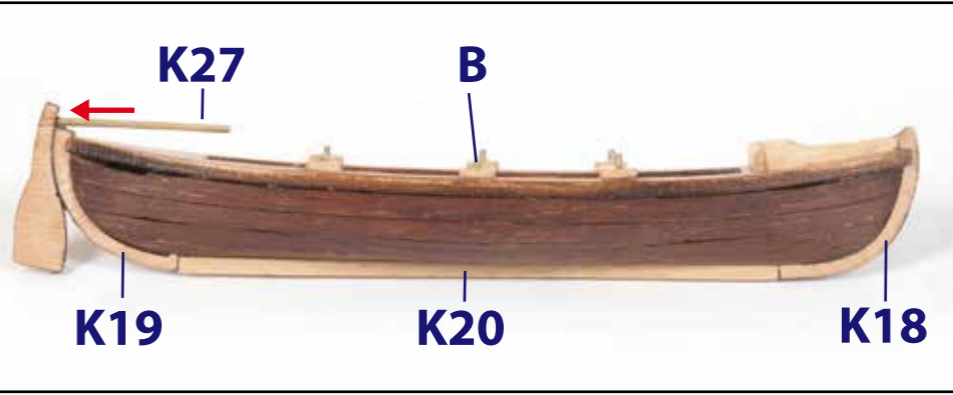
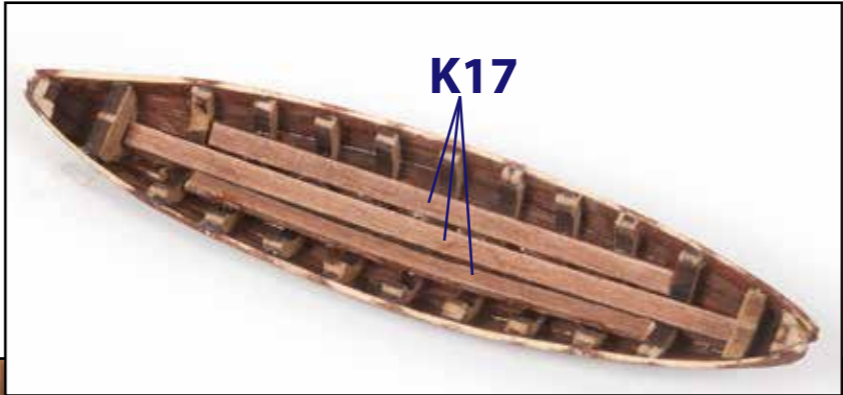
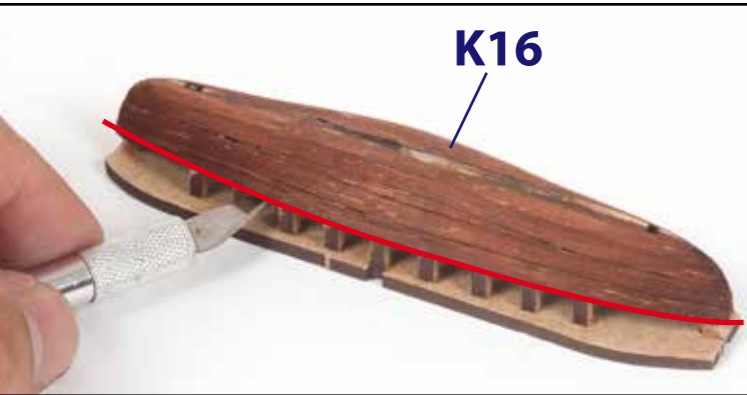
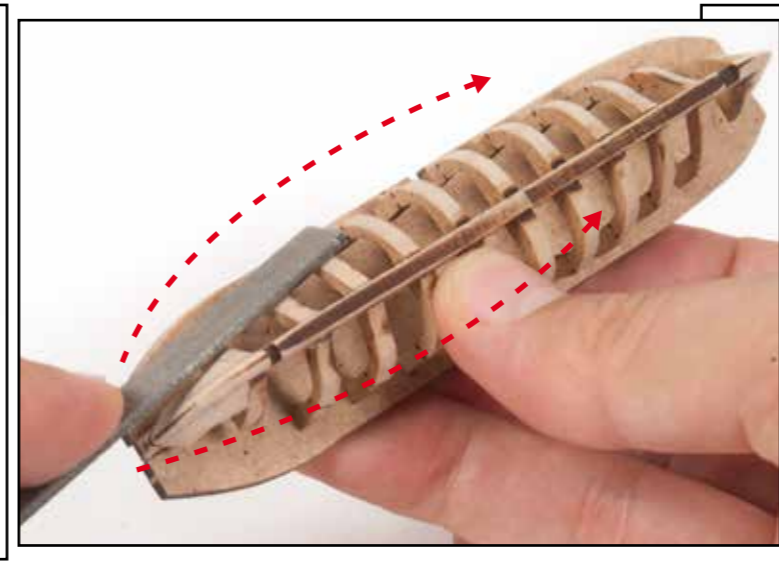
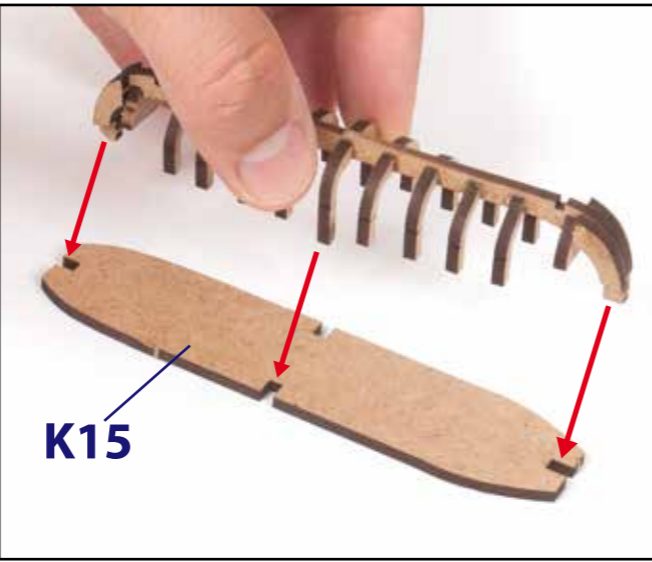
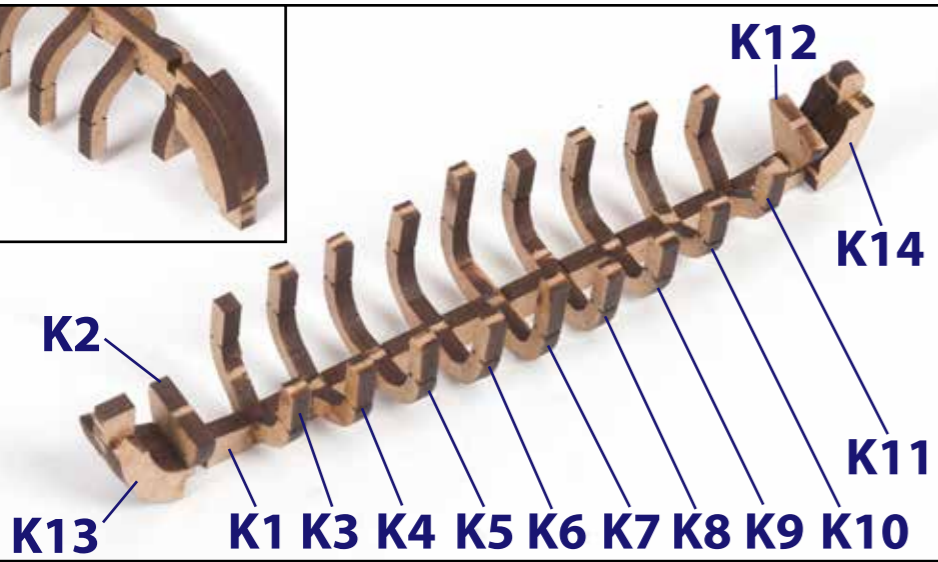

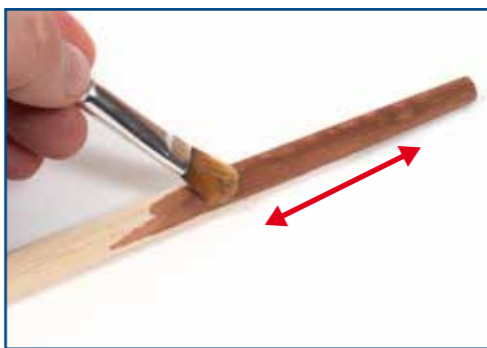
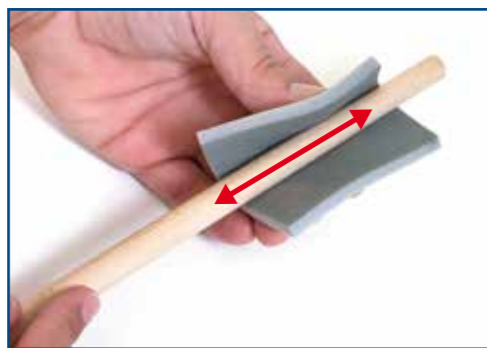

Consultar los planos de mástiles  
Consult the masts drawings  
Consulte os desenhos dos mastros  
Consulter les dessins des mâts  
Konsultieren Sie die Mastenzeichnungen  
Обратитесь к рисункам мачты  
Consultare i disegni degli alberi

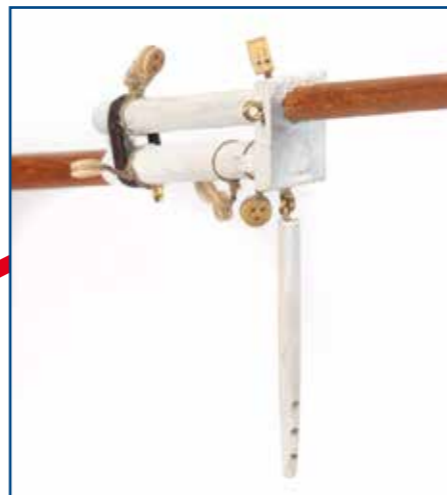
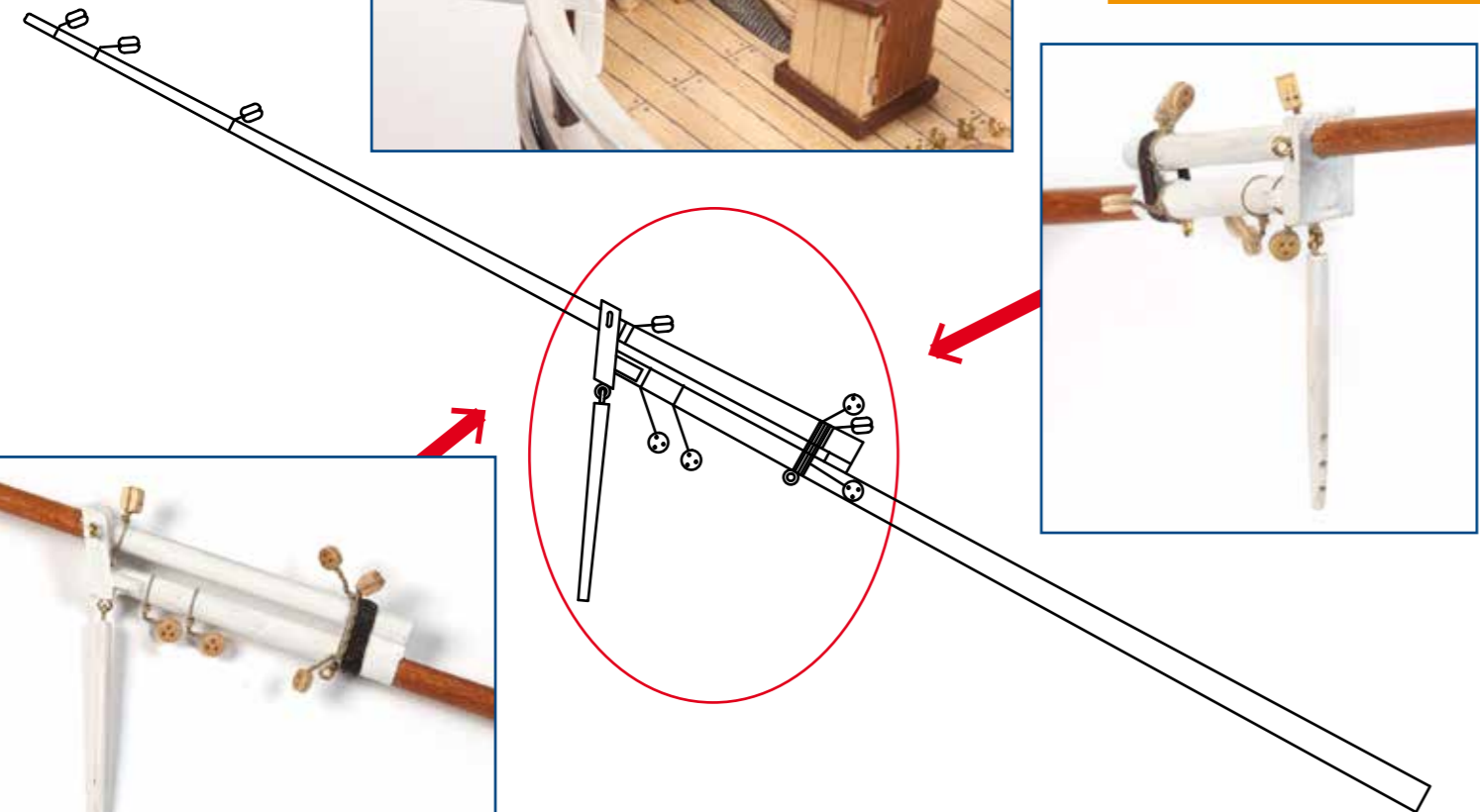
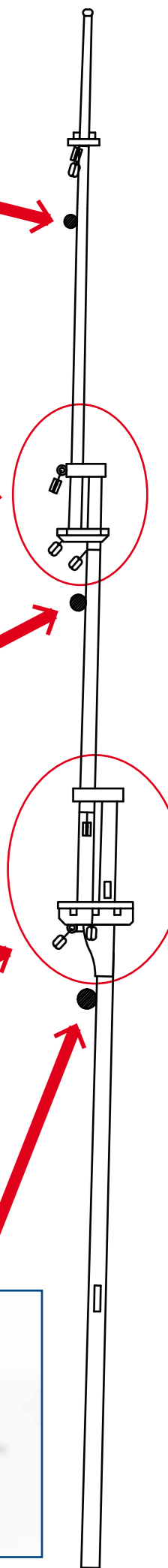
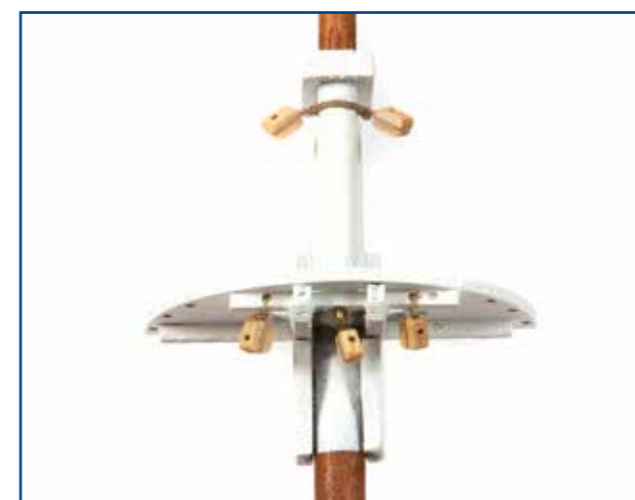



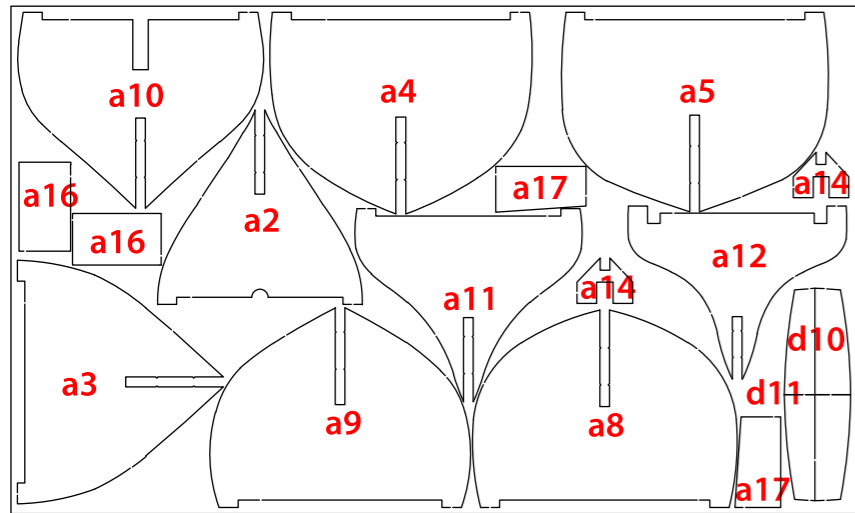

12006-2

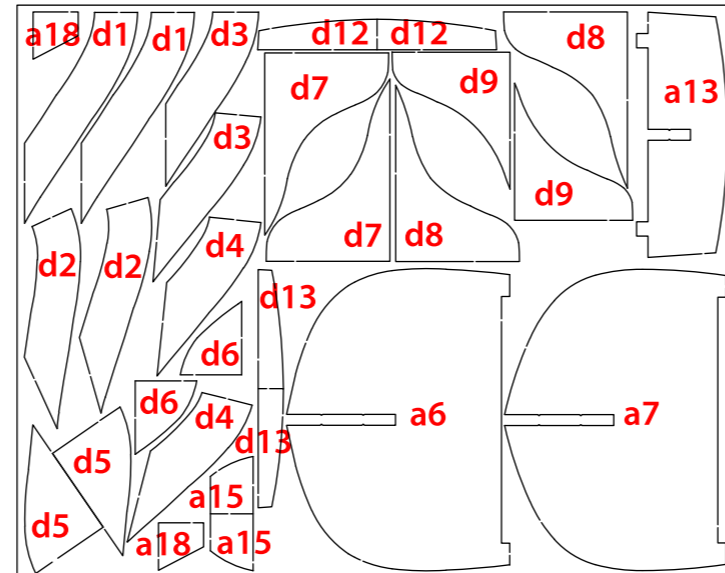

12006-3

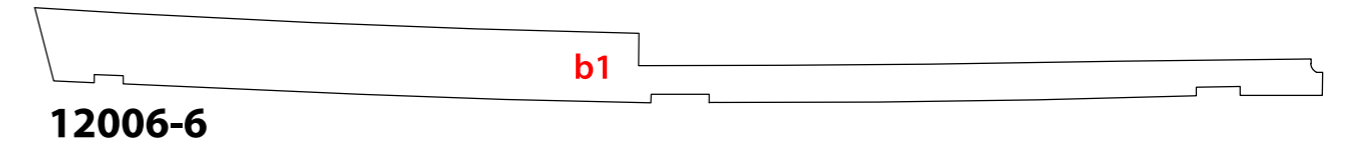

12006-6

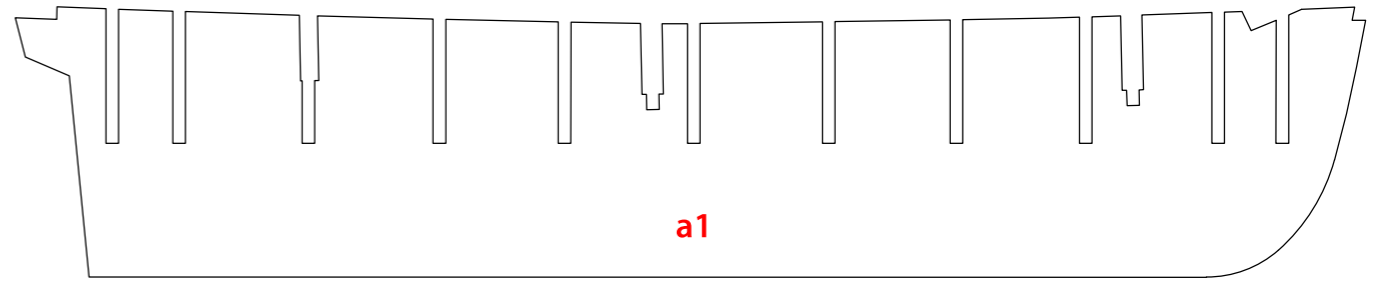

12006-1

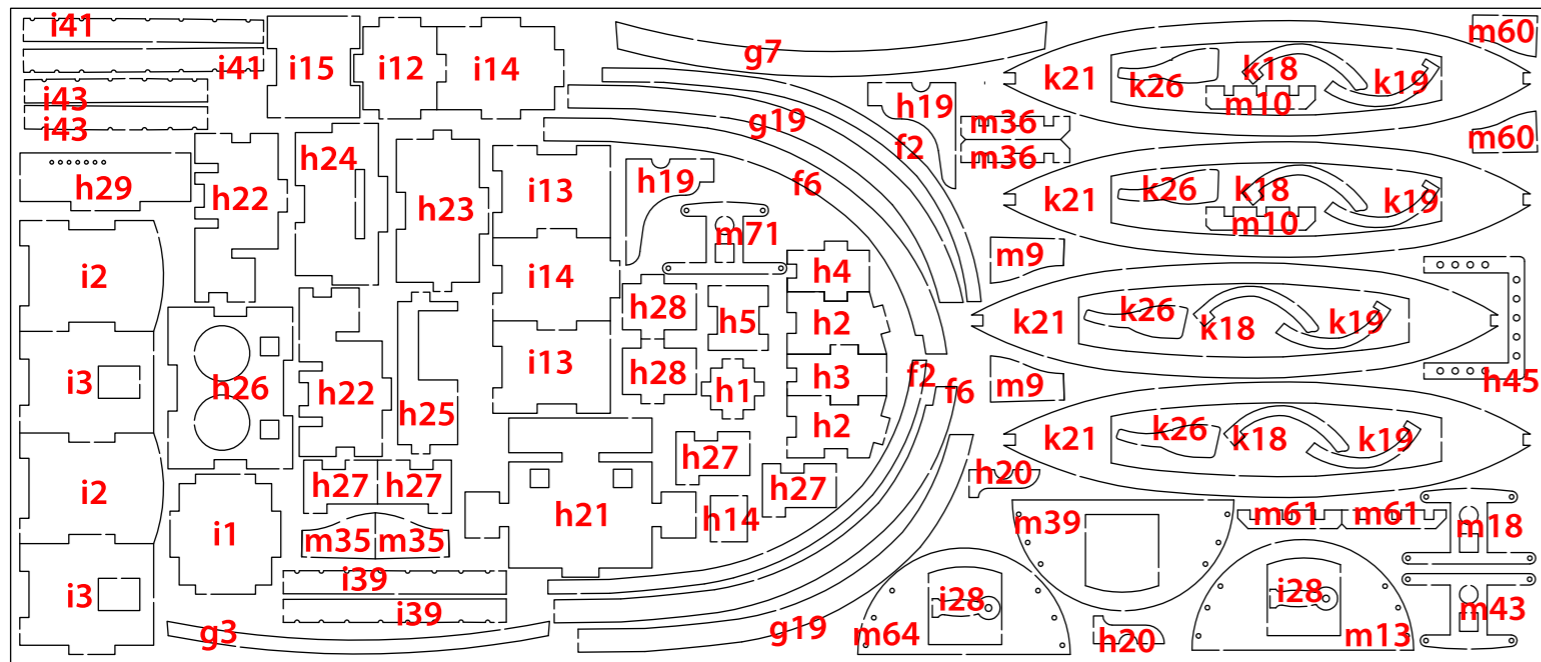

12006-7

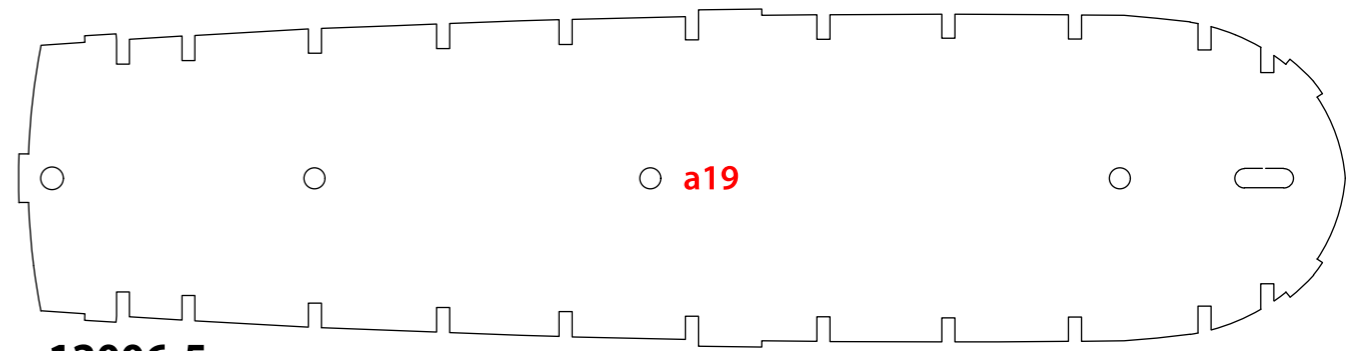

12006-5

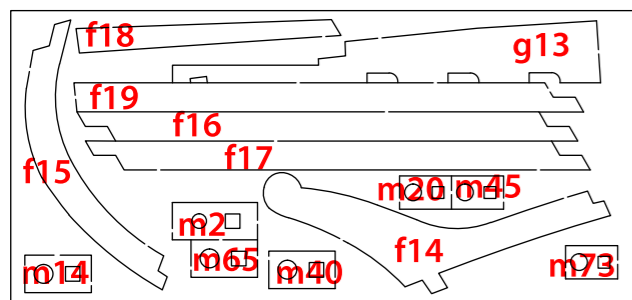

12006-4

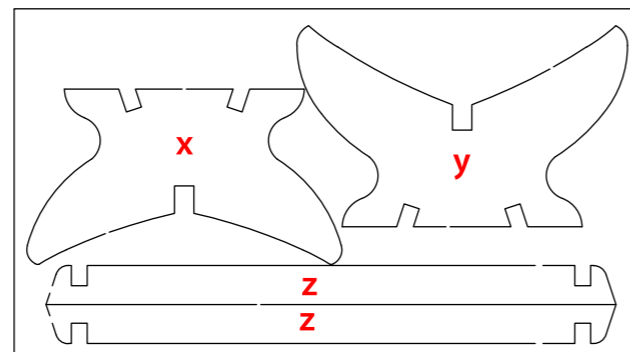

12006-11

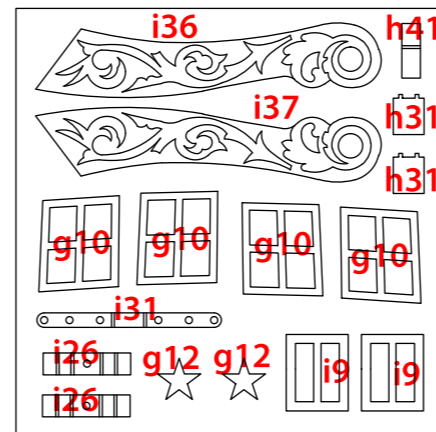

12006-10

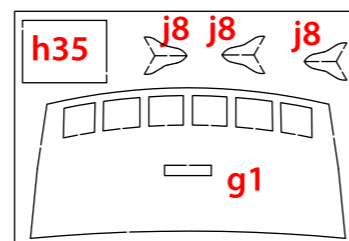

12006-9

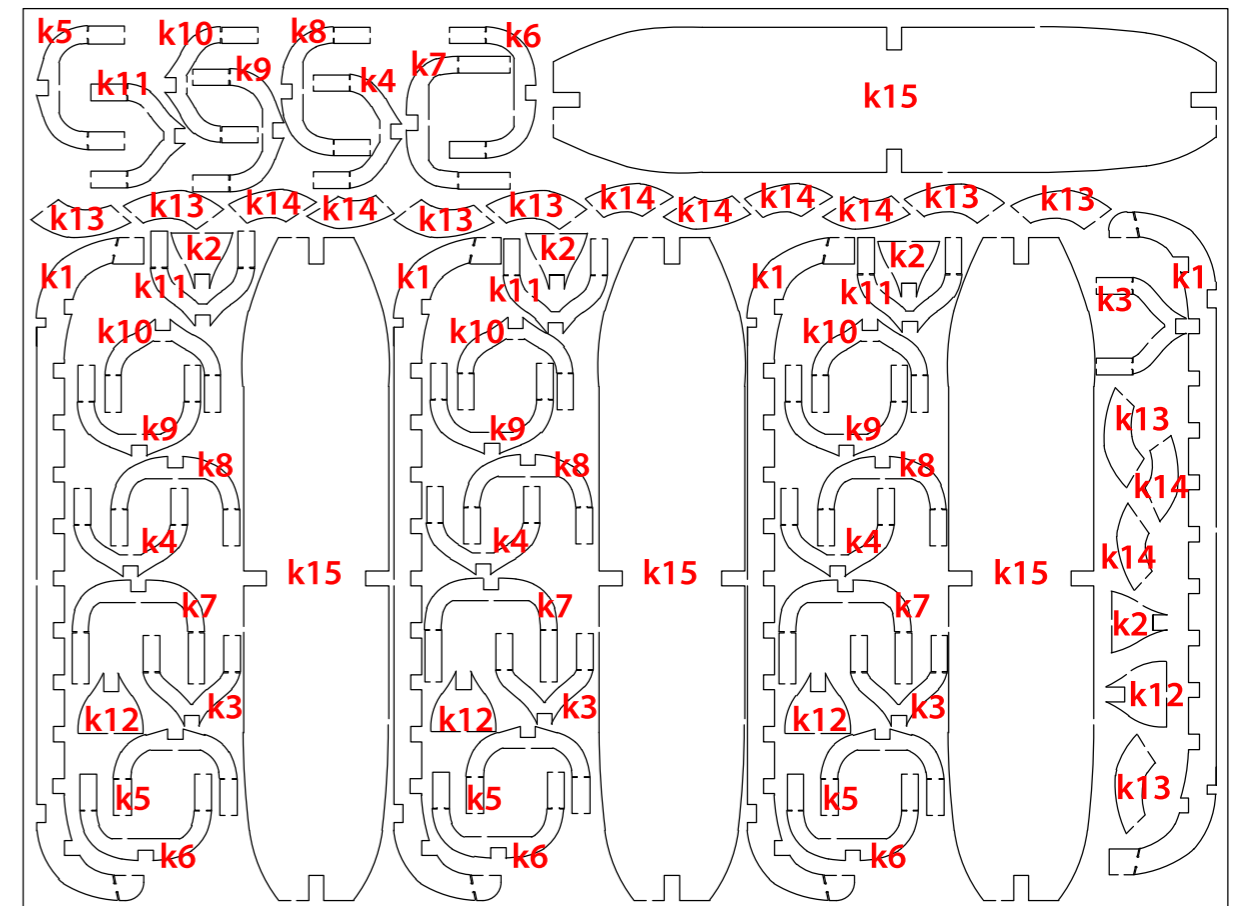

12006-8





# Essex PL-01

g8- $\phi$ 1,5x100mm

g9- $\phi$ 1,5x100mm

g8- $\phi$ 1,5x100mm

g11- $\phi$ 1,5x100mm

j14-3x3x40mm  
x4

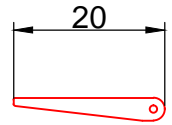

h44-1x3x20mm  
x2

j7-3x3x20mm  
x6

j3-3x3x50mm  
x6

j4-3x3x22mm  
x6

j5-3x3x20mm  
x6

k29

j8  
x6

j6-3x3x65mm  
x6

j20

i34

i34-4x4x22mm  
x2

i33-4x4x12mm  
x2

Scale 1/1

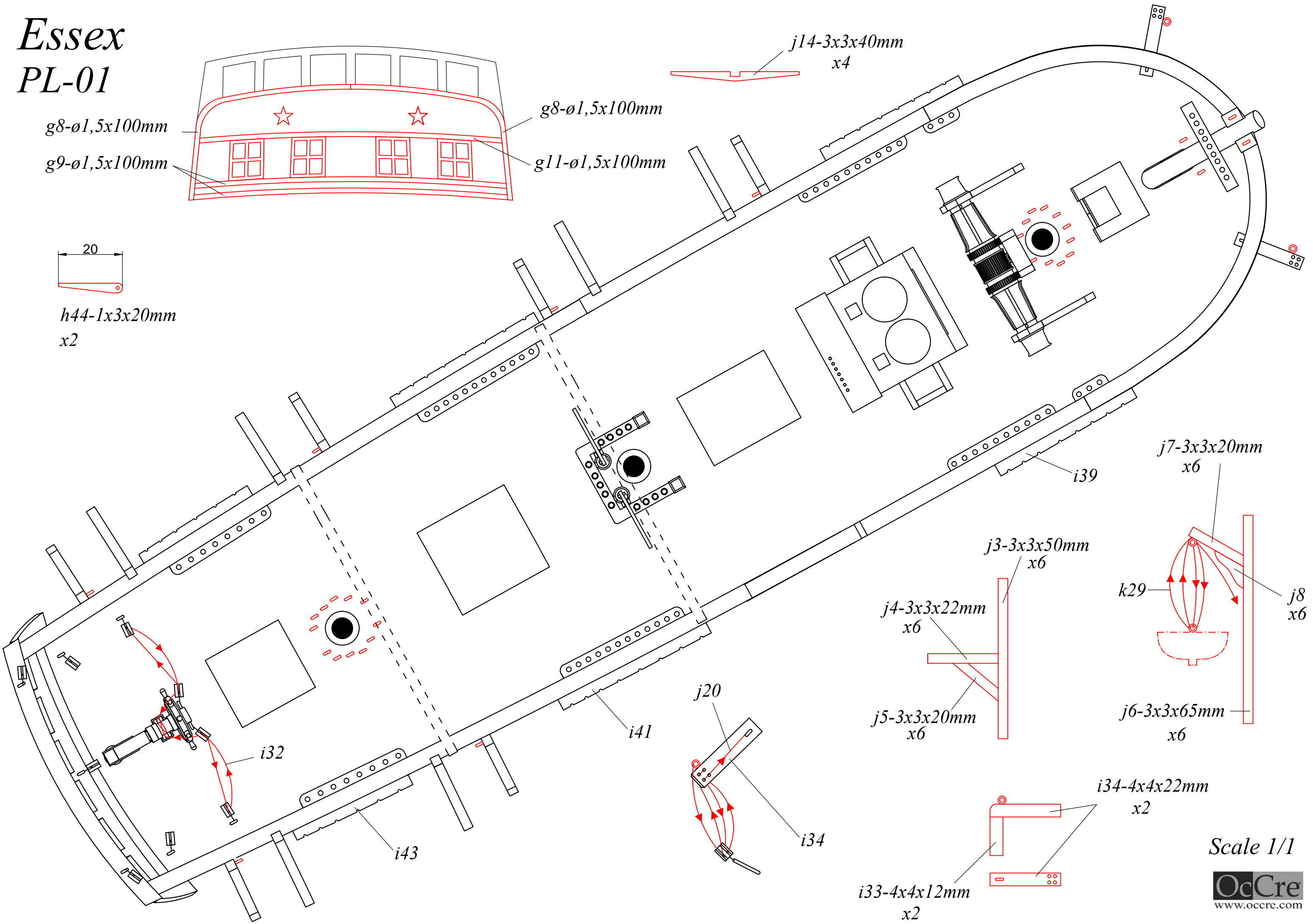

# Essex

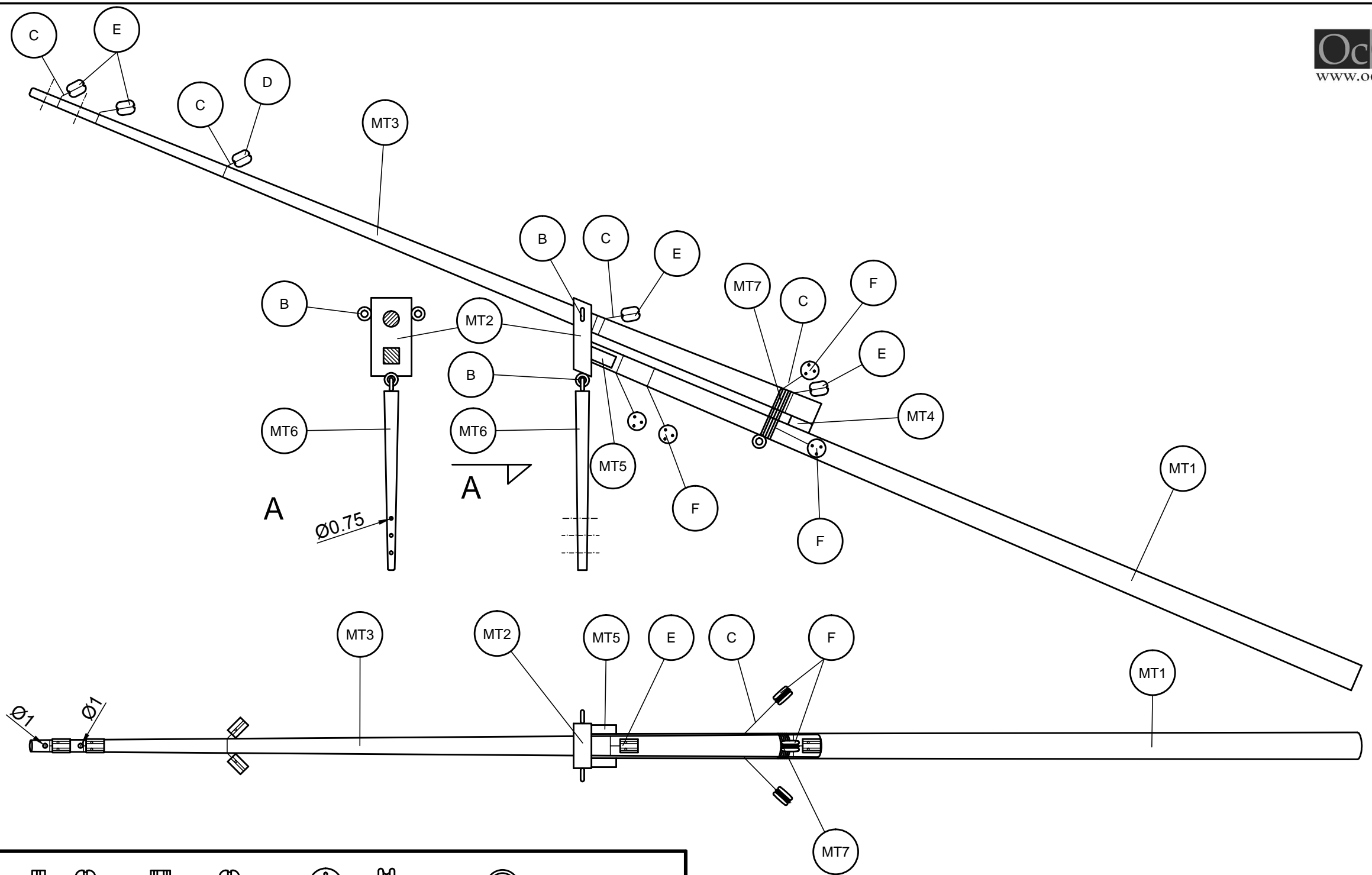
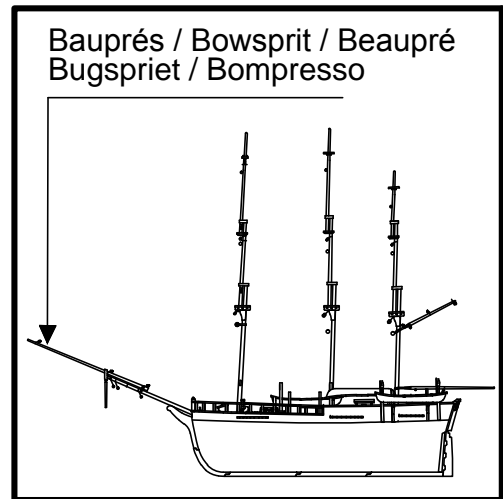

A	B	D	E	F-G	H-I	J
Punta	Cáncamo	Moton	Cuadernal	Vigota	Anilla	Cabilla
Pins	Eyebolts	Blocks	Double blocks	Dead eyes	Rings	Belaying Pins
Pointes	Piton à oeil	Poulie	Poulie double	Cap de mouton	Oeil	Chevilles
Drahtstifte	Tragöse	Blockrolle	Block	Jungferblock	Öse	Rundeisen
Punte	Cavilie di ferro ad anello	Bozzello	Costale	Bigotta	Anello	Caviglia

Scale 1/1

MT1	ø6x191	Tilo / Lime wood / Tilleul / Linde / Tiglio	MT7	ø0,50x100	Hilo marrón / Brown thread / Fil brun /braunes Baumwollfaden / Filo marrone
MT2	Precortado / Precut / Prédécoupé / Vorgeschnitten / Pretagliato	Tablero / Plywood / Planche / Sperrholz / Tavola	B	15	Latón / Brass / Laiton / Messing / Ottone
MT3	ø5x190	Tilo / Lime wood / Tilleul / Linde / Tiglio	C	ø0,15x100	Hilo crudo / Raw thread / Fil brut / Rohes Baumwollfaden / Filo crudo
MT4	2x2x5	Tilo / Lime wood / Tilleul / Linde / Tiglio	D	4	Composite / Composite / Composite / Composite / Composite
MT5	2x2x7	Tilo / Lime wood / Tilleul / Linde / Tiglio	E	4	Composite / Composite / Composite / Composite / Composite
MT6	ø3x40	Tilo / Lime wood / Tilleul / Linde / Tiglio	F	ø4	Composite / Composite / Composite / Composite / Composite

Palo trinquete / Fore mast  
Mât de misaine / Fockmast  
Albero trinchetto

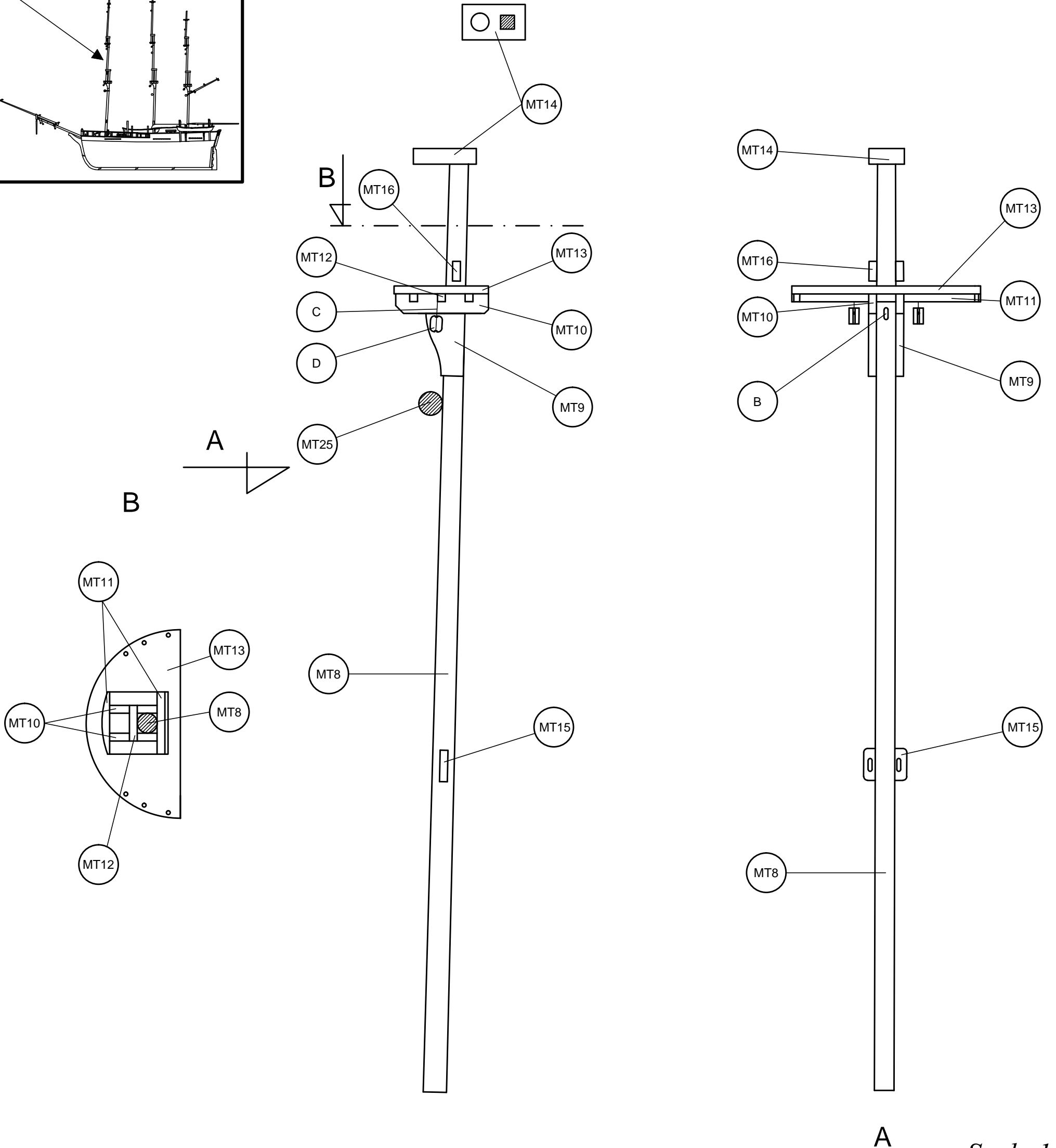
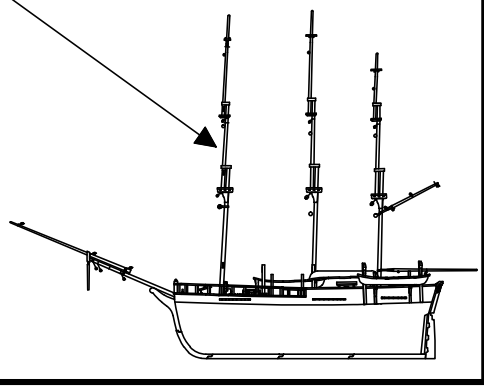

Scale 1/1

MT8	ø6x240	Tilo / Lime wood / Tilleul / Linde / Tiglio	MT15	2x3x8	Tilo / Lime wood / Tilleul / Linde / Tiglio
MT9	Precortado / Precut / Prédécoupé / Vorgeschnitten/ Pretagliato	Tablero / Plywood / Planche / Sperrholz / Tavola	MT16	2x3x5	Tilo / Lime wood / Tilleul / Linde / Tiglio
MT10	Precortado / Precut / Prédécoupé / Vorgeschnitten/ Pretagliato	Tablero / Plywood / Planche / Sperrholz / Tavola	B	15	Latón / Brass / Laiton / Messing / Ottone
MT11	2x2x47	Tilo / Lime wood / Tilleul / Linde / Tiglio	C	ø0,15x100	Hilo crudo / Raw thread / Fil brut / Rohes Baumwollfaden / Filo crudo
MT12	2x2x9	Tilo / Lime wood / Tilleul / Linde / Tiglio	D	4	Composite / Composite / Composite / Composite / Composite
MT13	Precortado / Precut / Prédécoupé / Vorgeschnitten/ Pretagliato	Tablero / Plywood / Planche / Sperrholz / Tavola	E	4	Composite / Composite / Composite / Composite / Composite
MT14	Precortado / Precut / Prédécoupé / Vorgeschnitten/ Pretagliato	Tablero / Plywood / Planche / Sperrholz / Tavola			

Palo trinquete / Fore mast / Mât de misaine  
Fockmast / Albero trinchetto

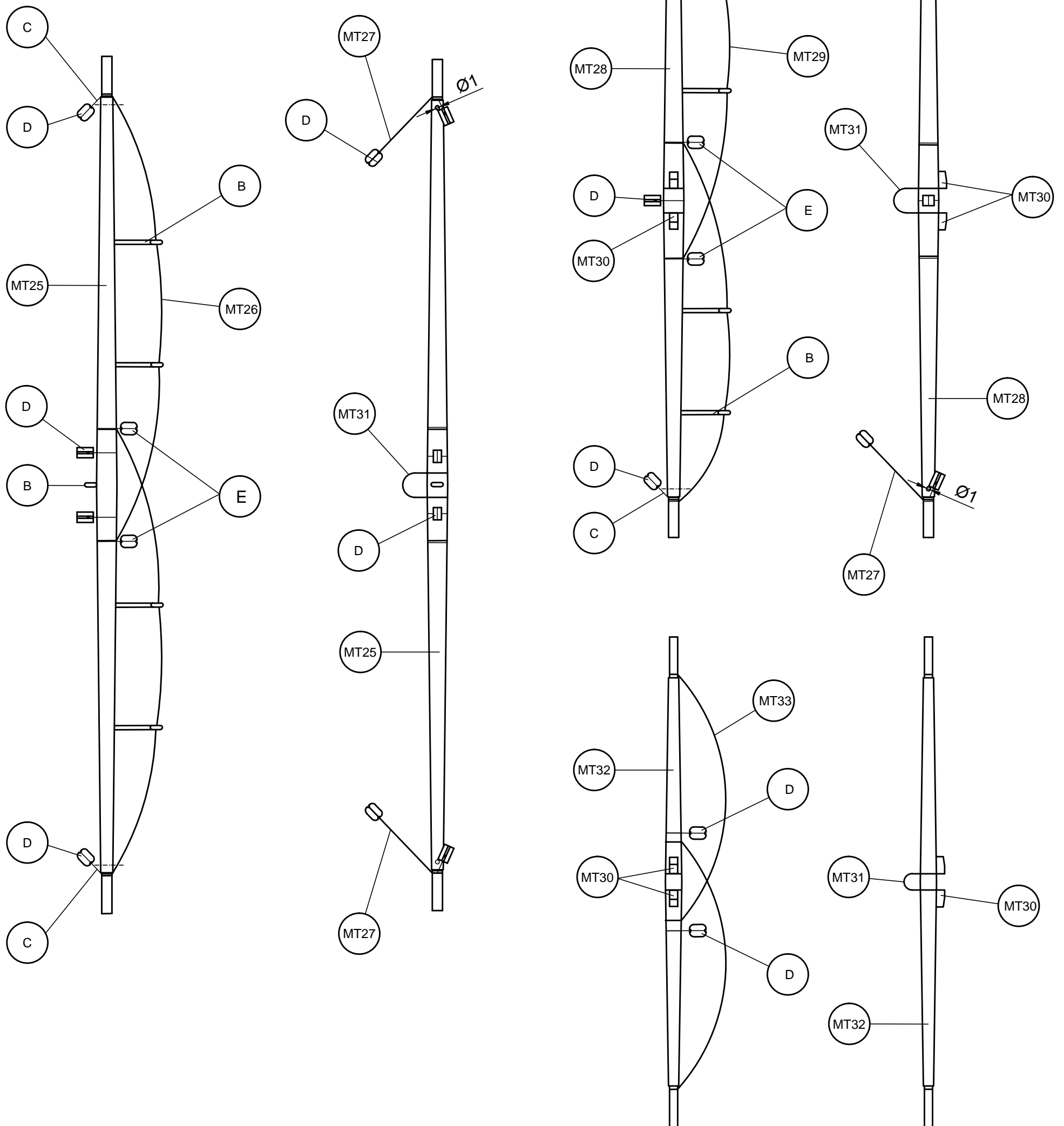

Scale 1/1

MT25	ø5x210	Tilo / Lime wood / Tilleul / Linde / Tiglio	MT32	ø4x120	Tilo / Lime wood / Tilleul / Linde / Tiglio
MT26	ø0,50x150	Hilo marrón / Brown thread / Fil brun / braunes Baumwollfaden / Filo marrone	MT33	ø0,50x110	Hilo marrón / Brown thread / Fil brun / braunes Baumwollfaden / Filo marrone
MT27	ø0,50x75	Hilo marrón / Brown thread / Fil brun / braunes Baumwollfaden / Filo marrone	B	15	Latón / Brass / Laiton / Messing / Ottone
MT28	ø5x165	Tilo / Lime wood / Tilleul / Linde / Tiglio	C	ø0,15x100	Hilo crudo / Raw thread / Fil brut / Rohes Baumwollfaden / Filo crudo
MT29	ø0,50x125	Hilo marrón / Brown thread / Fil brun / braunes Baumwollfaden / Filo marrone	D	4	Composite / Composite / Composite / Composite / Composite
MT30	2x2x4	Tilo / Lime wood / Tilleul / Linde / Tiglio	E	4	Composite / Composite / Composite / Composite / Composite
MT31	ø0,50x75	Hilo marrón / Brown thread / Fil brun / braunes Baumwollfaden / Filo marrone			

# Essex

Palo trinquete / Fore mast / Mât de misaine  
Fockmast / Albero trinchetto

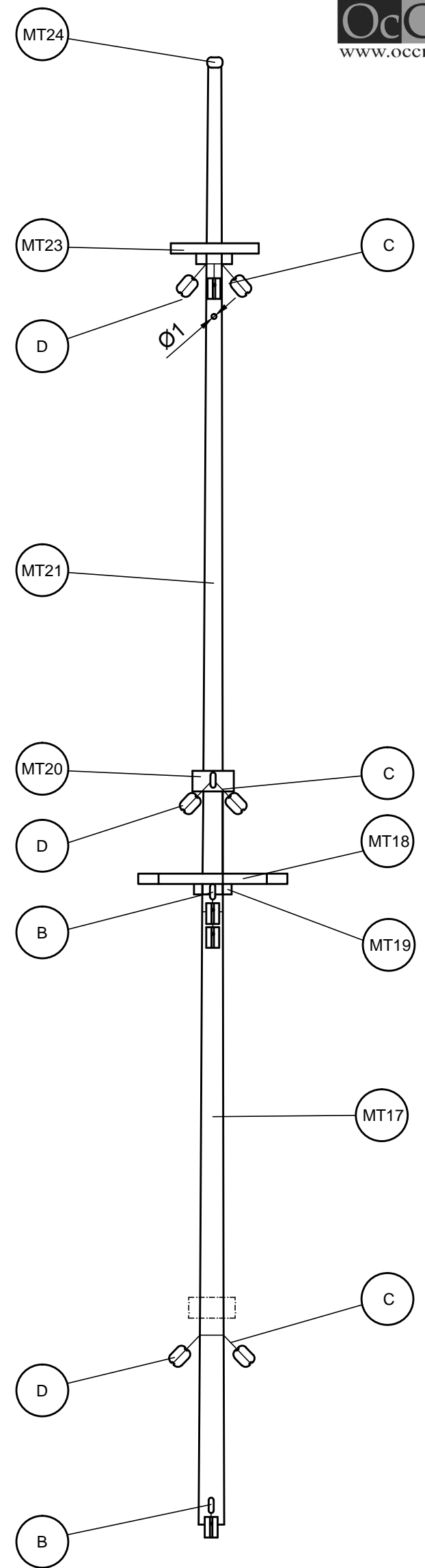
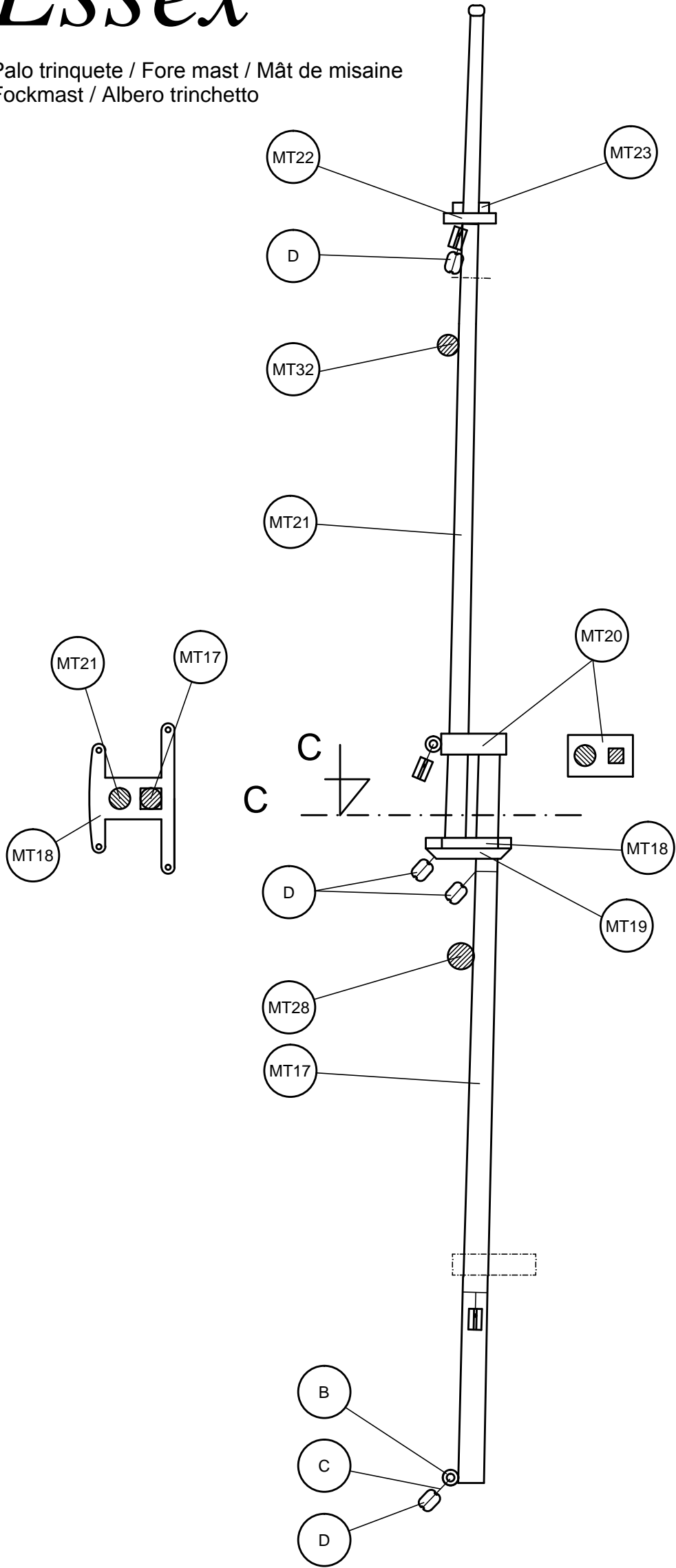

Scale 1/1

MT17	ø5x144	Tilo / Lime wood / Tilleul / Linde / Tiglio	MT23	2x2x16	Tilo / Lime wood / Tilleul / Linde / Tiglio
MT18	Precortado / Precut / Prédécoupé / Vorgeschnitten/ Pretagliato	Tablero / Plywood / Planche / Sperrholz / Tavola	MT24	ø3	Cristal / Crystal / Crystal / Kristall / Cristallo
MT19	2x2x17	Tilo / Lime wood / Tilleul / Linde / Tiglio	B	15	Latón / Brass / Laiton / Messing / Ottone
MT20	Precortado / Precut / Prédécoupé / Vorgeschnitten/ Pretagliato	Tablero / Plywood / Planche / Sperrholz / Tavola	C	ø0,15x100	Hilo crudo / Raw thread / Fil brut / Rohes Baumwollfaden / Filo crudo
MT21	ø4x162	Tilo / Lime wood / Tilleul / Linde / Tiglio	D	4	Composite / Composite / Composite / Composite / Composite
MT22	2x2x10	Tilo / Lime wood / Tilleul / Linde / Tiglio			

Palo mayor / Main mast  
Grand mât / Hauptmast  
Albero maestro

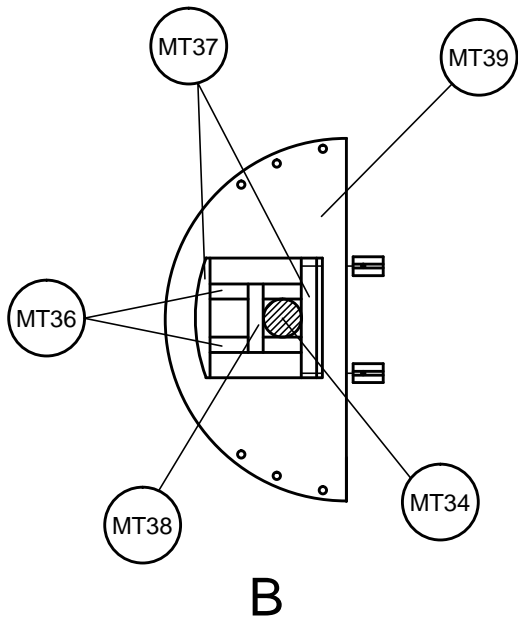
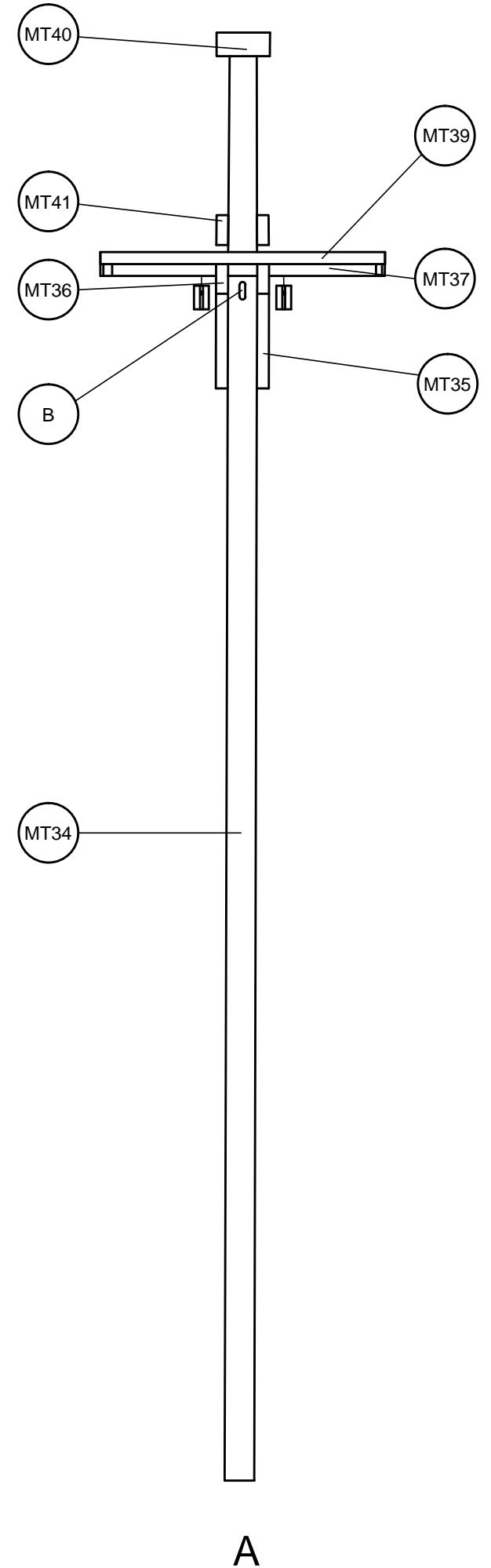
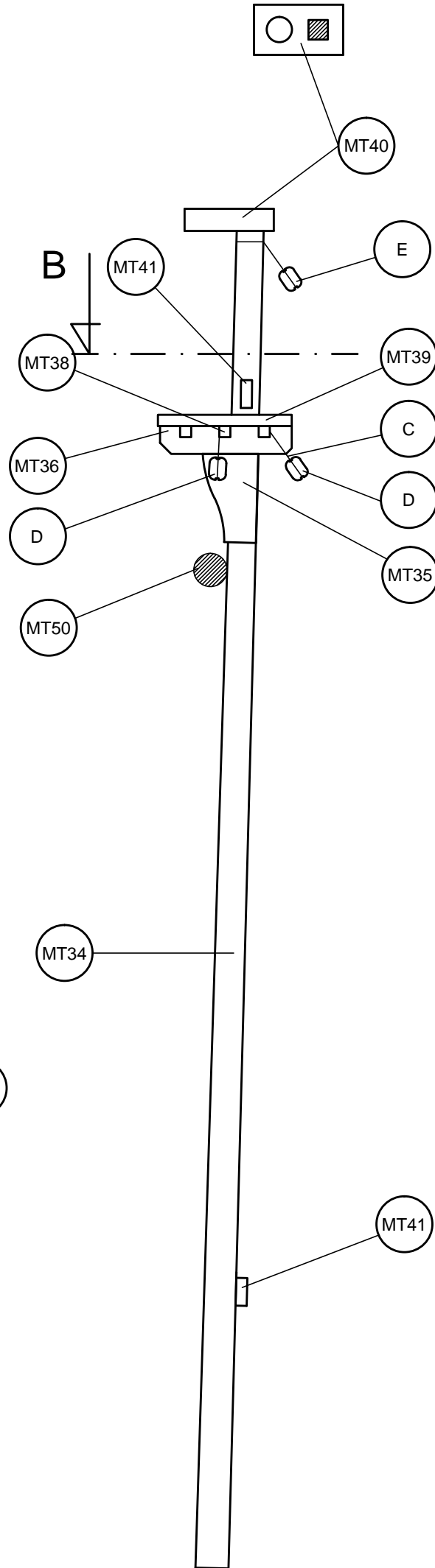
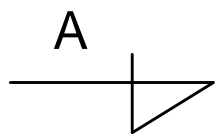
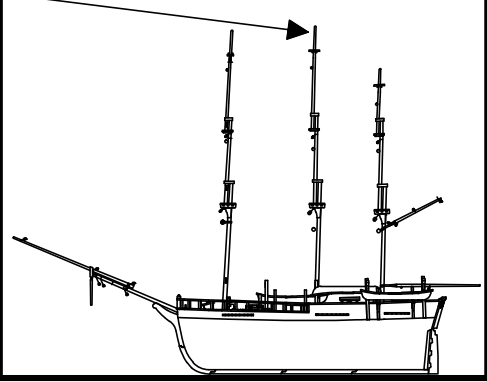

Scale 1/1

MT34	ø6x244	Tilo / Lime wood / Tilleul / Linde / Tiglio	MT40	Precortado / Precut / Prédécoupé / Vorgeschnitten / Pretagliato	Tablero / Plywood / Planche / Sperrholz / Tavola
MT35	Precortado / Precut / Prédécoupé / Vorgeschnitten / Pretagliato	Tablero / Plywood / Planche / Sperrholz / Tavola	MT41	2x2x5	Tilo / Lime wood / Tilleul / Linde / Tiglio
MT36	Precortado / Precut / Prédécoupé / Vorgeschnitten / Pretagliato	Tablero / Plywood / Planche / Sperrholz / Tavola	B	15	Latón / Brass / Laiton / Messing / Ottone
MT37	2x2x47	Tilo / Lime wood / Tilleul / Linde / Tiglio	C	ø0,15x100	Hilo crudo / Raw thread / Fil brut / Rohes Baumwollfaden / Filo crudo
MT38	2x2x9	Tilo / Lime wood / Tilleul / Linde / Tiglio	D	4	Composite / Composite / Composite / Composite / Composite
MT39	Precortado / Precut / Prédécoupé / Vorgeschnitten / Pretagliato	Tablero / Plywood / Planche / Sperrholz / Tavola	E	4	Composite / Composite / Composite / Composite / Composite

# Essex

Palo mayor / Main mast / Grand mât  
Hauptmast / Albero maestro

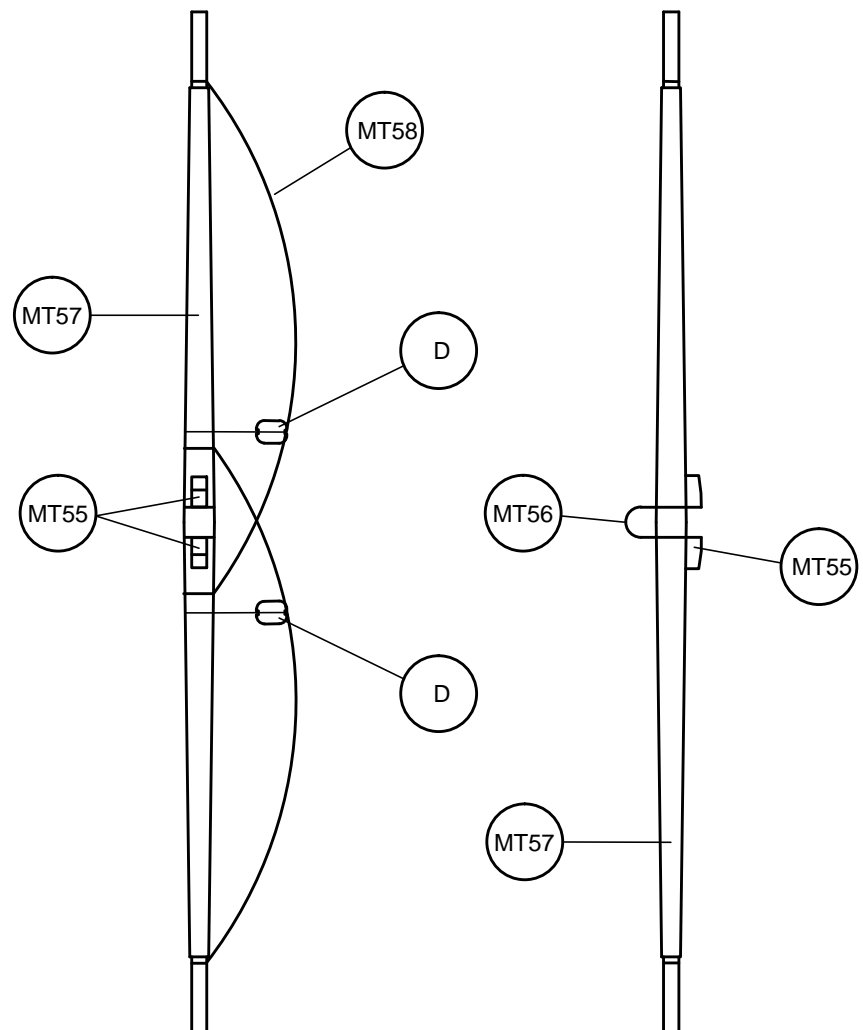
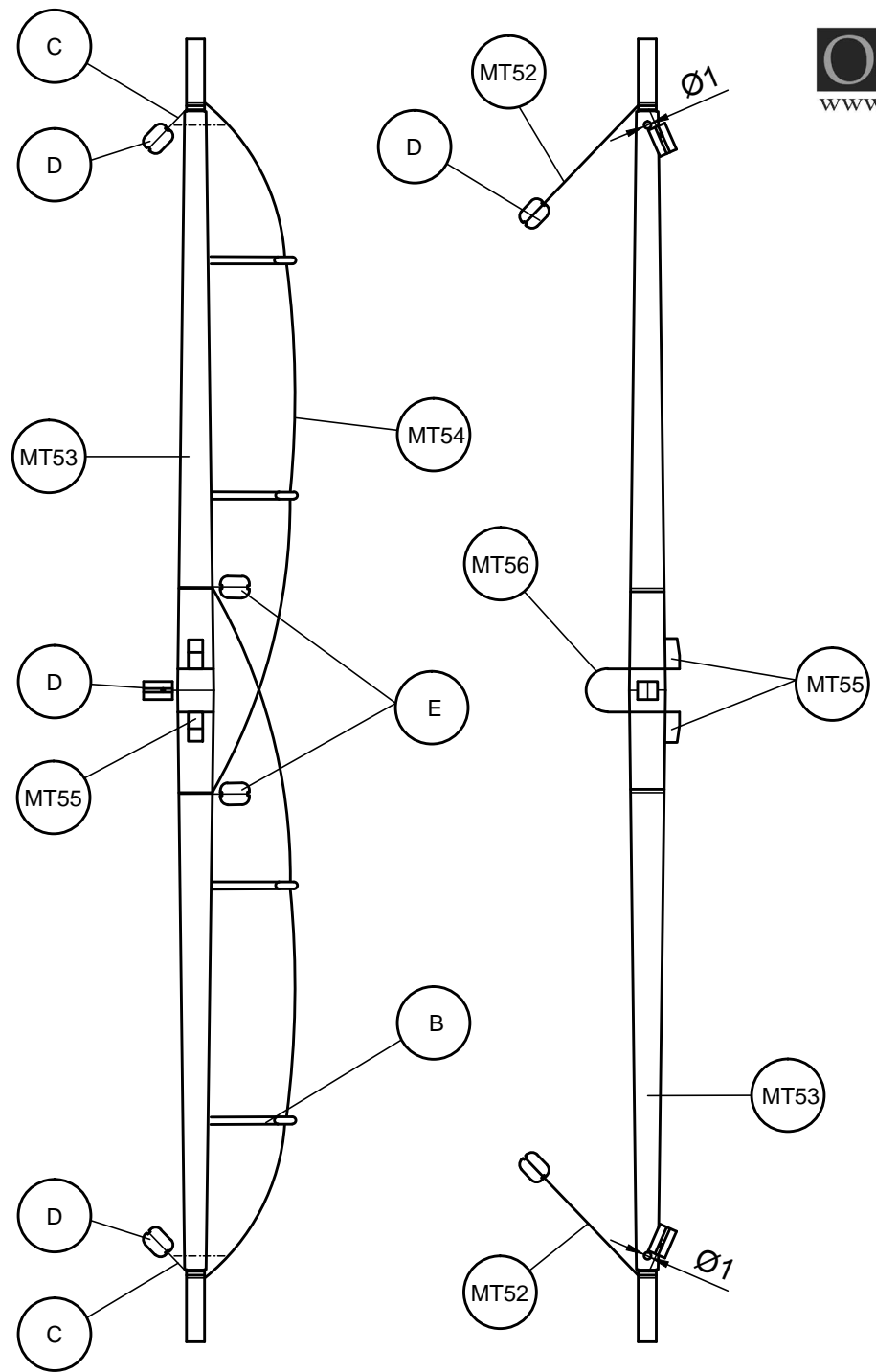
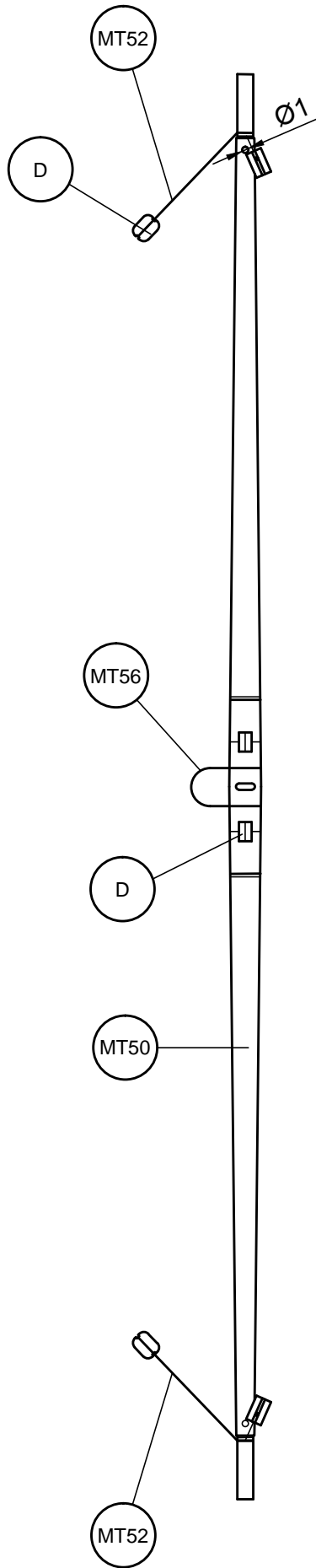
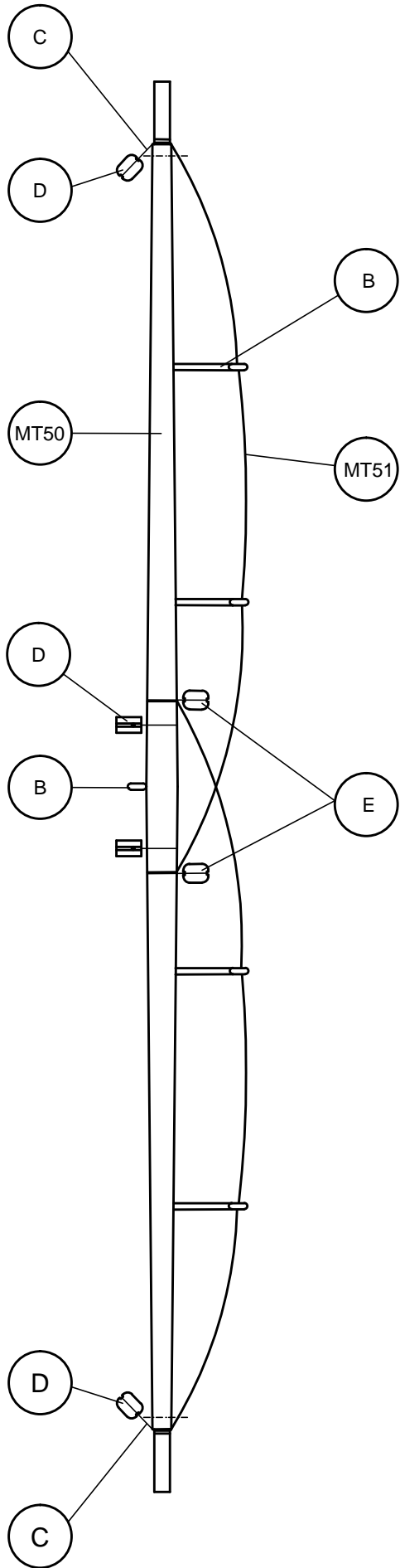

Scale 1/1

MT50	ø5x225	Tilo / Lime wood / Tilleul / Linde / Tiglio	MT57	ø4x135	Tilo / Lime wood / Tilleul / Linde / Tiglio
MT51	ø0,50x175	Hilo marrón / Brown thread / Fil brun / braunes Baumwollfaden / Filo marrone	MT58	ø0,50x110	Hilo marrón / Brown thread / Fil brun / braunes Baumwollfaden / Filo marrone
MT52	ø0,50x100	Hilo marrón / Brown thread / Fil brun / braunes Baumwollfaden / Filo marrone	B	15	Latón / Brass / Laiton / Messing / Ottone
MT53	ø5x180	Tilo / Lime wood / Tilleul / Linde / Tiglio	C	ø0,15x100	Hilo crudo / Raw thread / Fil brut / Rohes Baumwollfaden / Filo crudo
MT54	ø0,50x145	Hilo marrón / Brown thread / Fil brun / braunes Baumwollfaden / Filo marrone	D	4	Composite / Composite / Composite / Composite / Composite
MT55	2x2x4	Tilo / Lime wood / Tilleul / Linde / Tiglio	E	4	Composite / Composite / Composite / Composite / Composite
MT56	ø0,50x100	Hilo marrón / Brown thread / Fil brun / braunes Baumwollfaden / Filo marrone			

# Essex

Palo mayor / Main mast / Grand mât  
Hauptmast / Albero maestro

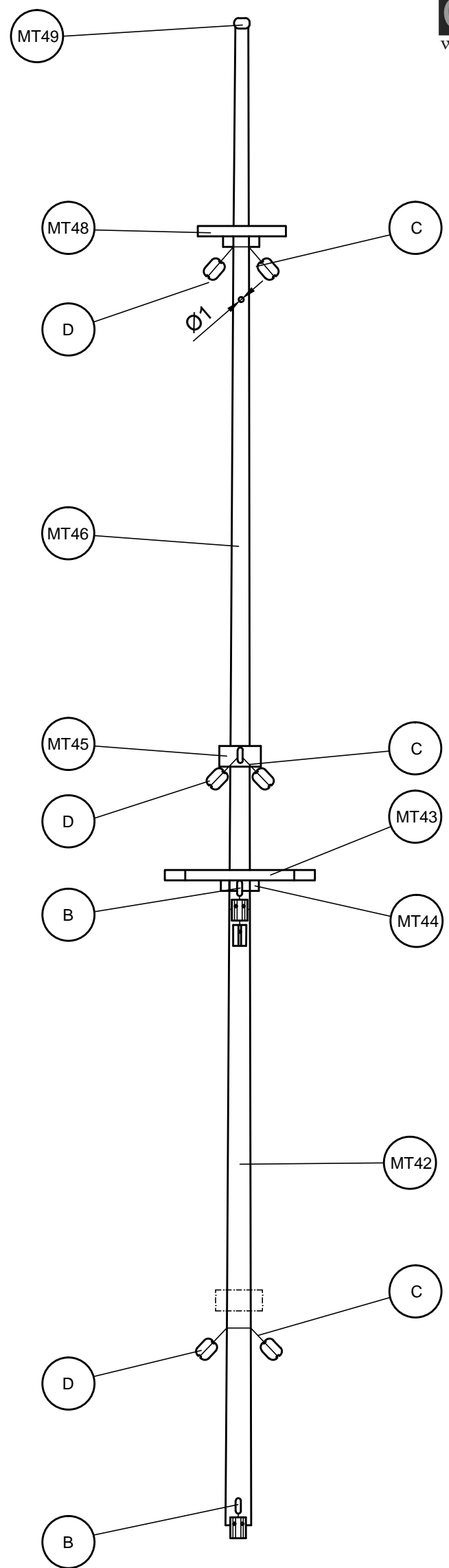
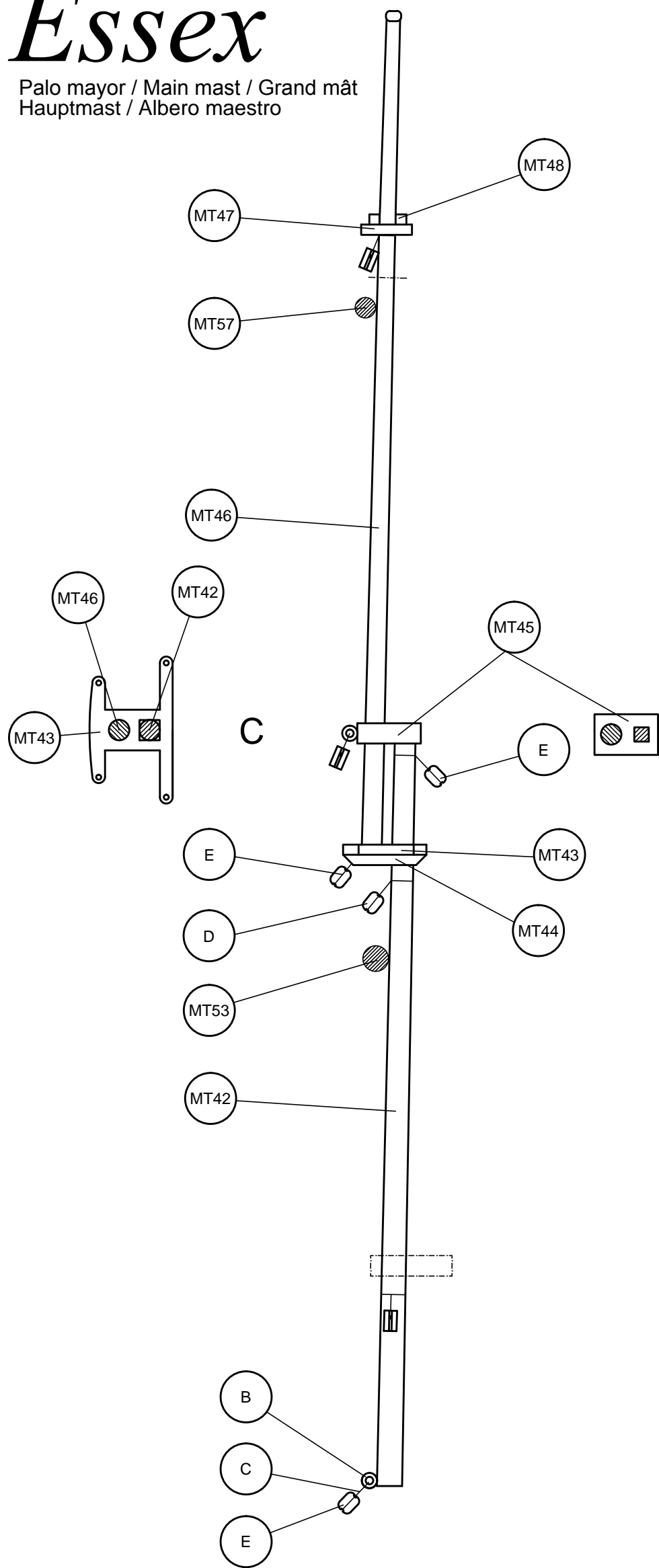

Scale 1/1

MT42	ø5x150	Ramin / Ramin / Ramin / Ramin / Ramin	MT48	2x2x17	Ramin / Ramin / Ramin / Ramin / Ramin
MT43	Precortado / Precut / Prédécoupé / Vorgeschnitten/ Pretagliato	Tablero / Plywood / Planche / Sperrholz / Tavola	MT49	ø3	Cristal / Crystal / Crystal / Kristall / Cristallo
MT44	2x2x17	Ramin / Ramin / Ramin / Ramin / Ramin	B	15	Latón / Brass / Laiton / Messing / Ottone
MT45	Precortado / Precut / Prédécoupé / Vorgeschnitten/ Pretagliato	Tablero / Plywood / Planche / Sperrholz / Tavola	C	ø0,15x100	Hilo crudo / Raw thread / Fil brut / Rohes Baumwollfaden / Filo crudo
MT46	ø4x166	Ramin / Ramin / Ramin / Ramin / Ramin	D	4	Composite / Composite / Composite / Composite / Composite
MT47	2x2x10	Ramin / Ramin / Ramin / Ramin / Ramin	E	4	Composite / Composite / Composite / Composite / Composite



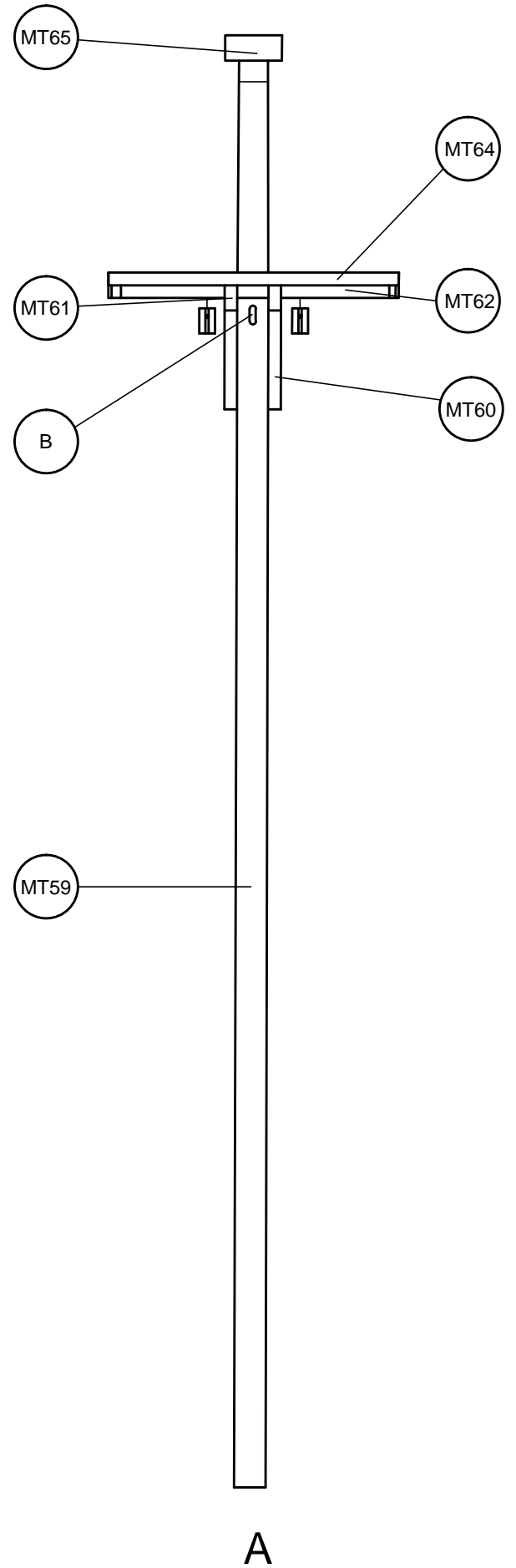
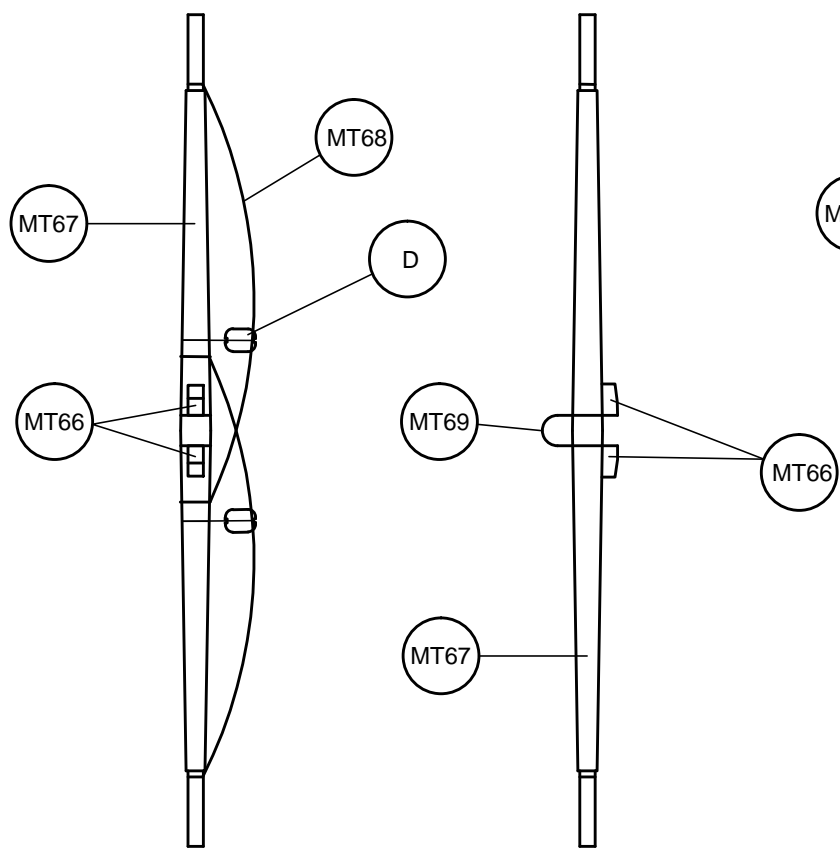
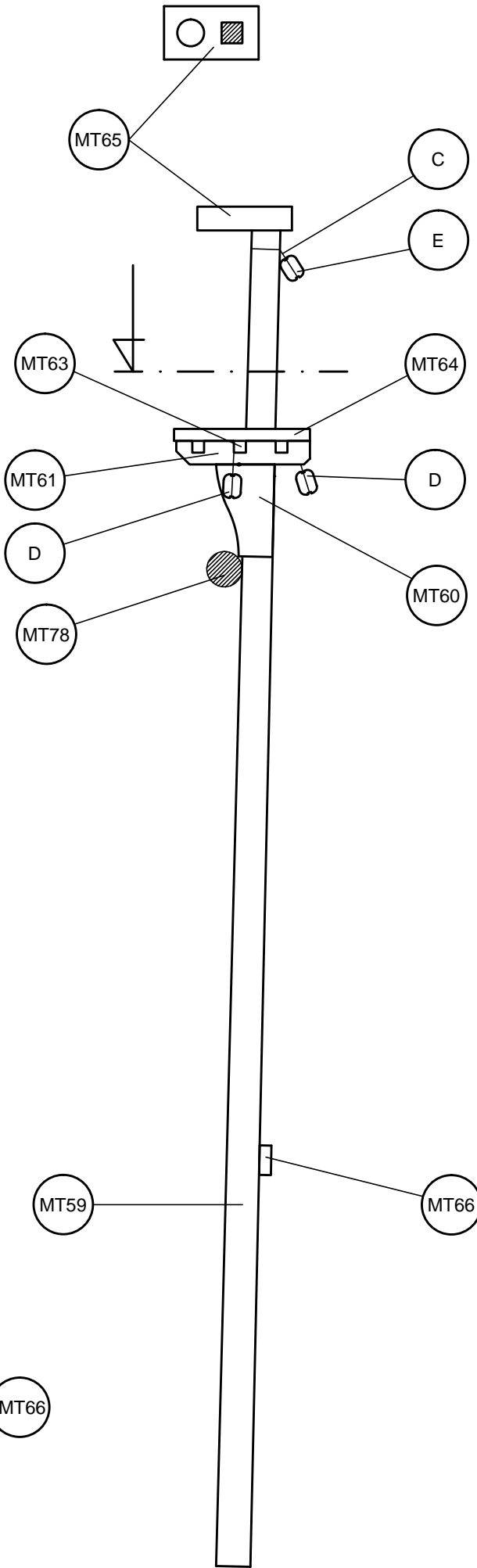
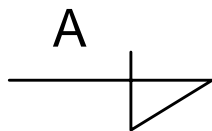
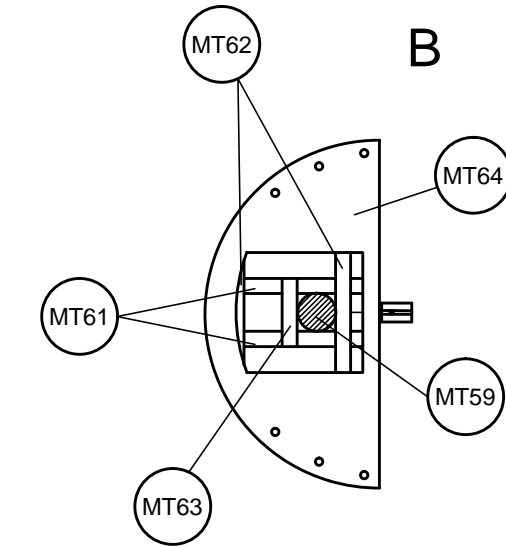
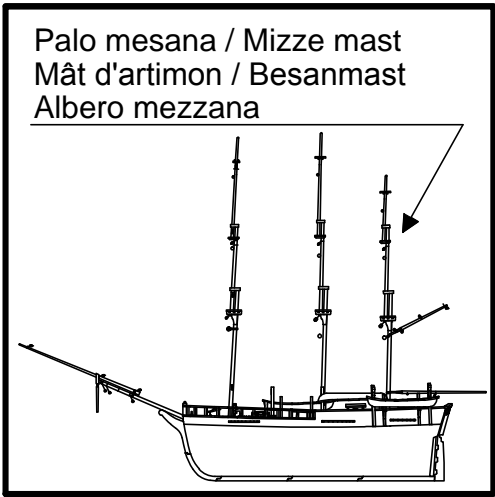

Scale 1/1

MT59	ø6x230	Ramin / Ramin / Ramin / Ramin / Ramin	MT67	ø4x110	Ramin / Ramin / Ramin / Ramin / Ramin
MT60	Precortado / Precut / Prédécoupé / Vorgeschnitten / Pretagliato	Tablero / Plywood / Planche / Sperrholz / Tavola	MT68	ø0,50x140	Hilo marrón / Brown thread / Fil brun / braunes Baumwollfaden / Filo marrone
MT61	Precortado / Precut / Prédécoupé / Vorgeschnitten / Pretagliato	Tablero / Plywood / Planche / Sperrholz / Tavola	MT69	ø0,50x100	Hilo marrón / Brown thread / Fil brun / braunes Baumwollfaden / Filo marrone
MT62	2x2x45	Ramin / Ramin / Ramin / Ramin / Ramin	B	15	Latón / Brass / Laiton / Messing / Ottone
MT63	2x2x9	Ramin / Ramin / Ramin / Ramin / Ramin	C	ø0,15x100	Hilo crudo / Raw thread / Fil brut / Rohes Baumwollfaden / Filo crudo
MT64	Precortado / Precut / Prédécoupé / Vorgeschnitten / Pretagliato	Tablero / Plywood / Planche / Sperrholz / Tavola	D	4	Composite / Composite / Composite / Composite / Composite
MT65	Precortado / Precut / Prédécoupé / Vorgeschnitten / Pretagliato	Tablero / Plywood / Planche / Sperrholz / Tavola	E	4	Composite / Composite / Composite / Composite / Composite
MT66	2x2x5	Ramin / Ramin / Ramin / Ramin / Ramin			

# Essex

Palo mesana / Mizze mast  
Mât d'artimon / Besanmast  
Albero mezzana

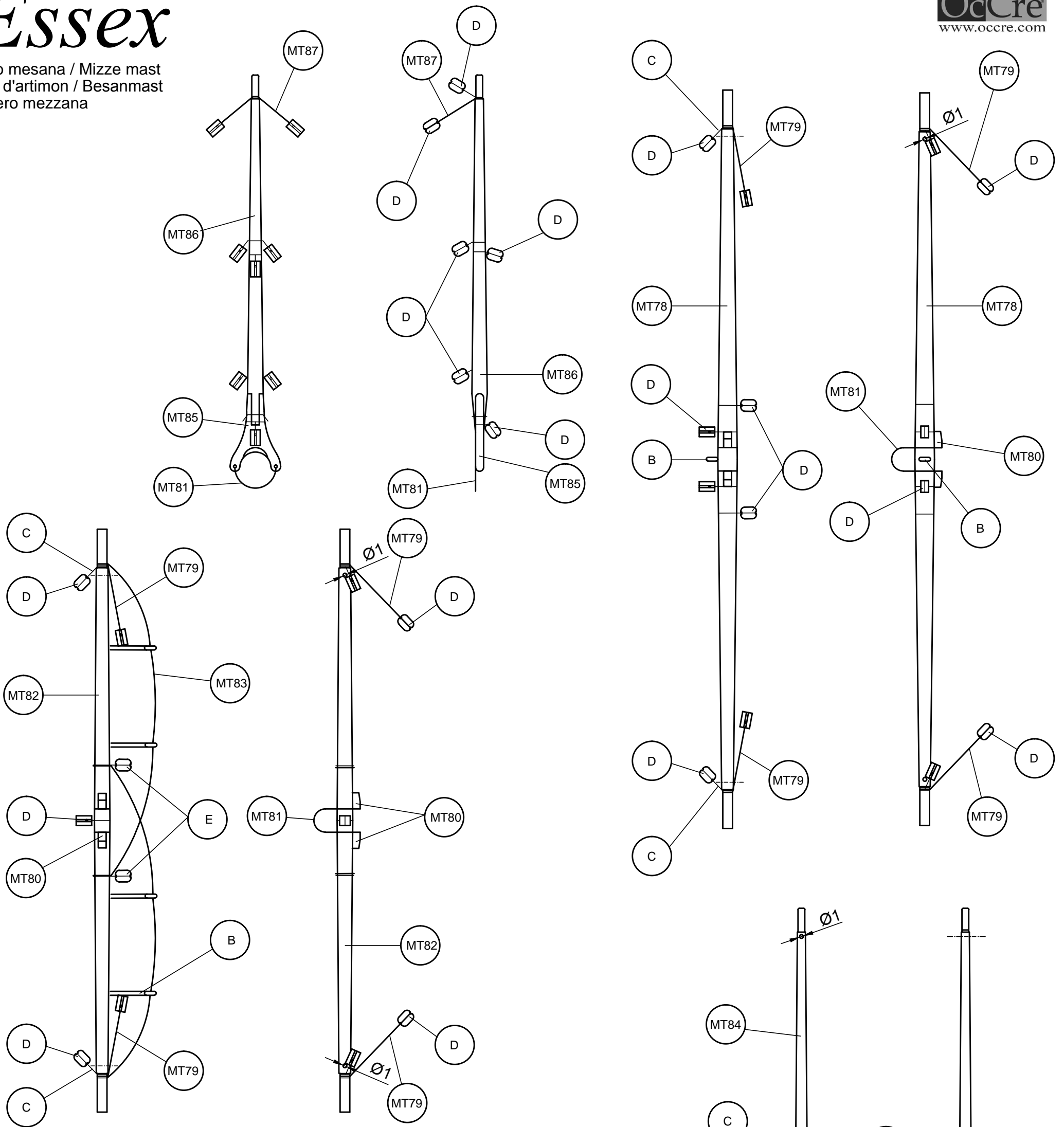

MT78	ø5x190	Tilo / Lime wood / Tilleul / Linde / Tiglio
MT79	ø0,50x100	Hilo marrón / Brown thread / Fil brun / braunes Baumwollfaden / Filo marrone
MT80	2x2x4	Tilo / Lime wood / Tilleul / Linde / Tiglio
MT81	ø0,50x100	Hilo marrón / Brown thread / Fil brun / braunes Baumwollfaden / Filo marrone
MT82	ø4x150	Tilo / Lime wood / Tilleul / Linde / Tiglio
MT83	ø0,50x165	Hilo marrón / Brown thread / Fil brun / braunes Baumwollfaden / Filo marrone
MT84	ø4x140	Tilo / Lime wood / Tilleul / Linde / Tiglio
MT85	Preformado / Preformed/ Préformé / Vorgeformt / Preformato	Metal / Metal / Metal / Metall / Metallo
MT86	ø4x90	Tilo / Lime wood / Tilleul / Linde / Tiglio
MT87	ø0,50x100	Hilo marrón / Brown thread / Fil brun / braunes Baumwollfaden / Filo marrone
B	15	Latón / Brass / Laiton / Messing / Ottone
C	ø0,15x100	Hilo crudo / Raw thread / Fil brut / Rohes Baumwollfaden / Filo crudo
D	4	Composite / Composite / Composite / Composite / Composite
E	4	Composite / Composite / Composite / Composite / Composite

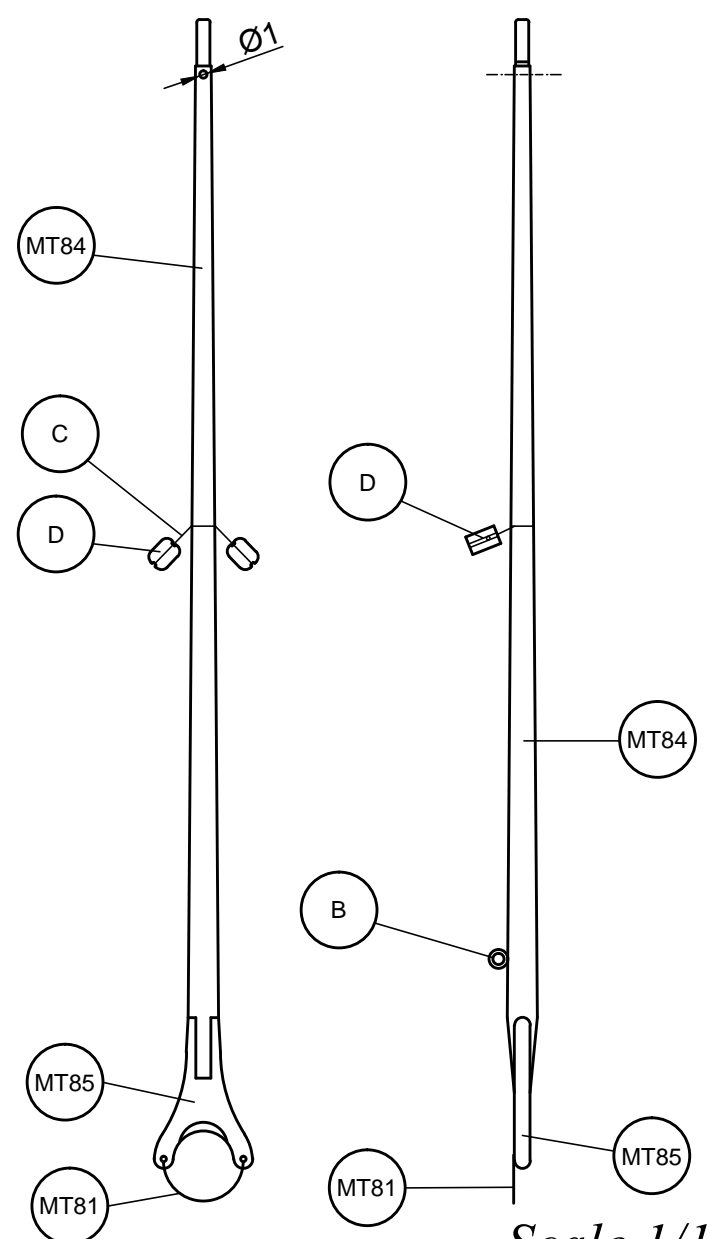

Scale 1/1

Palo mesana / Mizze mast  
Mât d'artimon / Besanmast  
Albero mezzana

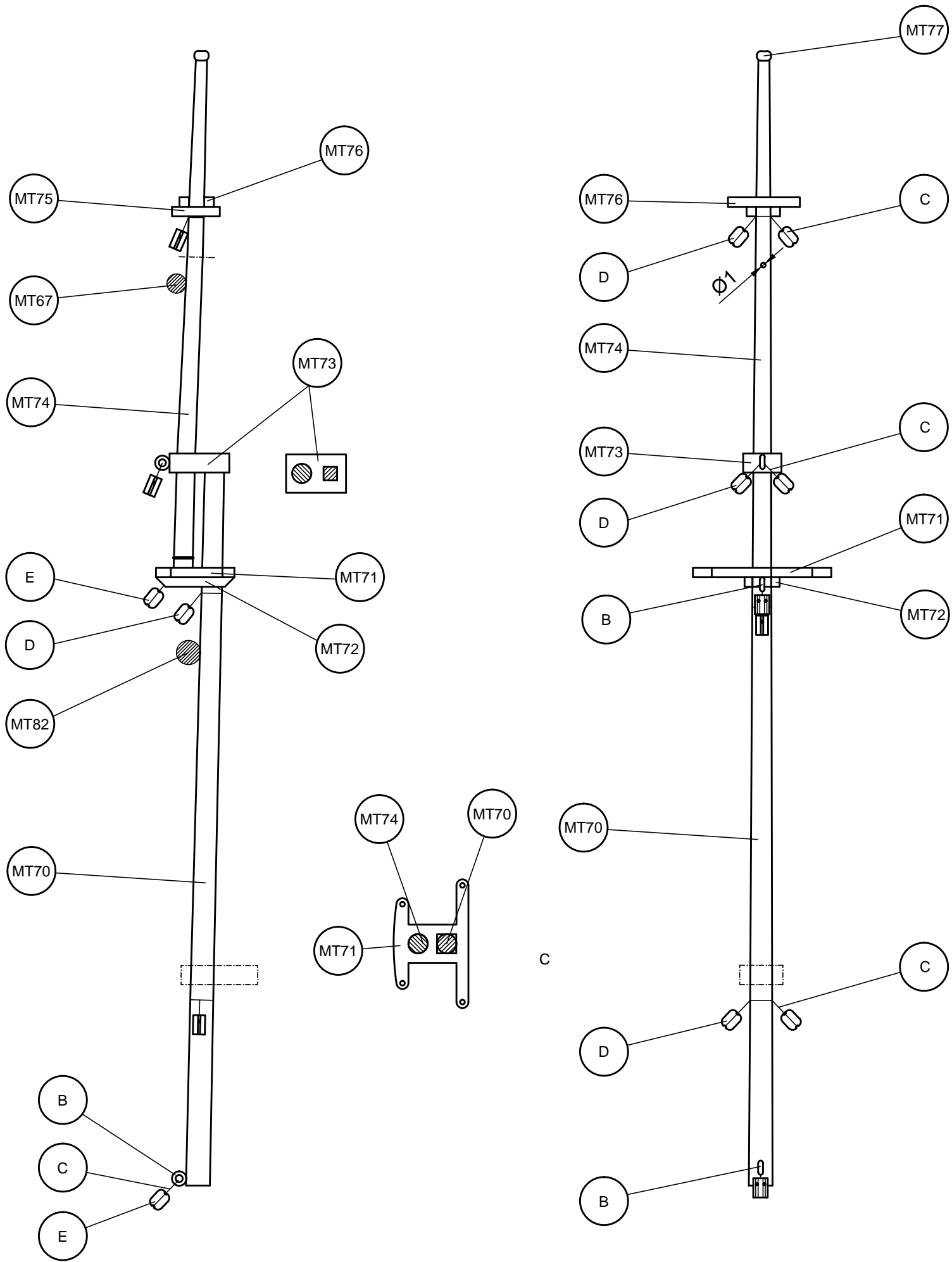

Scale 1/1

MT70	ø5x153	Tilo / Lime wood / Tilleul / Linde / Tiglio	MT76	2x2x15	Tilo / Lime wood / Tilleul / Linde / Tiglio
MT71	Precortado / Precut / Prédécoupé / Vorgeschnitten/ Pretagliato	Tablero / Plywood / Planche / Sperrholz / Tavola	MT77	ø3	Cristal / Crystal / Crystal / Kristall / Cristallo
MT72	2x2x16	Tilo / Lime wood / Tilleul / Linde / Tiglio	B	15	Latón / Brass / Laiton / Messing / Ottone
MT73	Precortado / Precut / Prédécoupé / Vorgeschnitten/ Pretagliato	Tablero / Plywood / Planche / Sperrholz / Tavola	C	ø0,15x100	Hilo crudo / Raw thread / Fil brut / Rohes Baumwollfaden / Filo crudo
MT74	ø4x110	Tilo / Lime wood / Tilleul / Linde / Tiglio	D	4	Composite / Composite / Composite / Composite / Composite
MT75	2x2x10	Tilo / Lime wood / Tilleul / Linde / Tiglio	E	4	Composite / Composite / Composite / Composite / Composite

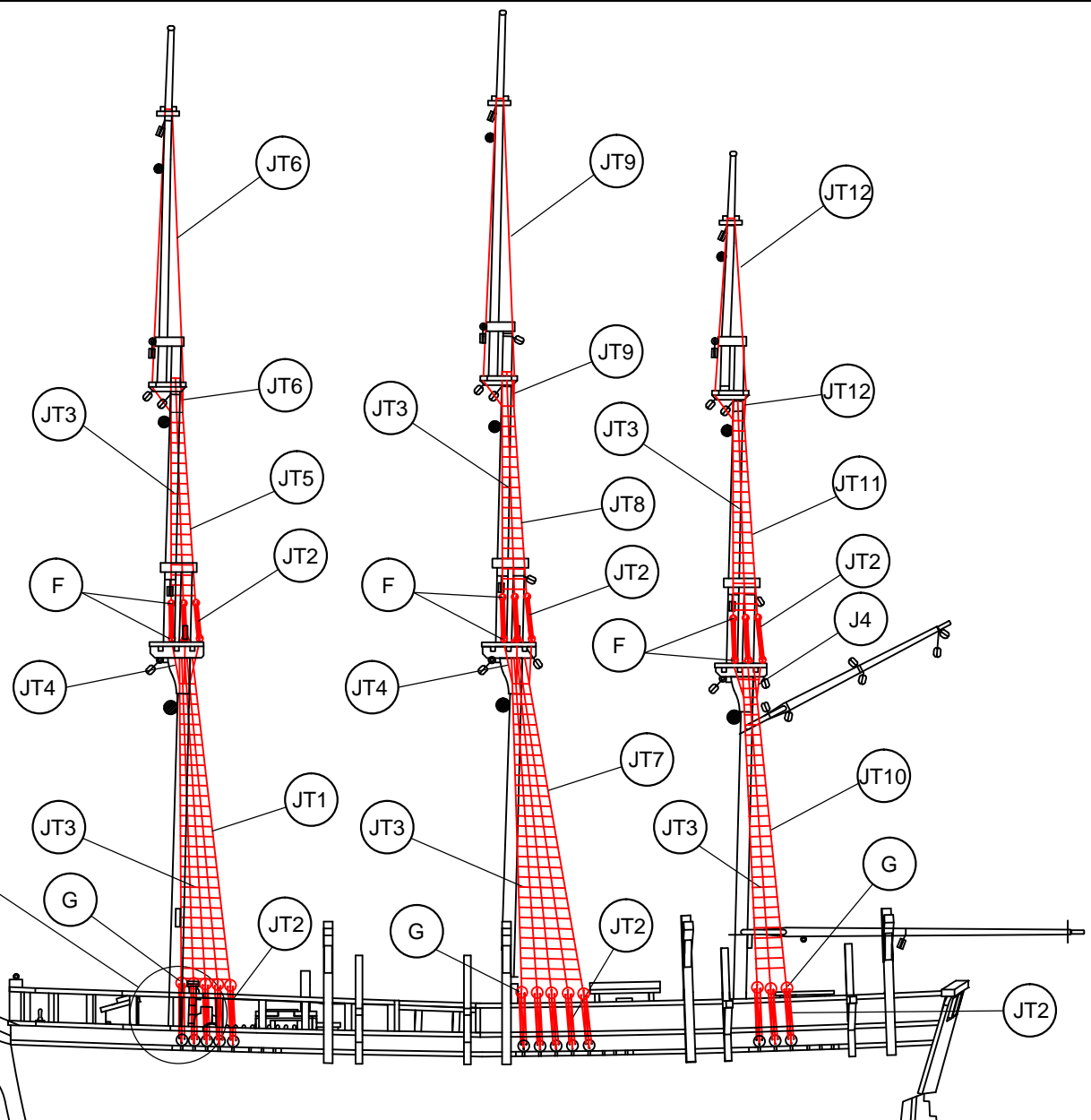
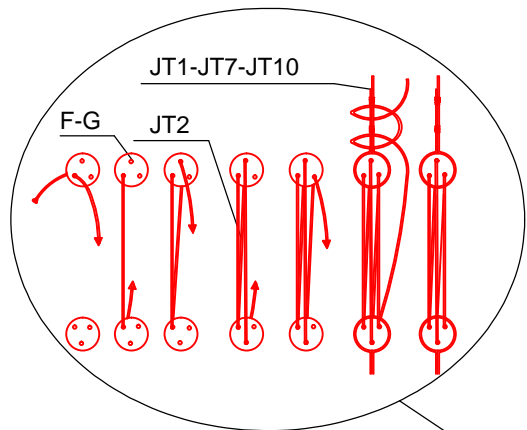

JT1	∅0,50x450	Hilo marrón / Brown thread / Fil brun / braunes Baumwollfaden / Filo marrone	JT8	∅0,50x350	Hilo marrón / Brown thread / Fil brun / braunes Baumwollfaden / Filo marrone
JT2	∅0,15x175	Hilo crudo / Raw thread / Fil brut / Rohes Baumwollfaden / Filo crudo	JT9	∅0,50x400	Hilo marrón / Brown thread / Fil brun / braunes Baumwollfaden / Filo marrone
JT3	∅0,15x100	Hilo marrón / Brown thread / Fil brun / braunes Baumwollfaden / Filo marrone	JT10	∅0,50x425	Hilo marrón / Brown thread / Fil brun / braunes Baumwollfaden / Filo marrone
JT4	∅0,50x100	Hilo marrón / Brown thread / Fil brun / braunes Baumwollfaden / Filo marrone	JT11	∅0,50x290	Hilo marrón / Brown thread / Fil brun / braunes Baumwollfaden / Filo marrone
JT5	∅0,50x290	Hilo marrón / Brown thread / Fil brun / braunes Baumwollfaden / Filo marrone	JT12	∅0,50x320	Hilo marrón / Brown thread / Fil brun / braunes Baumwollfaden / Filo marrone
JT6	∅0,50x375	Hilo marrón / Brown thread / Fil brun / braunes Baumwollfaden / Filo marrone	F	∅4	Composite / Composite / Composite / Composite / Composite
JT7	∅0,50x485	Hilo marrón / Brown thread / Fil brun / braunes Baumwollfaden / Filo marrone	G	∅5	Composite / Composite / Composite / Composite / Composite

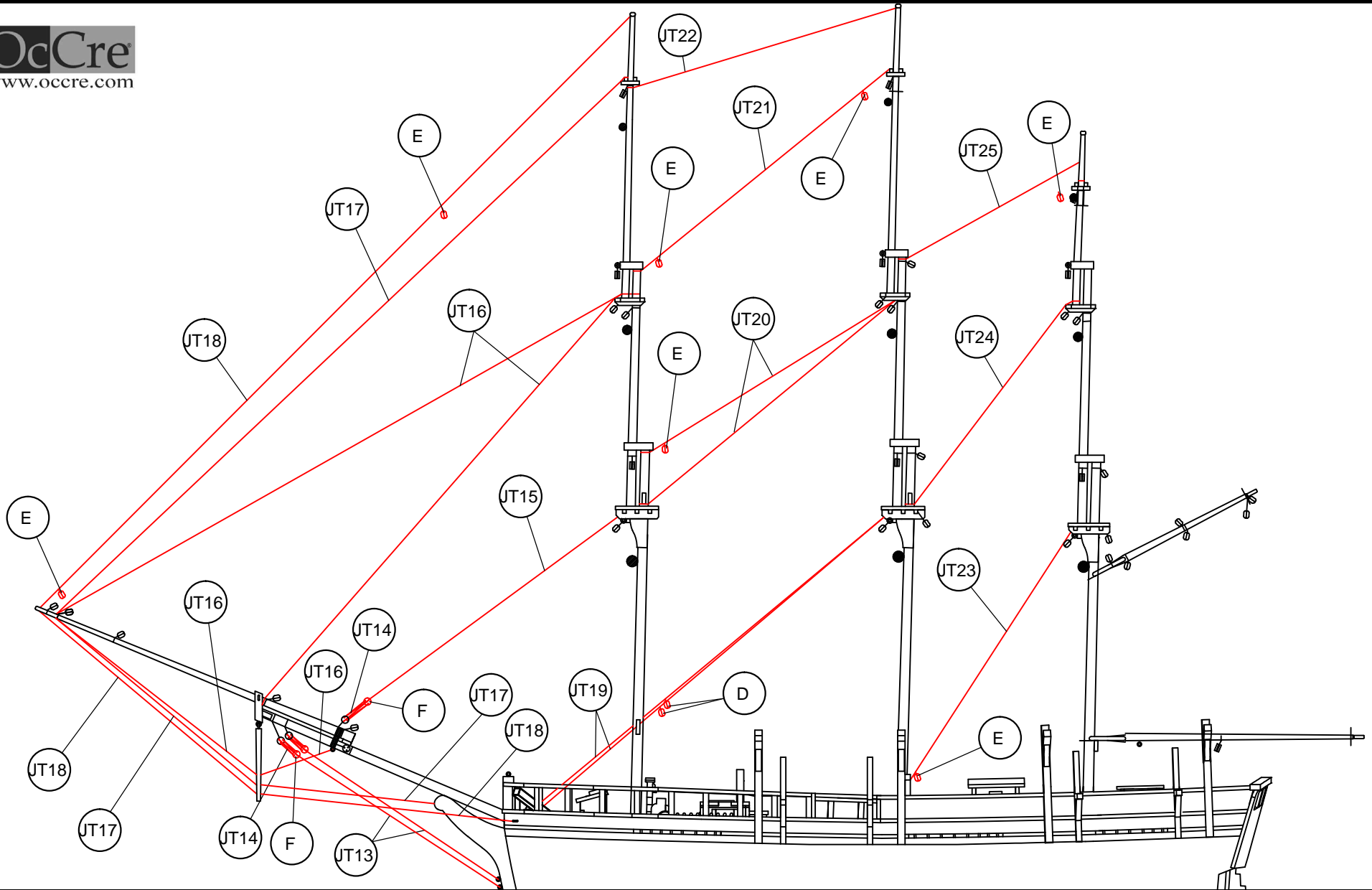

JT13	∅0,50x225	Hilo marrón / Brown thread / Fil brun / braunes Baumwollfaden / Filo marrone	JT21	∅0,50x320	Hilo marrón / Brown thread / Fil brun / braunes Baumwollfaden / Filo marrone
JT14	∅0,15x200	Hilo crudo / Raw thread / Fil brut / Rohes Baumwollfaden / Filo crudo	JT22	∅0,50x250	Hilo marrón / Brown thread / Fil brun / braunes Baumwollfaden / Filo marrone
JT15	∅0,50x300	Hilo marrón / Brown thread / Fil brun / braunes Baumwollfaden / Filo marrone	JT23	∅0,50x275	Hilo marrón / Brown thread / Fil brun / braunes Baumwollfaden / Filo marrone
JT16	∅0,50x710	Hilo marrón / Brown thread / Fil brun / braunes Baumwollfaden / Filo marrone	JT24	∅0,50x225	Hilo marrón / Brown thread / Fil brun / braunes Baumwollfaden / Filo marrone
JT17	∅0,50x900	Hilo marrón / Brown thread / Fil brun / braunes Baumwollfaden / Filo marrone	JT25	∅0,50x220	Hilo marrón / Brown thread / Fil brun / braunes Baumwollfaden / Filo marrone
JT18	∅0,50x950	Hilo marrón / Brown thread / Fil brun / braunes Baumwollfaden / Filo marrone	D	4	Composite / Composite / Composite / Composite / Composite
JT19	∅0,50x700	Hilo marrón / Brown thread / Fil brun / braunes Baumwollfaden / Filo marrone	E	4	Composite / Composite / Composite / Composite / Composite
JT20	∅0,50x500	Hilo marrón / Brown thread / Fil brun / braunes Baumwollfaden / Filo marrone	F	∅5	Composite / Composite / Composite / Composite / Composite

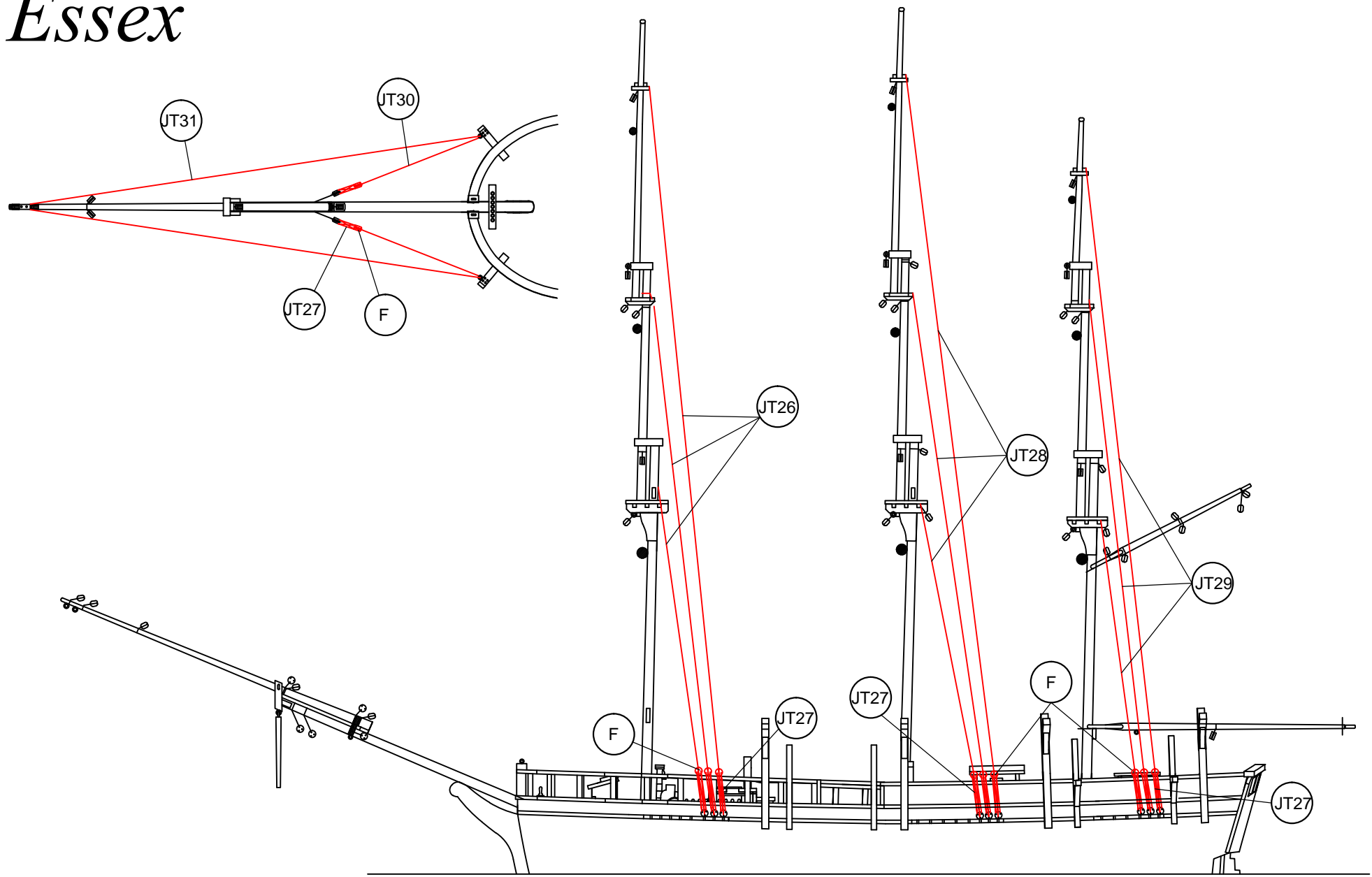

JT26	ø0,50x900	Hilo marrón / Brown thread / Fil brun / braunes Baumwollfaden / Filo marrone	JT30	ø0,50x185	Hilo marrón / Brown thread / Fil brun / braunes Baumwollfaden / Filo marrone
JT27	ø0,15x200	Hilo crudo / Raw thread / Fil brut / Rohes Baumwollfaden / Filo crudo	JT31	ø0,50x375	Hilo marrón / Brown thread / Fil brun / braunes Baumwollfaden / Filo marrone
JT28	ø0,50x985	Hilo marrón / Brown thread / Fil brun / braunes Baumwollfaden / Filo marrone	F	ø4	Composite / Composite / Composite / Composite / Composite
JT29	ø0,50x800	Hilo marrón / Brown thread / Fil brun / braunes Baumwollfaden / Filo marrone			

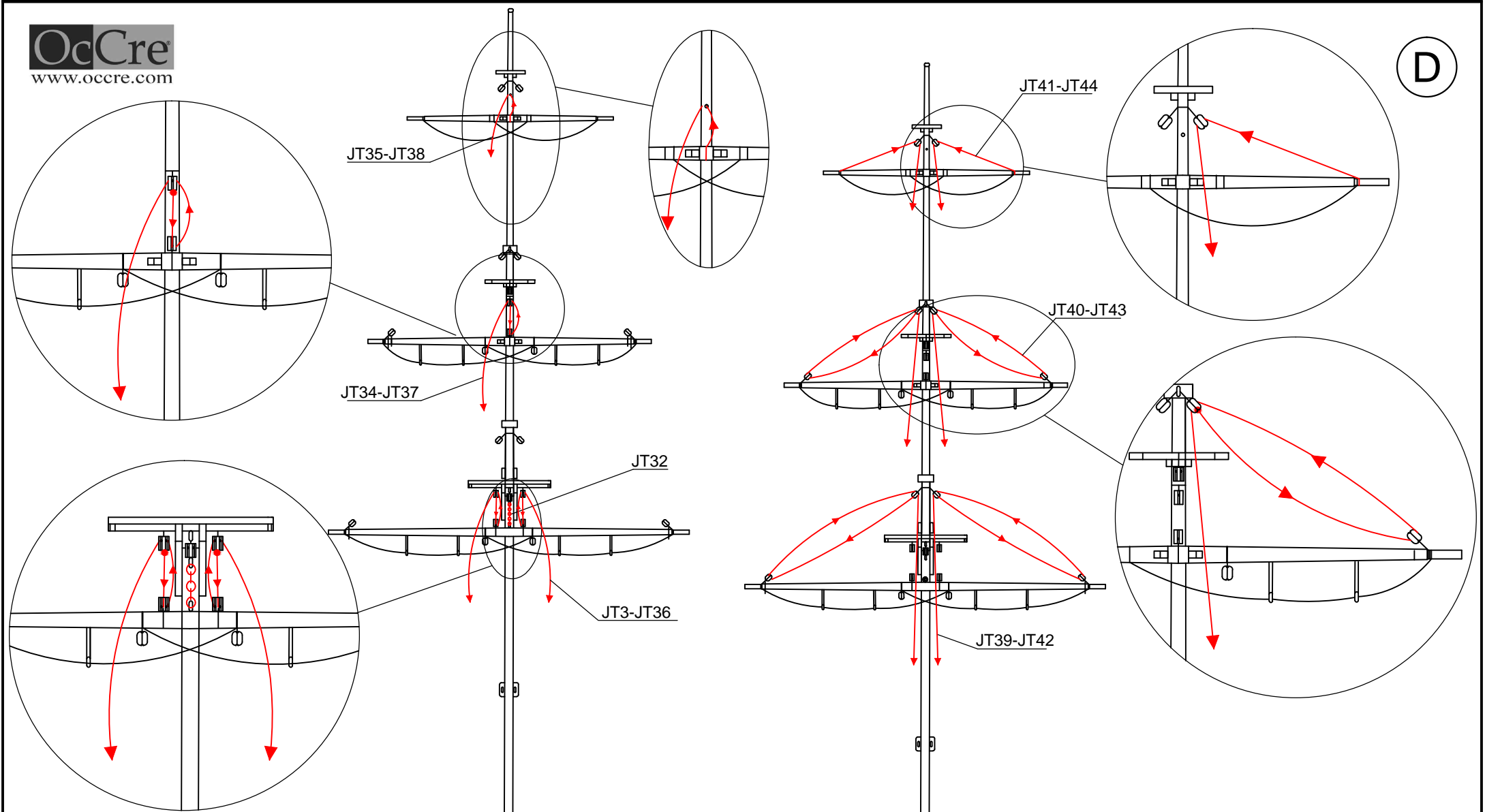

JT32	1x40	Latón / Brass / Laiton / Messing / Ottone	JT39	ø0,15x500	Hilo crudo / Raw thread / Fil brut / Rohes Baumwollfaden / Filo crudo
JT33	ø0,15x320	Hilo crudo / Raw thread / Fil brut / Rohes Baumwollfaden / Filo crudo	JT40	ø0,15x600	Hilo crudo / Raw thread / Fil brut / Rohes Baumwollfaden / Filo crudo
JT34	ø0,15x425	Hilo crudo / Raw thread / Fil brut / Rohes Baumwollfaden / Filo crudo	JT41	ø0,15x690	Hilo crudo / Raw thread / Fil brut / Rohes Baumwollfaden / Filo crudo
JT35	ø0,15x525	Hilo crudo / Raw thread / Fil brut / Rohes Baumwollfaden / Filo crudo	JT42	ø0,15x575	Hilo crudo / Raw thread / Fil brut / Rohes Baumwollfaden / Filo crudo
JT36	ø0,15x360	Hilo crudo / Raw thread / Fil brut / Rohes Baumwollfaden / Filo crudo	JT43	ø0,15x675	Hilo crudo / Raw thread / Fil brut / Rohes Baumwollfaden / Filo crudo
JT37	ø0,15x490	Hilo crudo / Raw thread / Fil brut / Rohes Baumwollfaden / Filo crudo	JT44	ø0,15x720	Hilo crudo / Raw thread / Fil brut / Rohes Baumwollfaden / Filo crudo
JT38	ø0,15x620	Hilo crudo / Raw thread / Fil brut / Rohes Baumwollfaden / Filo crudo			

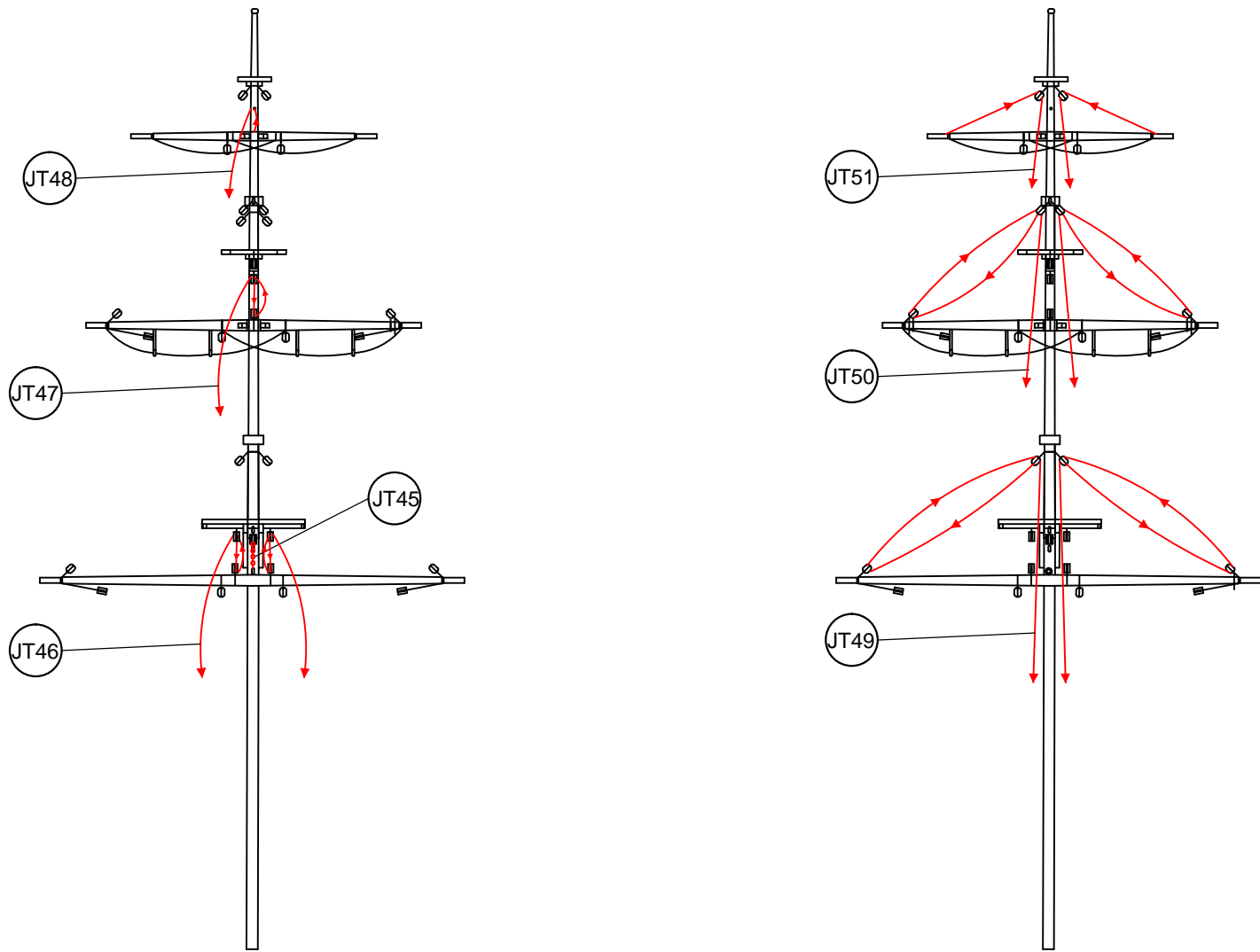

JT45	1x40	Latón / Brass / Laiton / Messing / Ottone	JT49	∅0,15x500	Hilo crudo / Raw thread / Fil brut / Rohes Baumwollfaden / Filo crudo
JT46	∅0,15x320	Hilo crudo / Raw thread / Fil brut / Rohes Baumwollfaden / Filo crudo	JT50	∅0,15x600	Hilo crudo / Raw thread / Fil brut / Rohes Baumwollfaden / Filo crudo
JT47	∅0,15x425	Hilo crudo / Raw thread / Fil brut / Rohes Baumwollfaden / Filo crudo	JT51	∅0,15x690	Hilo crudo / Raw thread / Fil brut / Rohes Baumwollfaden / Filo crudo
JT48	∅0,15x525	Hilo crudo / Raw thread / Fil brut / Rohes Baumwollfaden / Filo crudo			

Aparejo de velas / Sail rig / Gréement  
Segel takelage / Sartiamé da vela

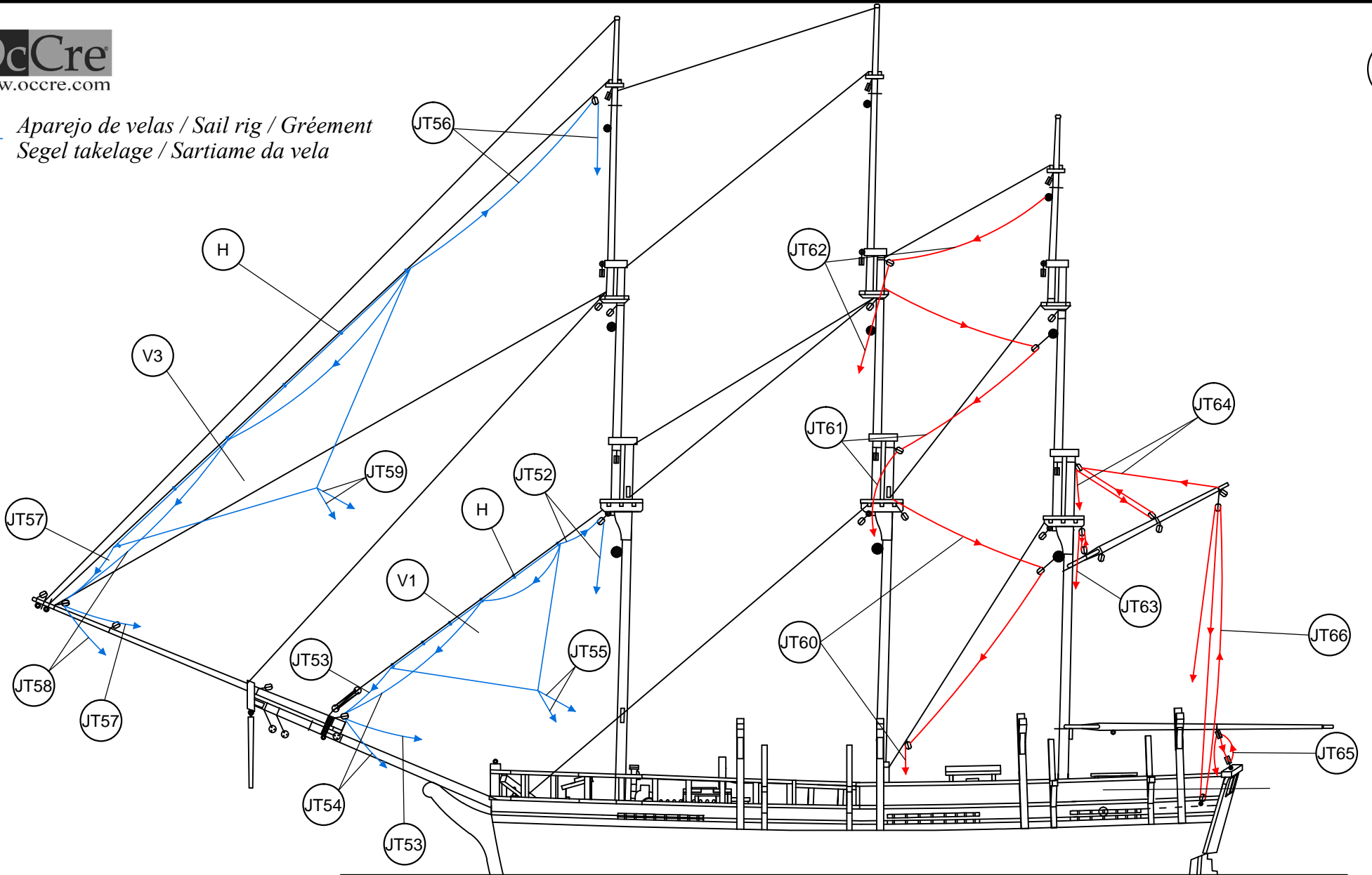

V1	Preformado / Preformed/ Préformé / Vorgeformt / Preformato	Tela / Cloth / Étoffe / Stoff / Tela	JT59	∅0,15x500	Hilo crudo / Raw thread / Fil brut / Rohes Baumwollfaden / Filo crudo
JT52	∅0,15x320	Hilo crudo / Raw thread / Fil brut / Rohes Baumwollfaden / Filo crudo	JT60	∅0,15x445	Hilo crudo / Raw thread / Fil brut / Rohes Baumwollfaden / Filo crudo
JT53	∅0,15x300	Hilo crudo / Raw thread / Fil brut / Rohes Baumwollfaden / Filo crudo	JT61	∅0,15x550	Hilo crudo / Raw thread / Fil brut / Rohes Baumwollfaden / Filo crudo
JT54	∅0,15x300	Hilo crudo / Raw thread / Fil brut / Rohes Baumwollfaden / Filo crudo	JT62	∅0,15x600	Hilo crudo / Raw thread / Fil brut / Rohes Baumwollfaden / Filo crudo
JT55	∅0,15x200	Hilo crudo / Raw thread / Fil brut / Rohes Baumwollfaden / Filo crudo	JT63	∅0,15x300	Hilo crudo / Raw thread / Fil brut / Rohes Baumwollfaden / Filo crudo
V3	Preformado / Preformed/ Préformé / Vorgeformt / Preformato	Tela / Cloth / Étoffe / Stoff / Tela	JT64	∅0,15x480	Hilo crudo / Raw thread / Fil brut / Rohes Baumwollfaden / Filo crudo
JT56	∅0,15x485	Hilo crudo / Raw thread / Fil brut / Rohes Baumwollfaden / Filo crudo	JT65	∅0,15x300	Hilo crudo / Raw thread / Fil brut / Rohes Baumwollfaden / Filo crudo
JT57	∅0,15x325	Hilo crudo / Raw thread / Fil brut / Rohes Baumwollfaden / Filo crudo	JT66	∅0,15x600	Hilo crudo / Raw thread / Fil brut / Rohes Baumwollfaden / Filo crudo
JT58	∅0,15x390	Hilo crudo / Raw thread / Fil brut / Rohes Baumwollfaden / Filo crudo	H	∅3	Latón / Brass / Laiton / Messing Ottone

# Essex

Aparejo de velas / Sail rig / Gréement  
Segel takelage / Sartiam da vela

G

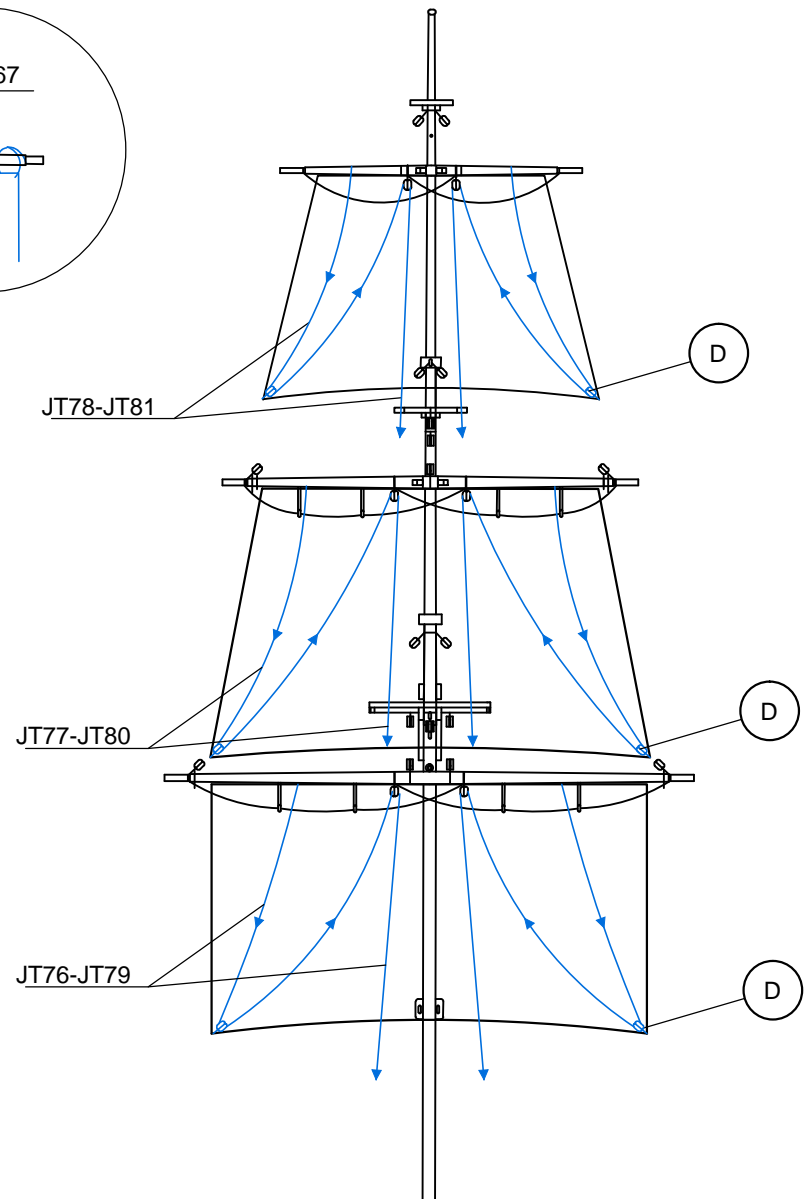
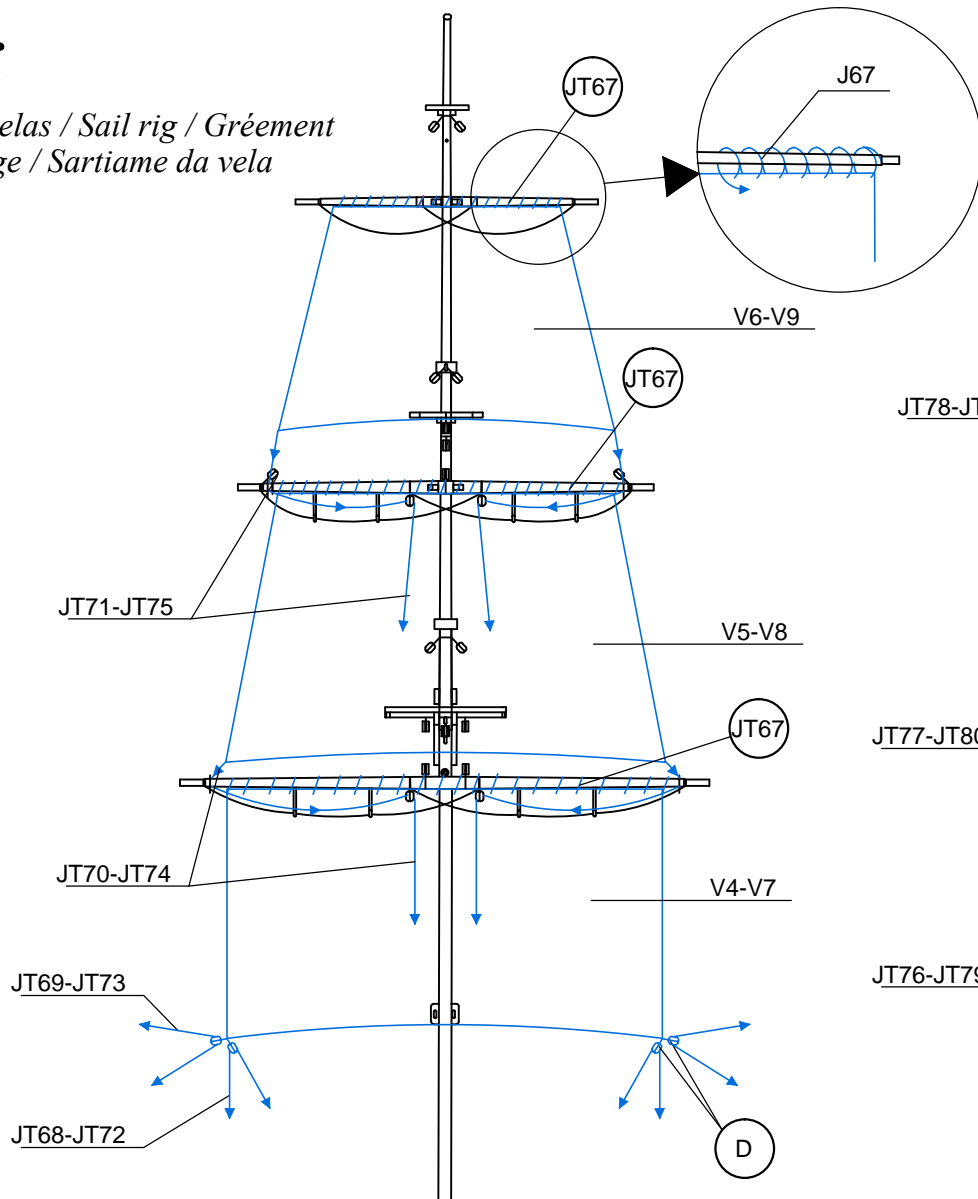

V4	Preformado / Prefomed/ Préformé / Vorgeformt / Preformato	Tela / Cloth / Éttoffe / Stoff / Tela	V8	Preformado / Prefomed/ Préformé / Vorgeformt / Preformato	Tela / Cloth / Éttoffe / Stoff / Tela
JT67	∅0,15x1000	Hilo crudo / Raw thread / Fil brut / Rohes Baumwollfaden / Filo crudo	JT74	∅0,15x445	Hilo crudo / Raw thread / Fil brut / Rohes Baumwollfaden / Filo crudo
JT68	∅0,15x400	Hilo crudo / Raw thread / Fil brut / Rohes Baumwollfaden / Filo crudo	V9	Preformado / Prefomed/ Préformé / Vorgeformt / Preformato	Tela / Cloth / Éttoffe / Stoff / Tela
JT69	∅0,15x325	Hilo crudo / Raw thread / Fil brut / Rohes Baumwollfaden / Filo crudo	JT75	∅0,15x430	Hilo crudo / Raw thread / Fil brut / Rohes Baumwollfaden / Filo crudo
V5	Preformado / Prefomed/ Préformé / Vorgeformt / Preformato	Tela / Cloth / Éttoffe / Stoff / Tela	JT76	∅0,15x425	Hilo crudo / Raw thread / Fil brut / Rohes Baumwollfaden / Filo crudo
JT70	∅0,15x380	Hilo crudo / Raw thread / Fil brut / Rohes Baumwollfaden / Filo crudo	JT77	∅0,15x600	Hilo crudo / Raw thread / Fil brut / Rohes Baumwollfaden / Filo crudo
V6	Preformado / Prefomed/ Préformé / Vorgeformt / Preformato	Tela / Cloth / Éttoffe / Stoff / Tela	JT78	∅0,15x725	Hilo crudo / Raw thread / Fil brut / Rohes Baumwollfaden / Filo crudo
JT71	∅0,15x425	Hilo crudo / Raw thread / Fil brut / Rohes Baumwollfaden / Filo crudo	JT79	∅0,15x520	Hilo crudo / Raw thread / Fil brut / Rohes Baumwollfaden / Filo crudo
V7	Preformado / Prefomed/ Préformé / Vorgeformt / Preformato	Tela / Cloth / Éttoffe / Stoff / Tela	JT80	∅0,15x710	Hilo crudo / Raw thread / Fil brut / Rohes Baumwollfaden / Filo crudo
JT72	∅0,15x475	Hilo crudo / Raw thread / Fil brut / Rohes Baumwollfaden / Filo crudo	JT81	∅0,15x825	Hilo crudo / Raw thread / Fil brut / Rohes Baumwollfaden / Filo crudo
JT73	∅0,15x475	Hilo crudo / Raw thread / Fil brut / Rohes Baumwollfaden / Filo crudo	D	4	Composite / Composite / Composite / Composite / Composite

OcCre  
www.occre.com

H

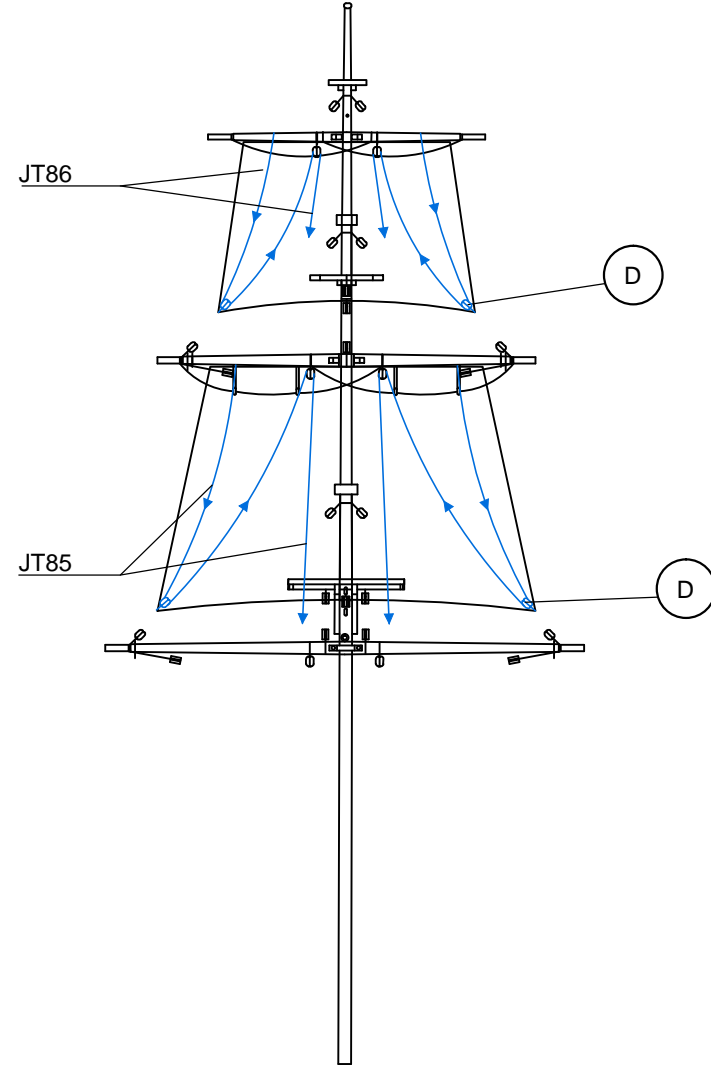
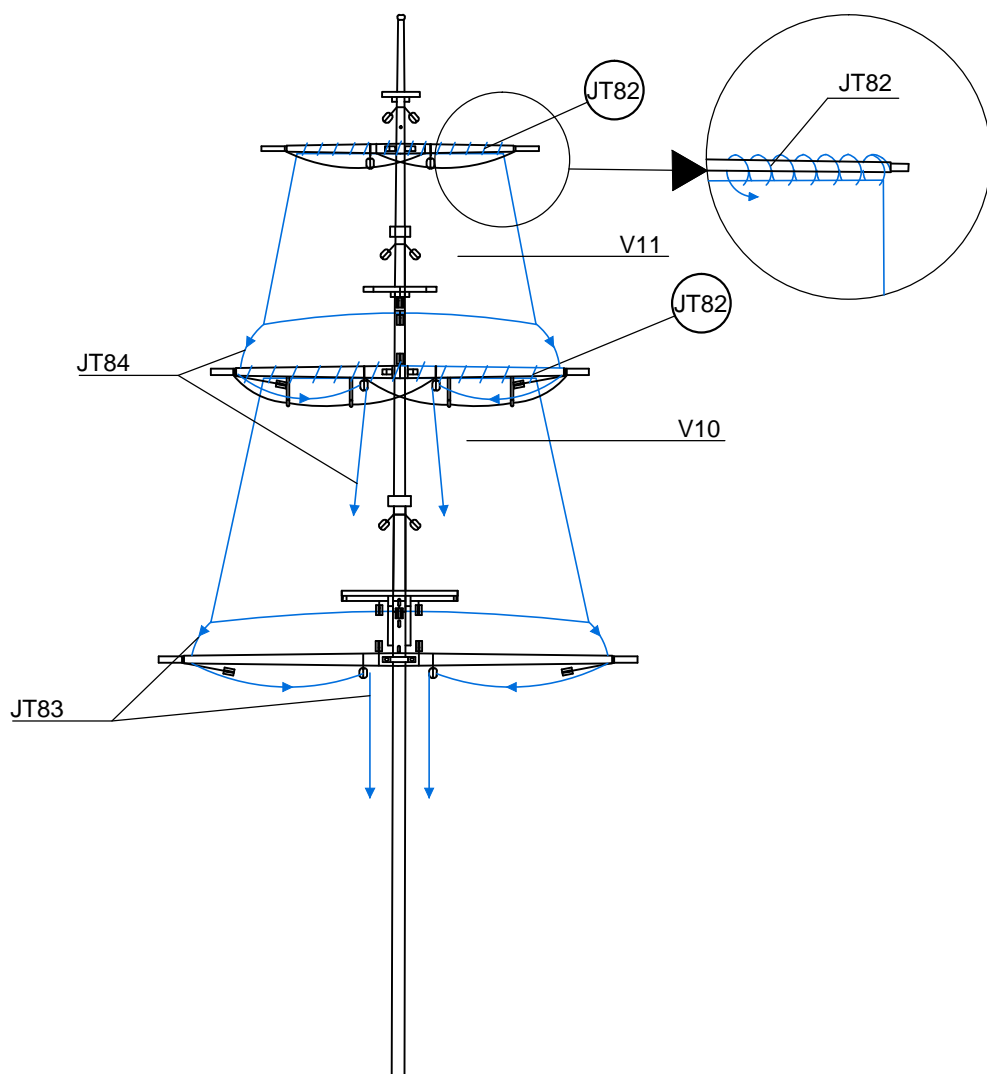

V10	Preformado / Prefomed/ Préformé / Vorgeformt / Preformato	Tela / Cloth / Éttoffe / Stoff / Tela	JT84	∅0,15x500	Hilo crudo / Raw thread / Fil brut / Rohes Baumwollfaden / Filo crudo
JT82	∅0,15x1000	Hilo crudo / Raw thread / Fil brut / Rohes Baumwollfaden / Filo crudo	JT85	∅0,15x600	Hilo crudo / Raw thread / Fil brut / Rohes Baumwollfaden / Filo crudo
JT83	∅0,15x400	Hilo crudo / Raw thread / Fil brut / Rohes Baumwollfaden / Filo crudo	JT86	∅0,15x525	Hilo crudo / Raw thread / Fil brut / Rohes Baumwollfaden / Filo crudo
V11	Preformado / Prefomed/ Préformé / Vorgeformt / Preformato	Tela / Cloth / Éttoffe / Stoff / Tela	D	4	Composite / Composite / Composite / Composite / Composite

# Essex

Aparejo de velas / Sail rig / Gréement  
Segel takelage / Sartiamé da vela

I

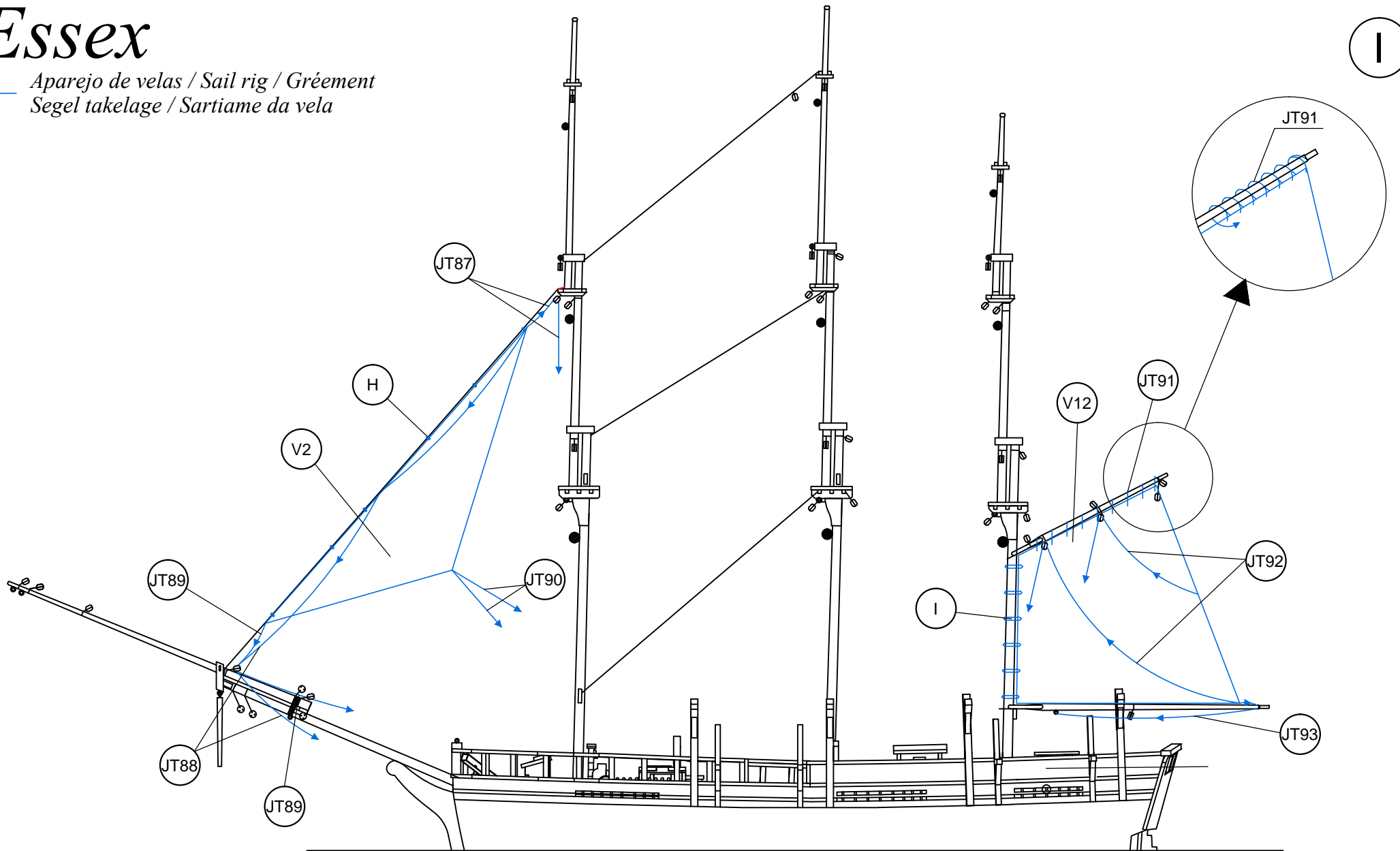

V2	Preformado / Preformed/ Préformé / Vorgeformt / Preformato	Tela / Cloth / Étoffe / Stoff / Tela	JT91	ø0,15x1000	Hilo crudo / Raw thread / Fil brut / Rohes Baumwollfaden / Filo crudo
JT87	ø0,15x425	Hilo crudo / Raw thread / Fil brut / Rohes Baumwollfaden / Filo crudo	JT92	ø0,15x450	Hilo crudo / Raw thread / Fil brut / Rohes Baumwollfaden / Filo crudo
JT88	ø0,15x490	Hilo crudo / Raw thread / Fil brut / Rohes Baumwollfaden / Filo crudo	JT83	ø0,15x325	Hilo crudo / Raw thread / Fil brut / Rohes Baumwollfaden / Filo crudo
JT89	ø0,15x330	Hilo crudo / Raw thread / Fil brut / Rohes Baumwollfaden / Filo crudo	H	ø3	Latón / Brass / Laiton / Messing / Ottone
JT90	ø0,15x285	Hilo crudo / Raw thread / Fil brut / Rohes Baumwollfaden / Filo crudo	I	ø10	Latón / Brass / Laiton / Messing / Ottone
V12	Preformado / Preformed/ Préformé / Vorgeformt	Tela / Cloth / Étoffe / Stoff / Tela			

OcCre  
www.occre.com

J

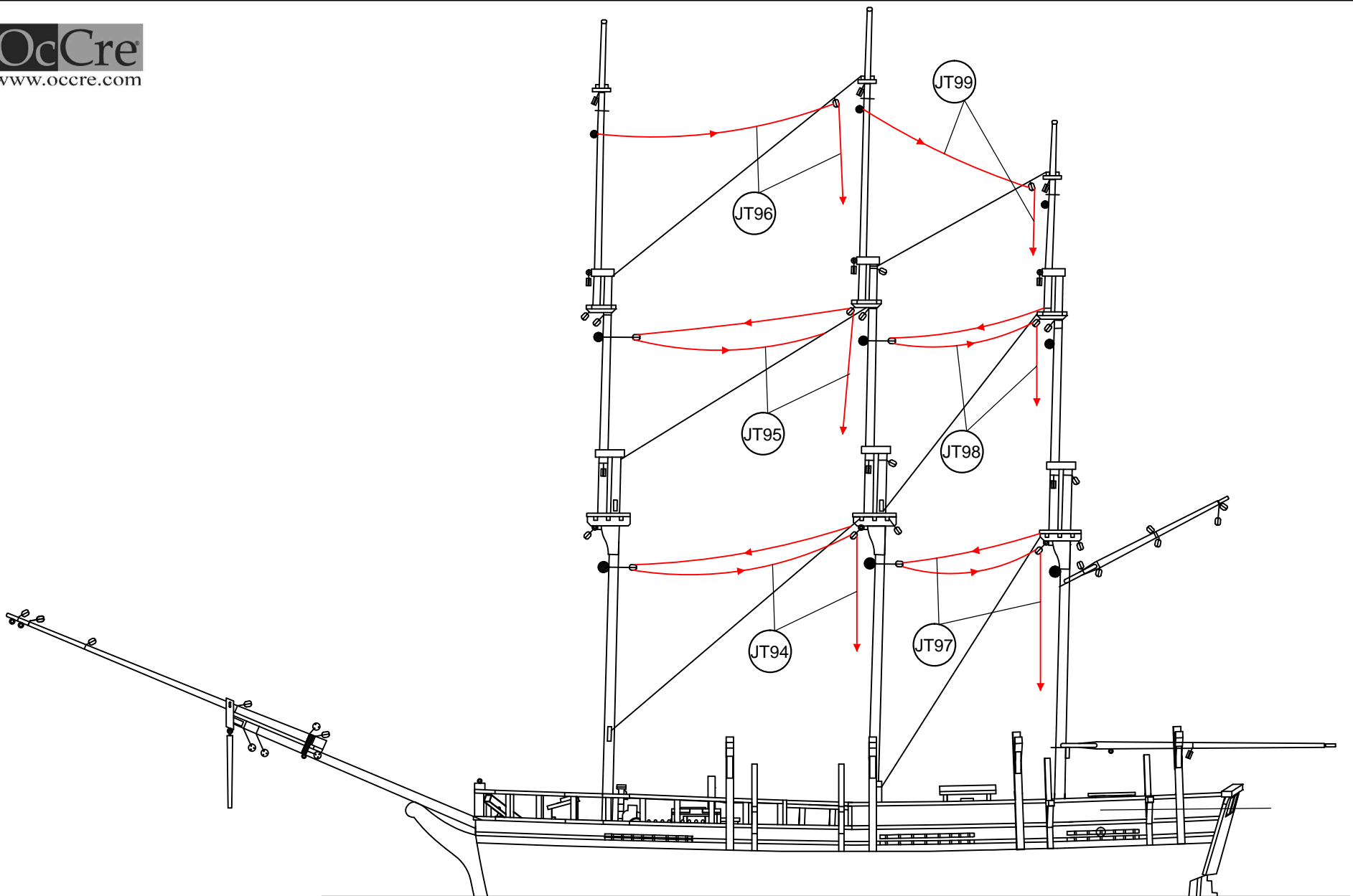

JT94	ø0,15x575	Hilo crudo / Raw thread / Fil brut / Rohes Baumwollfaden / Filo crudo	JT97	ø0,15x550	Hilo crudo / Raw thread / Fil brut / Rohes Baumwollfaden / Filo crudo
JT95	ø0,15x685	Hilo crudo / Raw thread / Fil brut / Rohes Baumwollfaden / Filo crudo	JT98	ø0,15x665	Hilo crudo / Raw thread / Fil brut / Rohes Baumwollfaden / Filo crudo
JT96	ø0,15x700	Hilo crudo / Raw thread / Fil brut / Rohes Baumwollfaden / Filo crudo	JT99	ø0,15x650	Hilo crudo / Raw thread / Fil brut / Rohes Baumwollfaden / Filo crudo



# Essex

Aparejo de velas / Sail rig / Gréement  
Segel takelage / Sartiamé da vela

K

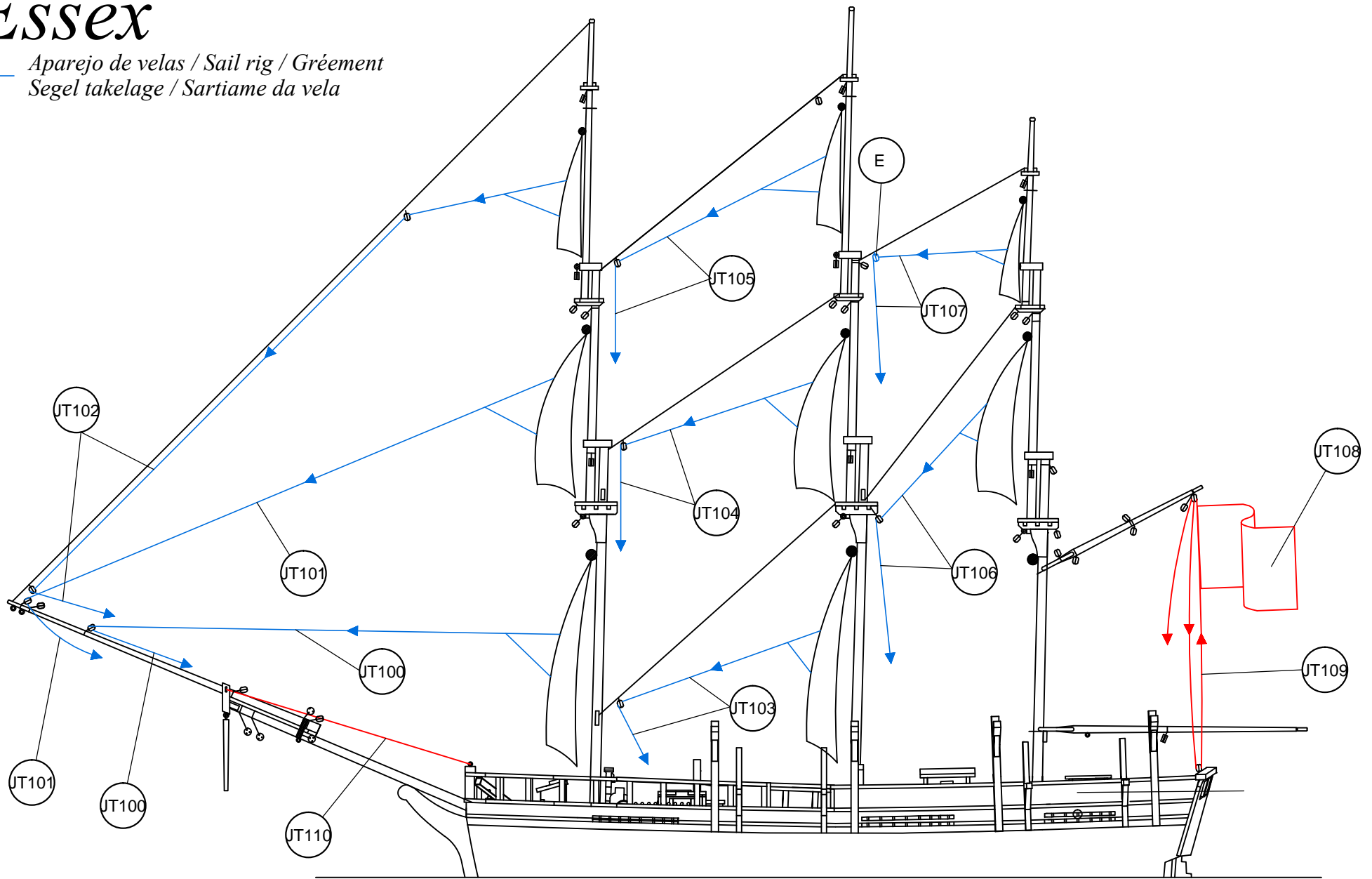

JT100	∅0,15x650	Hilo crudo / Raw thread / Fil brut / Rohes Baumwollfaden / Filo crudo	JT106	∅0,15x580	Hilo crudo / Raw thread / Fil brut / Rohes Baumwollfaden / Filo crudo
JT101	∅0,15x700	Hilo crudo / Raw thread / Fil brut / Rohes Baumwollfaden / Filo crudo	JT107	∅0,15x600	Hilo crudo / Raw thread / Fil brut / Rohes Baumwollfaden / Filo crudo
JT102	∅0,15x790	Hilo crudo / Raw thread / Fil brut / Rohes Baumwollfaden / Filo crudo	JT108	Preformado / Preformed/ Préformé / Vorgeformt / Preformato	Tela / Cloth / Étoffe / Stoff / Tela
JT103	∅0,15x345	Hilo crudo / Raw thread / Fil brut / Rohes Baumwollfaden / Filo crudo	JT109	∅0,15x500	Hilo crudo / Raw thread / Fil brut / Rohes Baumwollfaden / Filo crudo
JT104	∅0,15x565	Hilo crudo / Raw thread / Fil brut / Rohes Baumwollfaden / Filo crudo	JT110	∅0,50x500	Hilo crudo / Raw thread / Fil brut / Rohes Baumwollfaden / Filo crudo
JT105	∅0,15x600	Hilo crudo / Raw thread / Fil brut / Rohes Baumwollfaden / Filo crudo	E	4	Composite / Composite / Composite / Composite / Composite

OcCre  
www.occre.com

L

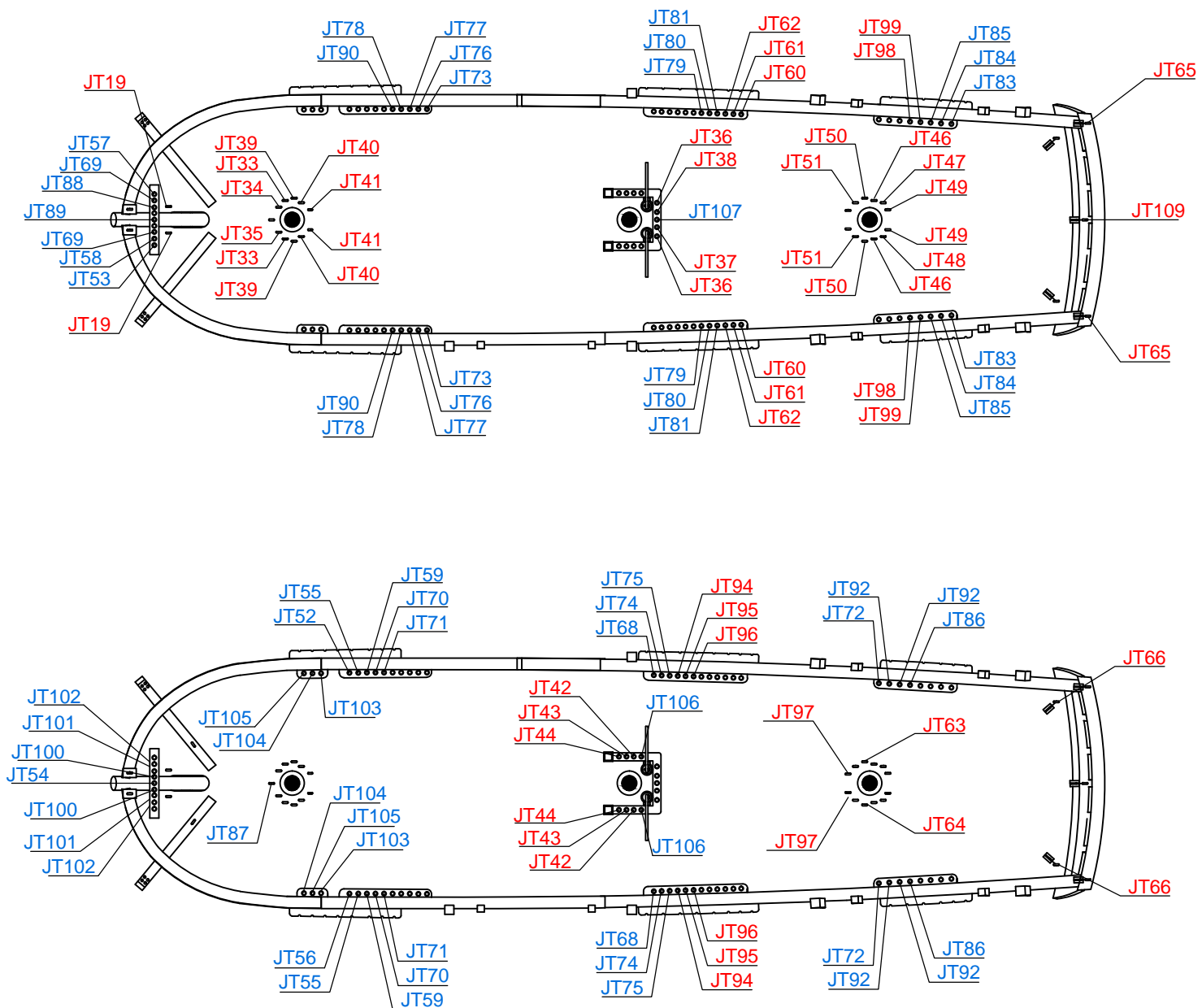

# Essex

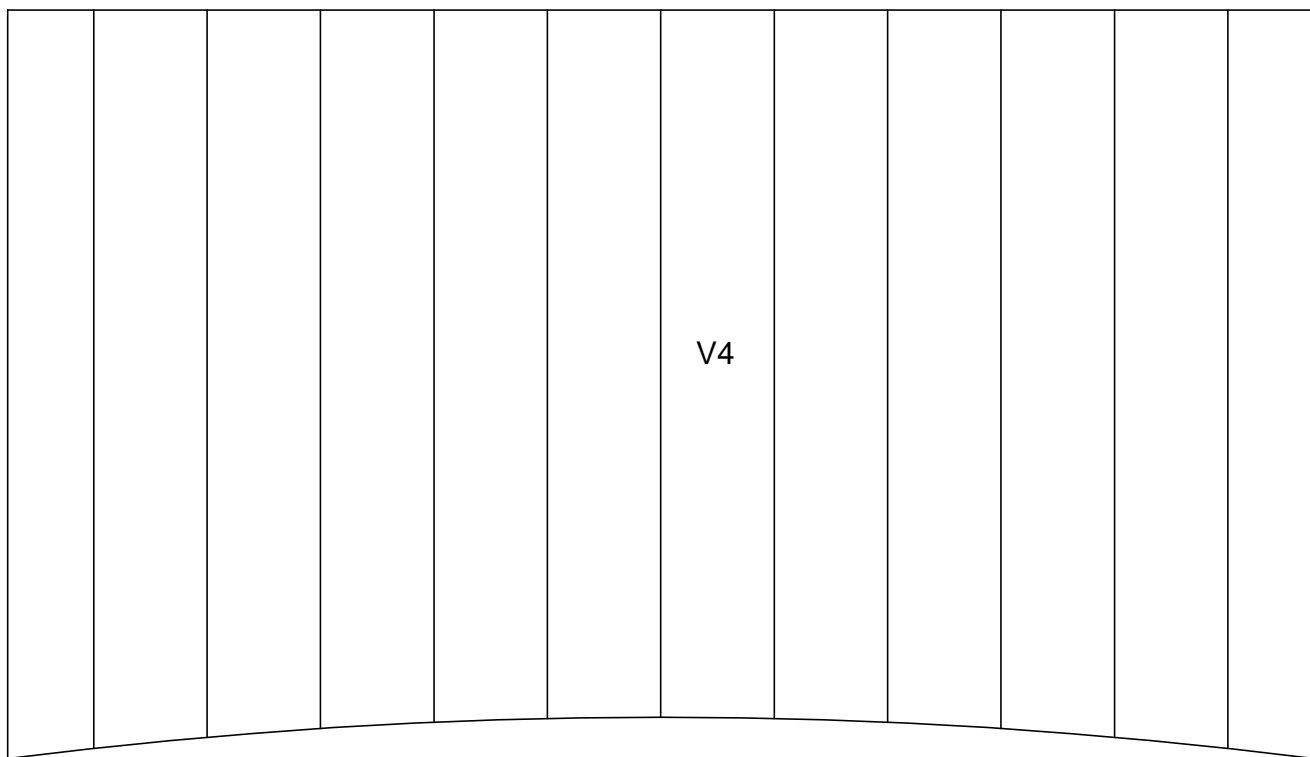
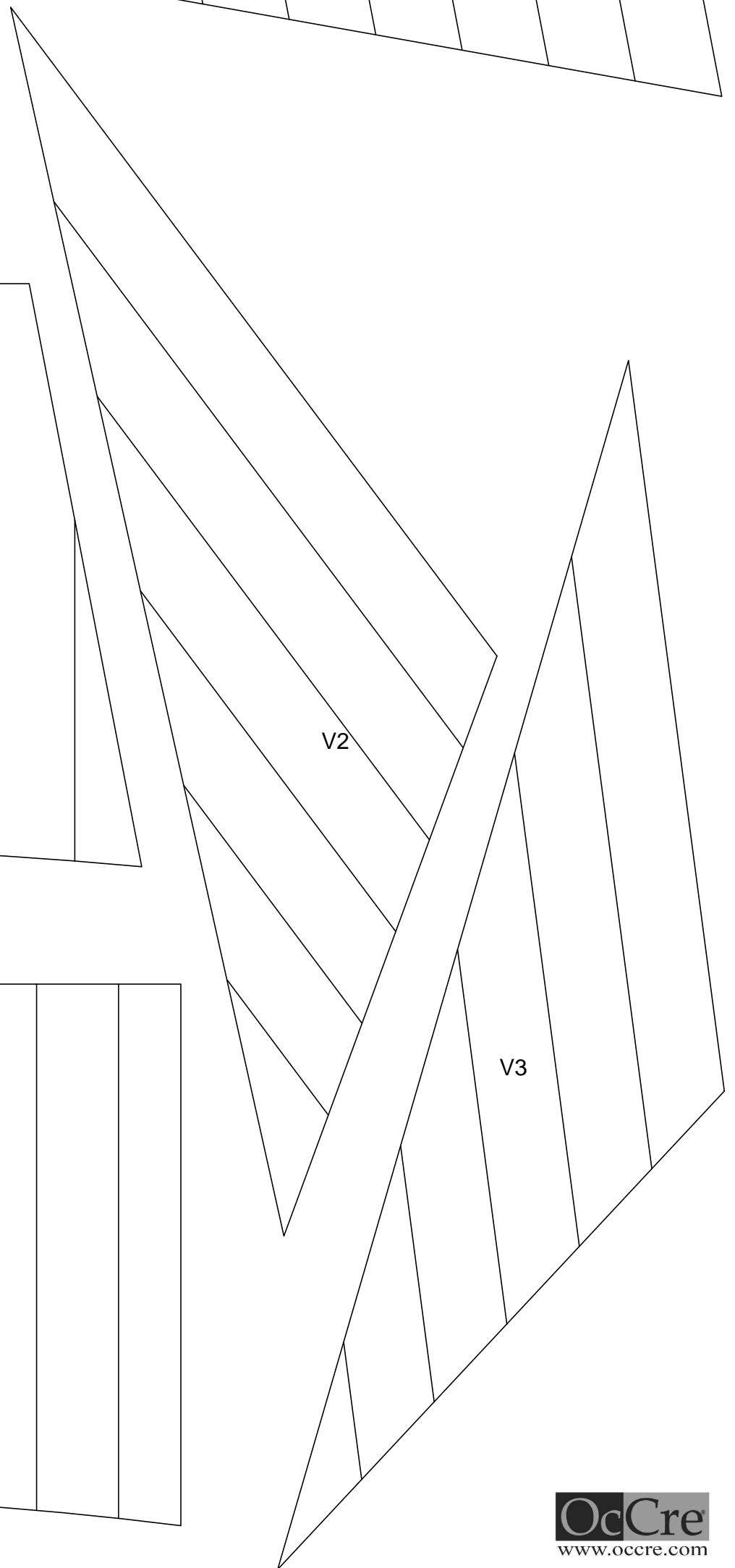
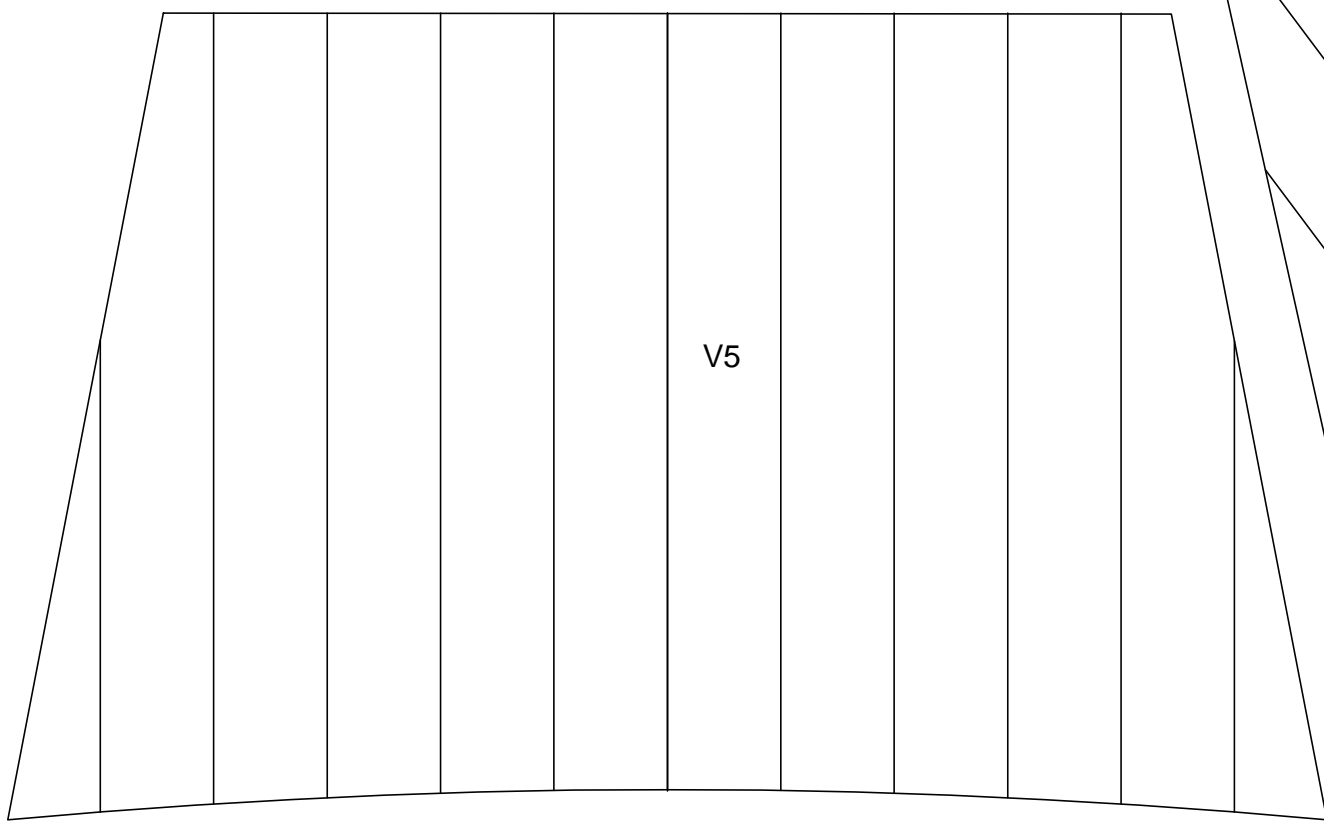
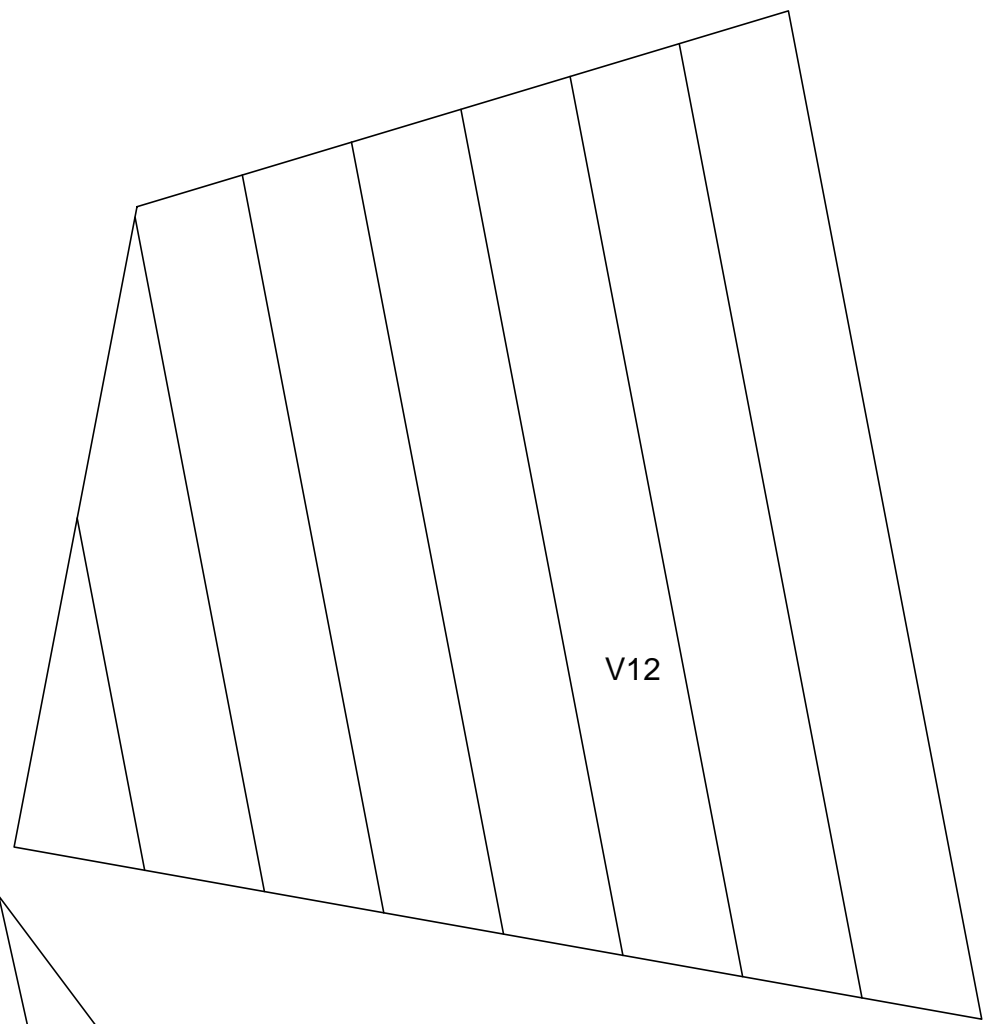
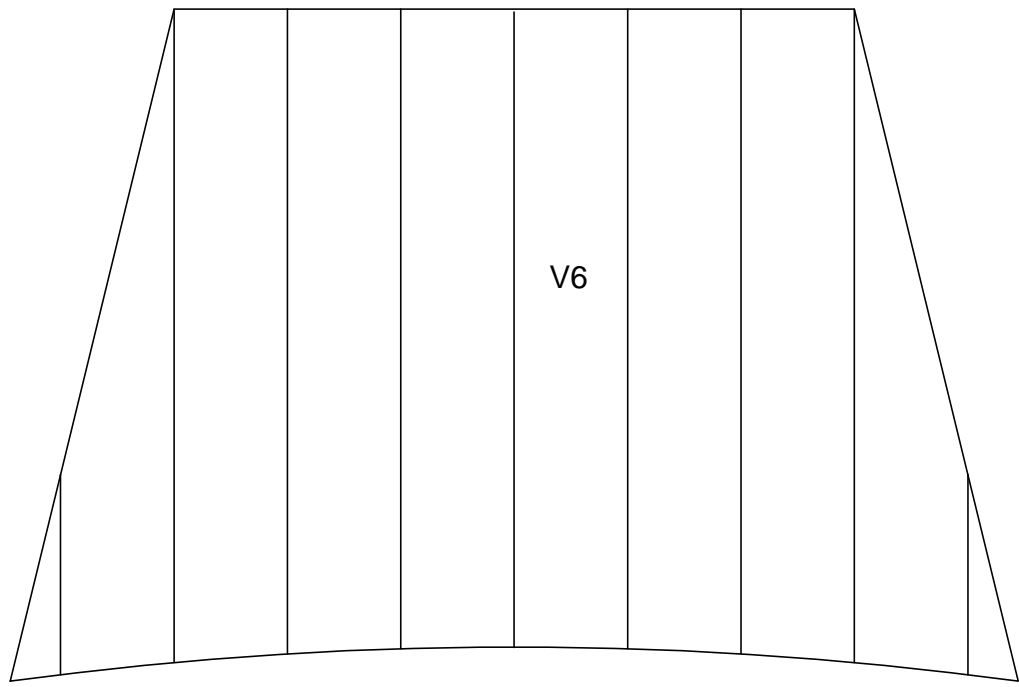

# Essex

