

ANTES DE COMENZAR, RECOPILE TODO EL MATERIAL DE APOYO PARA EL MONTAJE: Instrucciones de montaje / ilustraciones paso a paso / planos y plantillas impresos a escala.

PREPARACIÓN DEL MATERIAL: Para poder identificar correctamente las piezas precortadas, antes de extraerlas de las planchas de madera, marque en ellas la misma numeración que aparece en la hoja "IP" (identificación de piezas), incluida en las instrucciones.

INICIO DEL MONTAJE: Con la ayuda de un cúter y procurando no colocar los dedos en la línea de corte, desprenda las piezas de las planchas eliminando los pequeños nervios que las sujetan. Seguidamente lije con suavidad las piezas con papel de lija de grano fino, para eliminar el repelo de las mismas. El orden numérico del paso a paso indica el orden de elaboración y colocación de las piezas. Es importante comprobar el ajuste de las piezas antes de pegarlas definitivamente.

LISTONES Y VARILLAS: Los modelos incorporan varios tipos de listones y varillas para elaborar las diferentes piezas. La lista de piezas proporciona información sobre el tipo de material y medidas. En algunos casos es conveniente ajustar las medidas sobre el propio modelo, conforme avanzamos en el montaje. De esta manera se consigue un mejor ajuste.

PEGAMENTOS RECOMENDADOS: Cola blanca o de carpintero. Para las uniones de piezas de madera y de todas aquellas piezas que no ofrezcan resistencia.

Pegamento rápido. Para piezas que sean difíciles de sostener y que necesiten un secado casi instantáneo.

Cola de contacto o de zapatero. Para todas aquellas piezas que se forren con chapas finas de madera o metal. En todos los casos, lea siempre las instrucciones de uso del fabricante.

SERVICIO DE ATENCIÓN AL CLIENTE: Para cualquier duda o información sobre el montaje de nuestros productos, puede contactar con nuestro Servicio Técnico en la dirección:

www.occre.com. Le atenderemos con mucho gusto.

BEFORE STARTING, MAKE SURE YOU HAVE ALL THE SUPPORT MATERIAL FOR ASSEMBLING THE MODEL:

Assembly Instructions / Step by step pictures / Plans and templates printed to scale.

PREPARING THE MATERIAL: In order to correctly identify the precut parts, before removing them from the wooden sheets, mark on them the same numbers that appear on the "IP"

(Part Identification) Sheet included with the instructions.

STARTING THE ASSEMBLY: Using a cutter, and making sure you do not put your fingers along the cutting line, remove the parts from the wooden sheets, eliminating the small sprues that hold them in place. In continuation smoothly sand down the parts, using fine grain sandpaper, to eliminate the pickup of the parts. The numerical order indicates the order in which the different parts must be made up and fitted.

STRIPS AND RODS: These models incorporate a variety of different types of strips and rods with which to make up the different parts of the kit. The list of parts proportions information on the type of material and measurements. In some cases it is advisable to adjust the measurements on the basis of the model itself, as assembly progresses. In this way you will achieve a better fit.

RECOMMENDED GLUES: White, or carpenter's glue: For joining pieces of wood together. Mainly used for gluing together the skeleton. Quick-drying glue. For parts that are difficult to hold in their final position and which need to set instantly. Recommended for fitting small parts. Contact or cobbler's glue. For gluing into place the parts that are covered with fine wood veneer to set instantly. In all cases, always follow the manufacturer's recommendations.

CUSTOMER ATTENTION SERVICE: In the case of whatsoever doubt or further information that you may require regarding the assembly of our products, please contact our Technical Service online at the address: www.occre.com. We will be delighted to attend to you.

AVANT DE COMMENCER, VÉRIFIEZ TOUT LE MATÉRIEL DE SOUTIEN POUR LE MONTAGE:

PRÉPARATION DU MATÉRIEL: Pour pouvoir identifier correctement les pièces prédécoupées, avant de les extraire des planches de bois, inscrivez sur elles la même numérotation qui apparaît sur la page « IP » (identification des pièces) comprise dans les instructions.

DÉBUT DU MONTAGE: À l'aide d'un cutter, et en essayant de ne pas poser les doigts sur la ligne de découpe, séparez les pièces des planches en éliminant les petits nerfs qui les retiennent. Puis poncez doucement les pièces à l'aide d'un papier de verre à grain fin, pour éliminer le contrefil. L'ordre numérique des étapes photographiques et des plans indique l'ordre d'élaboration et d'installation des pièces.

LISTEAUX ET BAGUETTES: Les modèles intègrent plusieurs types de listeaux et de baguettes destinés à confectionner les différentes pièces. La liste des pièces indique le type de matériau et les dimensions des pièces. Il est parfois recommandé d'ajuster les mesures sur le modèle lui-même, au fur et à mesure que nous avançons dans le montage. De cette manière, on obtient un meilleur réglage.

COLLES RECOMMANDÉES: Colle blanche ou de menuisier: Pour les unions de pièces en bois et de toutes les pièces qui n'offrent pas de résistance. Colle à séchage rapide: Pour les pièces qui sont difficiles à maintenir dans leur position et qui requièrent un séchage pratiquement instantané. Colle de contact ou de cordonnier: Pour toutes les pièces qui sont recouvertes de fines plaques de bois ou de métal. Dans tous les cas, lisez toujours les instructions d'utilisation du fabricant.

SERVICE CLIENT: Pour toute question ou information concernant le montage de nos produits, vous pouvez contacter notre Service Technique à l'adresse suivante: www.occre.com.

Nous répondrons avec plaisir à vos questions.

PRIMA D'INIZIARE, RIUNIRE TUTTO IL MATERIALE D'APPOGGIO PER IL MONTAGGIO: Istruzioni di montaggio, immagini passo per passo, planimetrie e modelli stampati in scala.

PREPARAZIONE DEL MATERIALE: Per poter identificare in maniera corretta i pezzi che sono stati ritagliati, prima di estrarli dai blister di legno occorre segnarli con la stessa numerazione che è indicata nella pagina "IP" (Identificazione pezzi) che si trova nelle istruzioni.

INIZIO DEL MONTAGGIO: Con l'aiuto di un cutter, ed evitando di collocare le dita lungo la linea di taglio, separare i pezzi dai blister eliminando i piccoli nervi che li mantengono attaccati.

In seguito, scartare con delicatezza i pezzi, utilizzando una carta vetrata a grana fine, onde eliminare le sbavature degli stess. L'ordine numerico del passo per passo indica l'ordine d'elaborazione e di collocazione dei pezzi. È importante verificare che questi combacino bene, prima d'incollarli definitivamente.

ASTE E BACCHETTE: I modelli sono dotati di vari tipi di aste e bacchette per formare i diversi pezzi. L'elenco dei pezzi offre informazioni sul tipo di materiale e sulle misure. In alcuni casi è conveniente modificarne le misure quando sono sul modello, man mano che si avanza nel montaggio. In questo modo si potrà ottenere che combacino meglio.

COLLE RACCOMANDATE: Colla bianca o da falegname: Per unire tra loro i pezzi in legno e tutti quei pezzi che non presentino resistenza. Colla rapida: Per i pezzi difficili da sostenere e per i quali sia necessaria un'asciugatura quasi istantanea. Colla a contatto o da calzolaio: Per tutti quei pezzi che vengono rivestiti con fine lastre di legno o di metallo. In ogni caso, leggere sempre le istruzioni d'uso del produttore.

SERVIZIO ASSISTENZA CLIENTE: Per qualsiasi dubbio o informazione sul montaggio dei nostri prodotti, contattare il nostro Servizio Tecnico al seguente indirizzo: www.occre.com.

Seremo lieti di potervi aiutare.

BEVOR SIE MIT DEM ZUSAMMENBAU BEGINNEN, LEGEN SIE SICH BITTE ALLE HILFSMATERIALIEN FÜR DIE MONTAGE BEREIT:

Bastelanleitung / Maßstabgerechte Skizzen und Schablonen / Skizzen und Vorlagen.

VORBEREITUNG DER MATERIALIEN: Damit die einzelnen Bauteile korrekt zugeordnet werden können, empfehlen wir, auf den Holzplättchen vor dem Herausnehmen mit einem Bleistift die Nummer auf dem Blatt IP (Identifikation Teile) zu markieren.

BEGINN DES ZUSAMMENBAUS: Die Teile mit einem Schneidwerkzeug (Cutter) herauslösen und die kleinen Befestigungsenden entfernen. Dabei darauf achten, die Finger nicht zu verletzen. Danach die Teile vorsichtig mit feinem Schmirgelpapier säubern, um ausgefranste Ränder zu entfernen. Die Nummernfolge der Schritte auf Fotos und Skizzen gibt an, in welcher Reihenfolge die Teile zusammengebaut werden.

LEISTEN UND STÄBE: Die Modelle enthalten mehrere Arten von Leisten und Stäben, aus denen die einzelnen Teile des Bausatzes geformt werden. In einigen Fällen kann es angebracht sein, die Maße im Zuge des Zusammenbaus entsprechend dem Modell anzupassen. Auf diese Weise wird eine bessere Passform erricht.

EMPFOHLENE KLEBSTOFFE: Weißleim (Tischlerleim): Zum Kleben von Strukturteilen und allen nachgiebigen Teilen. Sekundenkleber: Für schwer zu haltende Teile, die schnell verklebt werden müssen. Kontaktkleber (Schusterleim): Für alle Teile, die mit dünnen Holz- oder Metallstücken zum Beplanken oder Verkleiden beklebt werden. Bitte beachten Sie stets die Hinweise des Herstellers.

UNSER KUNDENDIENST: Bei Fragen zum Aufbau unserer Modelle steht Ihnen unser Kundendienst zur Verfügung. Sie erreichen uns online unter: www.occre.com.

Wir stehen Ihnen gern mit Rat und Tipps zur Verfügung.

INSTRUCCIONES DE MONTAJE ENDURANCE

A- Siguiendo el orden alfanumérico inserte y pegue las piezas indicadas en las figuras. Antes de encolar las cuadernas, verifique que encajan correctamente en su posición haciendo “tope” en los encajes correspondientes de la falsa quilla. Es importante que las cuadernas queden completamente perpendiculares a la falsa quilla para que posteriormente encajen bien las cubiertas. Para esta operación utilice como adhesivo cola blanca, (cola de carpintero). Trace una línea longitudinal que divida la cubierta **A18** en dos mitades simétricas. Comience a forrar ajustando la primera tira a la línea de lápiz. Utilice como adhesivo cola de contacto, (cola de zapatero). Con el mango de madera de una herramienta, frote fuertemente las chapas contra la cubierta para que se adhieran con firmeza. Coloque la cubierta bocabajo y corte los sobrantes de las chapas. Después, trace unas líneas para simular la tablazón. Lije la cubierta y aplíquele barniz satinado.

B- Pinte con pintura de color blanco, las zonas de las cuadernas que le indican las fotos. Pegue la cubierta **A18** sobre la estructura del barco. Asegúrese de que encaja correctamente. Para esta operación puede utilizar cola blanca o pegamento rápido. Después, forre las cubiertas **B1, B3 y B5**. Observe los orificios de las cubiertas que debe dejar cubiertos o descubiertos por el forro. Trace las líneas y puntos, y barnice las cubiertas. Inserte y pegue las cubiertas en la estructura del barco.

C- Coloque el casco boca abajo y comience a lijar empezando desde proa y avanzando hacia popa. Debe desbastar las aristas de las cuadernas pero sin deformar su forma original. El lijado del casco ha de quedar simétrico, es decir, que el lateral derecho ha de quedar igual que el izquierdo. Para la zona media del casco, utilice un taco lijador con mayor superficie. El lijado debe ser progresivo y suave. Compruebe con un listón, que el lijado es correcto. Para ello, debe deslizar el listón, sobre las cuadernas, para ver como se ajusta a su forma.

D y E- Introduzca las amuradas **D2** en agua durante unos 20 minutos. Utilice algún objeto cilíndrico para curvar poco a poco las amuradas. Debe presionar la pieza colocando los dedos muy juntos para evitar que se rompa. Después, encole y clave la amurada a la cubierta y a las cuadernas. Para esta operación puede utilizar un clavador y las puntas **A**.

F a H- Elabore y pegue las piezas que le indican las imágenes. Algunas de las piezas deberá pintarlas de color blanco. Continúe el forrado del casco hasta completarlo. Tome los listones **F4, G1 y H1**, y sumérjalos en agua unos veinte minutos. Con esta operación, recuperarán flexibilidad. Después, séquelos con un paño. Comience el forrado del casco ajustando el primer listón a la parte inferior de las amuradas. Observe las imágenes siguientes antes de proceder. Los demás listones del forro debe pegarlos a las cuadernas y entre sí, con cola blanca y fijarlos con puntas. Continúe pegando listones desde proa hasta popa para forrar el casco entero. Deberá cortar a medida y ajustar las piezas para que encajen en los huecos. Si en algún punto le ha quedado alguna traca suelta, puede aplicar pegamento de secado rápido. Si le ha quedado alguna traca más hundida, pegue otra encima y después, líjela. Pegue los refuerzos **H2, H3, H4, H5, H6, H7, H8 y H9**.

I a K- Lime las cabezas de las puntas hasta que queden enrasadas con el forro. Después, lije todo el casco. Debe quedar suave y sin desniveles. Utilizando como adhesivo, cola de contacto, (cola de zapatero), coloque el forro **i1, J1 y J2**. Este segundo forro, se coloca de la misma manera que el primero. Debe cerrar los huecos con cuñas y frotar las chapas con firmeza para que se adhieran al casco. A medida que avance con el forro, abra los orificios que las amuradas llevan de origen. Procure que las tiras de forro queden lo más juntas posible para conseguir un buen acabado. Continúe el forrado del casco hasta completarlo. Después, lije todo el casco con lija de grano fino para dejar su superficie uniforme. Elabore y pegue las piezas que le indican las imágenes. Algunas de las piezas deberá teñirlas con tinte al agua de color nogal. Después aplique una capa de laca tapa-poros incolora a todo el casco y a las piezas añadidas.

L a M- Elabore y pegue las piezas que le indican las imágenes. Utilice la plantilla **PL-01** como guía. Elabore las piezas de decoración del espejo. Si desea pintar el barco, observe previamente las imágenes siguientes y no tiña aquellas piezas que vaya a pintar. Deberá lijar aquellas zonas del casco que barnizó, para que la pintura agarre con firmeza. Utilice cinta de carroceros para aislar las zonas que desee pintar. Para el proceso de pintado utilice pinturas acrílicas al agua; blanco, negro, marrón, etc. Es aconsejable, lijar previamente las piezas que vaya a pintar.

N a Q- Construya las casetas, fórrelas y barnícelas antes de añadirles las piezas de metal. Para elaborar las barandillas, inserte a presión las piezas **N24**. Después, refuerce la unión con pegamento y pase el hilo a través de sus orificios. Añada las piezas a las cubiertas a medida que las fotos se lo indican. Pinte las escaleras y las puertas de color marrón oscuro. Las piezas **P19 y R16**, pínTELas de color negro. Después, destaque sus relieves con pintura de color cobre. Por último, detalle con los diferentes colores que indican las imágenes.

R a T- Inserte las piezas **R15** por los orificios de las piezas **R11 y R12**. Para fijar las piezas **R10 y R15**, deberá anudar su extremo inferior en una pieza **A**. Observe la carta de colores para identificar las referencias de cada color para este modelo.

Para construir las barcas, inserte cada cuaderna en la posición que le indican las imágenes, después lije los conjuntos obtenidos. La primera tira de forro debe colocarla ajustada a las marcas de corte que las cuadernas tienen en su parte inferior. Corte las cuadernas por la marca de corte y sepárelas de la base. Tiña las piezas de color sapelli para diferenciar las piezas. Añada las piezas necesarias para completar las barcas.

Utilizar Betún de Judea para envejecer el barco.

ARBOLADURA

Para elaborar los mástiles, el primer paso a seguir será cortar las varillas según las medidas que indica la lista de piezas, o bien tomarlas directamente de los planos que están impresos a escala 1/1.

Todos los mástiles y vergas tienen cierta conicidad que se deberá realizar.

Para realizar la conicidad a los mástiles, lije las varillas, (con un lijador), aumentando el desgaste de ésta a medida que se acerca al extremo donde se quiere disminuir el diámetro. Haga rodar la varilla para que el desgaste sea igual por todo el contorno hasta conseguir llegar al diámetro que indica el plano.

Para elaborar la conicidad de las vergas, realice las mismas operaciones, pero esta vez a ambos extremos de la varilla.

Deberá teñir o pintar las varillas en función del modelo que esté construyendo.

Para realizar correctamente los mástiles de este modelo se deberá tener en cuenta:

Los planos, las fotos de detalle de los mástiles, las medidas y descripción de materiales de la lista de piezas y las hojas “IP” de identificación de piezas.

Los mástiles se deberán barnizar y algunas de las piezas que los componen se deberán pintar. Véanse las fotos generales de detalle de los mástiles.

Una vez montados y barnizados, deberán colocarles los aparejos, (estrobos, cuadernales, cáncamos, motones, etc.), y fijarlos al barco.

Los mástiles se deben introducir hasta hacer tope en los encajes de la falsa quilla.

JARCIA

Para elaborar la jarcia de este barco, siga el orden alfabético de las figuras impresas de los planos, que indican el orden de colocación: de hilos, vigo-tas, motones, velas, etc, destacados en color rojo. La lista de piezas le orientara sobre el tipo de materiales y medidas a utilizar.

Para simular el envejecido de las velas, se les puede dar un baño con infusión de té, sin hacerlas hervir, y dejarlas secar bien arrugadas. Se colocaran sin planchar para que tengan cuerpo.

ASSEMBLY INSTRUCTIONS ENDURANCE

A: Following the alphanumeric order, fit and glue the parts indicated in the figures. Before gluing the frames into place make sure that they have been correctly and “snugly” fitted into position on the corresponding slots in the false keel. It is important to make sure that the frames are completely perpendicular to the false keel to ensure that the decks fit correctly. Use white (or carpenter’s) glue as the adhesive for this operation. Using a pencil, draw a lengthways line to divide the deck (**A18**) into two symmetrical halves. Start to line the deck with the planking, aligning the first strip along the pencil line. Use contact (or cobbler’s) adhesive. With the wooden handle of a tool energetically press the planking strips against the deck, making sure they are firmly glued in place. Place the deck upside down on your work surface and trim off all of the excess planking strips. Now mark a series of lines and dots to simulate a planking effect and sand the deck down before applying a coat of satin varnish.

B: Paint with white paint, the areas of the frames indicated by the photos. Glue the deck (**A18**), now lined, onto the structure of the ship. It is important to ensure that the deck is resting correctly on the frames. For this operation you can use white glue or fast glue. Next, line decks **B1**, **B3** and **B5**. Note the holes in the decks that should be covered or uncovered by the liner. Trace the lines and dots, and varnish the covers. Insert and glue the decks onto the ship's frame.

C: Place the hull upside down and begin sanding starting from the bow and working towards the stern. You must rough the edges of the frames but without deforming their original shape. The sanding of the hull must be symmetrical, that is, the right side must be the same as the left. For the middle of the hull, use a sanding block with a larger surface. Sanding must be progressive and smooth. Check with a strip that the sanding is correct. To do this, you must slide the slat, over the frames, to see how it adjusts to its shape.

D-E: Soak the **D2** bulwarks in water for about 20 minutes. Use a cylindrical object to bend the bulwarks little by little. You should press the part with your fingers close together to prevent it from breaking. Then glue and nail the bulwark to the deck and to the frames. For this operation you can use a nailer and tips **A**.

F-G-H: Make and glue the pieces indicated by the images. Some of the pieces should be painted white. Continue hull lining until completion. Take the **F4**, **G1** and **H1** strips, and soak them in water for about twenty minutes. With this operation, they will regain flexibility. Then dry them with a cloth. Begin the hull sheathing by adjusting the first strip to the bottom of the bulwarks. Please take a look at the following images before proceeding. The other strips of the lining must be glued to the frames and to each other, with white glue and fixed with nails. Continue gluing slats from bow to stern to line the entire hull. You will need to cut to size and adjust the pieces to fit the gaps. If at any point you have a loose strip, you can apply quick-drying glue. If you have a more strip, stick another on top and then sand it. Glue the **H2**, **H3**, **H4**, **H5**, **H6**, **H7**, **H8** and **H9** reinforcements.

I-J-K: File the nail heads until they are flush with the liner. Then sand the entire hull. It should be smooth and without unevenness.

Using as an adhesive, contact glue, (cobbler's glue), apply the lining **i1**, **J1** and **J2**. This second lining is placed by the same way as the first. You should close the gaps with wedges and rub the strips firmly so that they adhere to the hull. As you proceed with the lining, open the holes that the bulwarks have of origin. Keep the lining strips as close together as possible to achieve a good finish. Continue hull lining until completion. Next, sand the entire hull with fine-grit sandpaper to leave its surface even. Make and glue the pieces indicated by the images. Some of the pieces will need to be stained with walnut water-based stain. Then apply a coat of colorless pore-filler lacquer to the entire hull and to the added parts.

L-M: Make and glue the pieces indicated by the images. Use template **PL-01** as a guide. Make the mirror decoration pieces. If you want to paint the ship, take a look at the following images beforehand and do not stain the parts you are going to paint. You will need to sand those areas of the hull that you varnished, so that the paint holds firmly. Use masking tape to isolate the areas you want to paint. For the painting process use acrylic water-based paints; white, black, brown, etc. It is advisable to previously sand the parts to be painted.

N-O-P-Q: Build the structures, line them, and varnish them before adding the metal pieces. To elaborate the railings, press-in parts **N24**. Then reinforce the joint with glue and pass the thread through its holes. Add pieces to decks as photos indicate.

Paint the stairs and doors dark brown. Parts **P19** and **R16**, paint them black. Then highlight your reliefs with copper-colored paint. Finally, detail with the different colors indicated in the images.

To fix the pieces **R10** and **R15**, you will have to knot their lower end in a piece **A**. Look at the color chart to identify the references of each color for this model.

R-S-T: Insert pieces **R15** through the holes in pieces **R11** and **R12**. To fix the pieces **R10** and **R15**, you must knot their lower end in a piece **A**. Look at the color chart to identify the references of each color for this model. To build the boats, insert each frame in the position indicated by the images, then sand the sets obtained. The first strip of lining must be fitted tightly to the cut marks that the frames have at the bottom. Cut the frames at the cut mark and separate them from the base. Dye the pieces in sapelli color to differentiate the pieces. Add the necessary pieces to complete the boats. Use Judean bitumen to age the ship.

MASTS AND SPARS

In order to make up the masts the first step is to cut the rods to size, as indicated in the parts list, or by taking measurements directly from the plans, which are printed in 1/1 scale.

All of the masts and spars have to have a certain conical shape, which they will have to be given.

In order to achieve this conical shape for the masts, sand down the rod (using a sander), increasing the amount of sanding down as you get closer to the end at which you want to decrease the diameter. Turn the rod so that you sand it down evenly on all sides, until achieving the diameter indicated in the plan.

To achieve this conical shape for the spars carry out the above operations but in this case evenly reducing the diameter at both ends of the rod. The rods will have to be stained or painted, depending on the model that you are building.

To correctly make up the mast for this model you must take into account:

The plans, the close-up photos of the masts and spars, the measurements and material descriptions of the parts list, the “PI” parts identification sheets.

The masts and spars need to be varnished, while some of the parts that make them up are meant to be painted. Examine the general and close-up photos of the masts.

Once the mast and spars has been assembled and varnished fix the tackle (slings, blocks, eyebolts, clump blocks, etc.) into place on the ship. The masts will have to be fully inserted into the sockets prepared to receive them in the false keel.

SAILS AND RIGGING

In order to make up the running gear for this ship follow the alphabetic order of the images printed on the plans, indicating the order for fitting the (ropes, clump blocks, blocks, sails, etc.) highlighted in red. In combination with the parts list this will serve as a guide with regard to the type of material to be used and the measurements.

A method for simulating the aging of the sails is to soak them in an infusion of tea, without boiling, and then leaving them to dry all wrinkled up. Fit them in place without ironing so that they will have a certain consistency.

INSTRUCTIONS DE MONTAGE ENDURANCE

A: Introduire et coller les pièces indiquées sur les figures en suivant l'ordre alphanumérique. Avant de coller les couples, vérifier qu'ils s'emboîtent correctement à leur place et qu'ils pénètrent à fond dans les emboîtures de la fausse quille. Il est important que les couples soient parfaitement perpendiculaires à la fausse quille afin que les ponts s'emboîtent correctement par la suite. Pour réaliser cette opération, on utilisera de la colle blanche (colle de menuisier). Tracer une ligne longitudinale qui divise le pont **A18** en deux moitiés symétriques. Commencer le bordage en plaçant la première latte contre la ligne tracée au crayon. Utiliser de la colle de contact (colle de cordonnier). Frotter énergiquement les plaques contre le pont, à l'aide du manche en bois d'un outil, afin qu'elles y adhèrent fermement. Retourner le pont et couper les excédents des plaques. Tracer ensuite des lignes pour simuler le bordage. Poncer le pont et y appliquer un vernis satiné.

B: Peignez avec de la peinture blanche, les zones des cadres indiquées par les photos. Collez le pont (**A18**), maintenant doublé, sur la structure du navire. Il est important de s'assurer que le plateau repose correctement sur les cadres. Pour cette opération, vous pouvez utiliser de la colle blanche ou de la colle rapide. Ensuite, aligner les ponts **B1**, **B3** et **B5**. Notez les trous dans les ponts qui doivent être couverts ou découverts par la doublure. Tracez les lignes et les points et vernissez les couvertures. Insérez et collez les ponts sur le cadre du navire.

C: Placez la coque à l'envers et commencez à poncer à partir de la proue et en allant vers la poupe. Vous devez ébaucher les bords des cadres mais sans déformer leur forme d'origine. Le ponçage de la coque doit être symétrique, c'est-à-dire que le côté droit doit être le même que le gauche. Pour le milieu de la coque, utilisez un bloc de ponçage avec une plus grande surface. Le ponçage doit être progressif et lisse. Vérifiez avec une bande que le ponçage est correct. Pour ce faire, vous devez faire glisser la latte, sur les cadres, pour voir comment elle s'adapte à sa forme.

D-E: Faites tremper les remparts **D2** dans l'eau pendant environ 20 minutes. Utilisez un objet cylindrique pour plier les remparts petit à petit. Vous devez appuyer sur la pièce avec vos doigts rapprochés pour éviter qu'elle ne se brise. Ensuite, collez et clouez le rempart sur le pont et sur les cadres. Pour cette opération, vous pouvez utiliser une cloueuse et des pointes **A**.

F-G-H: Réalisez et collez les pièces indiquées par les images. Certaines pièces doivent être peintes en blanc. Continuez le revêtement de la coque jusqu'à la fin. Prenez les bandes **F4**, **G1** et **H1** et faites-les tremper dans l'eau pendant une vingtaine de minutes. Avec cette opération, ils retrouveront de la flexibilité. Puis séchez-les avec un chiffon. Commencez le gainage de la coque en ajustant la première bande vers le bas des pavois. Veuillez regarder les images suivantes avant de continuer. Les autres bandes de la doublure doivent être collées aux cadres et les unes aux autres, avec de la colle blanche et fixées avec des clous. Continuez à coller les lattes de la proue à la poupe pour tapisser toute la coque. Vous devrez couper à la taille et ajuster les pièces pour s'adapter aux espaces. Si à un moment donné vous avez une bande lâche, vous pouvez appliquer de la colle à séchage rapide. Si vous avez une bande plus, collez-en une autre sur le dessus, puis poncez-la. Collez les renforts **H2**, **H3**, **H4**, **H5**, **H6**, **H7**, **H8** et **H9**.

I-J-K: Limez les têtes de clous jusqu'à ce qu'elles affleurent avec la doublure. Poncez ensuite toute la coque. Il doit être lisse et sans irrégularité. En utilisant comme adhésif, colle contact, (colle de cordonnier), appliquez la doublure **i1**, **J1** et **J2**. Cette deuxième doublure est placée de la même manière que la première. Vous devez fermer les espaces avec des cales et frotter fermement les bandes pour qu'elles adhèrent à la coque. Au fur et à mesure que vous procédez à la doublure, ouvrez les trous d'origine des pavois. Gardez les bandes de doublure aussi rapprochées que possible pour obtenir une bonne finition. Continuez le revêtement de la coque jusqu'à la fin. Ensuite, poncez toute la coque avec du papier de verre à grain fin pour laisser sa surface uniforme. Réalisez et collez les pièces indiquées par les images. Certaines pièces devront être teintées avec une teinture à base d'eau de noix. Ensuite, appliquez une couche de laque incolore de remplissage des pores sur toute la coque et sur les parties ajoutées.

L-M: Réalisez et collez les pièces indiquées par les images. Utilisez le modèle **PL-01** comme guide. Faites les pièces de décoration de miroir. Si vous souhaitez peindre le navire, jetez un œil aux images suivantes au préalable et ne tachez pas les pièces que vous allez peindre. Vous devrez poncer les zones de la coque que vous avez vernies pour que la peinture tienne fermement. Utilisez du ruban adhésif pour isoler les zones que vous souhaitez peindre. Pour le processus de peinture, utilisez des peintures acryliques à base d'eau; blanc, noir, marron, etc. Il est conseillé de poncer préalablement les pièces à peindre.

N-O-P-Q: Construisez les structures, alignez-les et vernissez-les avant d'ajouter les pièces métalliques. Pour élaborer les garde-corps, enfoncez les pièces **N24**. Renforcez ensuite le joint avec de la colle et passez le fil à travers ses trous. Ajoutez des pièces aux ponts comme l'indiquent les photos. Peignez les escaliers et les portes en brun foncé. Pièces **P19** et **R16**, peignez-les en noir. Mettez ensuite en valeur vos reliefs avec une peinture cuivrée. Enfin, détail avec les différentes couleurs indiquées dans les images.

Pour fixer les pièces **R10** et **R15**, vous devrez nouer leur extrémité inférieure en une pièce **A**. Regardez le nuancier pour identifier les références de chaque couleur pour ce modèle.

R-S-T: Insérez les pièces **R15** dans les trous des pièces **R11** et **R12**. Pour fixer les pièces **R10** et **R15**, vous devez nouer leur extrémité inférieure en une pièce **A**. Regardez le nuancier pour identifier les références de chaque couleur pour ce modèle.

Pour construire les bateaux, insérez chaque cadre dans la position indiquée par les images, puis poncez les décors obtenus. La première bande de doublure doit être bien ajustée aux marques de coupe que les cadres ont en bas. Coupez les cadres à la marque de coupe et séparez-les de la base. Teindre les pièces en couleur sapelli pour différencier les pièces. Ajoutez les pièces nécessaires pour compléter les bateaux.

Utilisez du bitume de Judée pour vieillir le navire.

MÂTURE

La première chose à faire pour confectionner les mâts est de couper les baguettes aux dimensions indiquées dans la liste des pièces ou de prendre ces mesures directement des plans qui sont imprimés à l'échelle 1/1.

Tous les mâts et les vergues possèdent une certaine conicité qui doit être travaillée.

Pour réaliser la conicité des mâts, poncer les baguettes (avec une ponceuse) en augmentant le dégrossissage au fur et à mesure qu'on s'approche de l'extrémité où l'on souhaite diminuer le diamètre. Faire rouler la baguette afin que l'usure soit égale sur tout le contour jusqu'à ce qu'on obtienne le diamètre indiqué sur le plan.

Effectuer les mêmes opérations pour réaliser la conicité des vergues mais, dans ce cas, aux deux extrémités de la baguette.

Il faudra teinter ou peindre les baguettes en fonction de la maquette qui sera construite.

Pour réaliser correctement les mâts de cette maquette, il faudra tenir compte :

Des plans, des photos de détail des mâts, des dimensions et de la description des matériaux de la liste des pièces, des feuilles « IP » d'identification des pièces.

Les mâts devront être vernis et certaines des pièces qui les composent devront être peintes. Voir les photos générales de détail des mâts.

Lorsque les mâts seront montés et vernis, on placera leurs appareils (estropes, moufles, pitons, poulies, etc.) et on les attachera au bateau. Les mâts doivent être introduits de sorte qu'ils s'emboîtent à fond contre la fausse quille.

GRÉEMENT

Pour réaliser le gréement de ce bateau, on suivra l'ordre alphabétique des figures imprimées des plans, qui indiquent l'ordre de montage (fils, caps de mouton, poulies, etc.) mis en évidence en rouge. La liste des pièces indique le type de matériaux et les dimensions à utiliser.

Pour simuler le vieillissement des voiles, on peut les faire tremper dans une infusion de thé, sans les faire bouillir, et les laisser sécher bien chiffonnées. Les voiles seront placées non repassées afin d'avoir du volume.

ISTRUZIONI DI MONTAGGIO ENDURANCE

- A-** Seguendo l'ordine alfanumerico, inserire e incollare i pezzi indicati nelle figure. Prima di incollare le coste, verificare che si inseriscano correttamente e fino in fondo nelle corrispondenti sedi della falsa chiglia. È importante che le coste siano perfettamente perpendicolari alla falsa chiglia in modo che i ponti si adattino bene in seguito. Per realizzare questa operazione, utilizzare colla bianca (colla da falegname) come adesivo. Tracciare una linea longitudinale che divida il ponte **A18** in due metà simmetriche. Iniziare a rivestire collocando la prima striscia sulla linea tracciata a matita. Utilizzare una colla a contatto (colla per scarpe) come adesivo. Utilizzando il manico di legno di un utensile, strofinare le lastre contro il ponte in modo tale che aderiscano saldamente. Capovolgere il ponte per ritagliare le parti di lastre che avanzano. Quindi, tracciare delle righe per simulare il fasciame. Scartavetrare il ponte e applicare la vernice satinata incolore.
- B-** Dipingi con vernice bianca, le aree delle cornici indicate dalle foto. Incollare il ponte (**A18**), ora rivestito, sulla struttura della nave. È importante assicurarsi che il piatto poggi correttamente sui telai. Per questa operazione è possibile utilizzare colla bianca o colla rapida. Quindi, i ponti di linea **B1**, **B3** e **B5**. Notare i fori nei ponti che dovrebbero essere coperti o scoperti dal rivestimento. Traccia le linee e i punti e vernicia le copertine. Inserisci e incolla i ponti sul telaio della nave.
- C-** Posizionare lo scafo capovolto e iniziare a carteggiare partendo da prua e procedendo verso poppa. Bisogna sgrossare i bordi delle cornici ma senza deformarne la forma originale. La levigatura dello scafo deve essere simmetrica, cioè il lato destro deve essere lo stesso del sinistro. Per la parte centrale dello scafo, utilizzare un blocco di levigatura con una superficie più ampia. La carteggiatura deve essere progressiva e liscia. Verificare con una striscia che la levigatura sia corretta. Per fare ciò, devi far scorrere la lamella, sopra i telai, per vedere come si adatta alla sua forma.
- D-E-** Immergere le murate **D2** in acqua per circa 20 minuti. Usa un oggetto cilindrico per piegare le murate poco a poco. Dovresti premere la parte con le dita vicine per evitare che si rompa. Quindi incollare e inchiodare il baluardo al ponte e ai telai. Per questa operazione è possibile utilizzare una chiodatrice e punte **A**.
- F-G-H-** Realizza e incolla i pezzi indicati dalle immagini. Alcuni pezzi dovrebbero essere dipinti di bianco. Continuare a rivestire lo scafo fino al completamento. Prendi le strisce **F4**, **G1** e **H1** e immergile in acqua per circa venti minuti. Con questa operazione riacquisteranno flessibilità. Quindi asciugatele con un panno. Iniziare il rivestimento dello scafo regolando la prima striscia sul fondo delle murate. Si prega di dare un'occhiata alle seguenti immagini prima di procedere. Le altre strisce di rivestimento devono essere incollate ai telai e tra loro, con colla bianca e fissate con chiodi. Continua ad incollare le lamelle da prua a poppa per rivestire l'intero scafo. Dovrai tagliare a misura e regolare i pezzi per adattarli agli spazi vuoti. Se in qualsiasi momento hai una striscia allentata, puoi applicare la colla ad asciugatura rapida. Se hai una striscia in più, attaccane un'altra sopra e poi carteggia. Incolla i rinforzi **H2**, **H3**, **H4**, **H5**, **H6**, **H7**, **H8** e **H9**.
- I-J-K-** Lima le teste dei chiodi finché non sono a filo con il rivestimento. Quindi carteggiare l'intero scafo. Dovrebbe essere liscio e senza irregolarità. Usando come adesivo, colla a contatto, (colla da calzolaio), applicare il rivestimento **i1**, **J1** e **J2**. Questo secondo rivestimento è posizionato allo stesso modo del primo. Dovresti chiudere le fessure con dei cunei e strofinare bene le strisce in modo che aderiscano allo scafo. Man mano che si procede con il rivestimento, aprire i fori che hanno le murate di origine. Tenere le strisce di rivestimento il più vicine possibile per ottenere una buona finitura. Continuare a rivestire lo scafo fino al completamento. Successivamente, carteggiare l'intero scafo con carta vetrata a grana fine per lasciare la sua superficie uniforme. Realizza e incolla i pezzi indicati dalle immagini. Alcuni pezzi dovranno essere macchiati con una macchia a base d'acqua di noce. Quindi applicare una mano di vernice riempitiva per pori incolore su tutto lo scafo e sulle parti aggiunte.
- L-M-** Realizza e incolla i pezzi indicati dalle immagini. Usa il modello **PL-01** come guida. Realizza i pezzi di decorazione dello specchio. Se vuoi dipingere la nave, dai un'occhiata alle seguenti immagini in anticipo e non macchiare le parti che stai per dipingere. Dovrai carteggiare quelle aree dello scafo che hai verniciato, in modo che la vernice rimanga saldamente. Usa del nastro adesivo per isolare le aree che vuoi dipingere. Per il processo di verniciatura utilizzare vernici acriliche a base d'acqua; bianco, nero, marrone, ecc. Si consiglia di carteggiare preventivamente le parti da verniciare.
- N-O-P-Q-** Costruisci le strutture, foderale e verniciabile prima di aggiungere i pezzi di metallo. Per elaborare le ringhiere, premere gli elementi **N24**. Quindi rinforzare il giunto con la colla e passare il filo attraverso i suoi fori. Aggiungi pezzi ai mazzi come indicano le foto. Dipingi le scale e le porte di un marrone scuro. Parti **P19** e **R16**, dipingile di nero. Quindi evidenzia i tuoi rilievi con vernice color rame. Infine dettaglio con i diversi colori indicati nelle immagini. Per fissare i pezzi **R10** e **R15**, dovrai annodare la loro estremità inferiore in un pezzo **A**. Guarda la cartella colori per identificare i riferimenti di ogni colore per questo modello.
- R-S-T-** Inserire i pezzi **R15** attraverso i fori nei pezzi **R11** e **R12**. Per fissare i pezzi **R10** e **R15**, devi annodare la loro estremità inferiore in un pezzo **A**. Guarda la cartella colori per identificare i riferimenti di ogni colore per questo modello.
- Per costruire le barche, inserire ogni cornice nella posizione indicata dalle immagini, quindi carteggiare i set ottenuti. La prima striscia di rivestimento deve essere fissata saldamente ai segni di taglio che i telai hanno nella parte inferiore. Taglia le cornici in corrispondenza del segno di taglio e separale dalla base. Tingi i pezzi di colore sapelli per differenziarli. Aggiungi i pezzi necessari per completare le barche. Usa bitume della Giudea per invecchiare la nave.

ALBERATURA

- Per realizzare l'alberatura, il primo passo da seguire sarà quello di tagliare le aste secondo le misure indicate nell'elenco dei pezzi, oppure prenderle direttamente dalle planimetrie che sono stampate in scala 1/1. Tutti gli alberi e i pennoni hanno una certa conicità che si dovrà ottenere. Per ottenere la conicità degli alberi, occorre scartavetrare le aste (con una smerigliatrice), aumentando l'azione della stessa a misura che ci si avvicina all'estremità dove si deve diminuire il diametro. Far girare l'asta affinché la smerigliatura sia uguale su tutto il contorno, fino ad arrivare al diametro indicato nella planimetria. Per ottenere la conicità dei pennoni, realizzare le stesse operazioni, ma in questo caso su entrambe le estremità dell'asta. Si dovranno verniciare o tingere le aste in funzione del modello che si stia realizzando. Per realizzare gli alberi di questo modello in maniera corretta si dovranno utilizzare: Le planimetrie; le foto dettagliate degli alberi; le misure e la descrizione dei materiali nell'elenco dei pezzi; le pagine "IP" con l'identificazione dei pezzi. Gli alberi devono essere smaltati ed alcuni dei pezzi che li compongono devono essere verniciati. Vedi le foto generali dettagliate degli alberi. Una volta montati e smaltati, devono essere collocati gli attrezzi (stroppi, quarnali, golfare, bozzelli, ecc.) e fissati al vascello. Gli alberi devono essere introdotti fino in fondo negli appositi incastri della falsa chiglia.

SARTIA

- Per elaborare la sartia di questo vascello occorre seguire l'ordine alfabetico delle figure stampate delle planimetrie, che indicano l'ordine di collocazione delle cime, delle bigotte, dei bozzelli, delle vele, ecc., risaltati in colore rosso. L'elenco dei pezzi serve ad orientare in merito al tipo di materiali ed alle misure da utilizzare. Per simulare l'invecchiamento delle vele, queste possono essere bagnate con te, senza farle bollire, e poi lasciarle asciugare mantenendole ben arrugate. Poi si collocano senza stirarle, affinché mantengano corpo.

BASTELANLEITUNG ENDURANCE

A- Die auf den Abbildungen gezeigten Teile in der angegebenen Reihenfolge einsetzen und aufkleben. Vor dem Aufkleben der Spanten sicherstellen, dass die sie korrekt sitzen und mit den dazugehörigen Einkerbungen des falschen Kiels abschließen. Die Spanten müssen vollkommen senkrecht auf dem falschen Kiel stehen, damit danach die Decks gut eingesetzt werden können. Für diese Operation muss weißer Kleber (Tischlerleim) verwendet werden. Eine Längslinie ziehen, mit der das Deck **A18** in zwei symmetrische Hälften geteilt wird. Dabei die erste Plankenreihe an der Bleistiftlinie ausrichten. Zum Kleben Kontaktkleber verwenden (Schusterleim). Mit dem Holzstiel eines Werkzeugs das Furnier kräftig auf das Deck reiben, bis es fest haftet. Das Deck mit der Oberseite nach unten aufsetzen und die überstehenden Teile der Leisten abschneiden. Abschließend Linien ziehen und Markierungen anbringen, um die Schiffsbeplankung zu simulieren. Das Deck glatt schmirgeln und mit satinlack.

B- Malen Sie mit weißer Farbe die Bereiche der Rahmen, die auf den Fotos angegeben sind. Kleben Sie die Abdeckung **A18** auf den Schiffsrahmen. Stellen Sie sicher, dass es richtig passt. Für diesen Vorgang können Sie Weißkleber oder Schnellkleber verwenden. Dann deckt die Linie **B1**, **B3** und **B5** ab. Beachten Sie die Löcher in den Abdeckungen, die vom Liner abgedeckt oder unbedeckt bleiben sollten. Verfolgen Sie die Linien und Punkte und lackieren Sie die Abdeckungen. Setzen Sie die Abdeckungen ein und kleben Sie sie auf den Schiffsrahmen.

C- Drehen Sie den Rumpf um und beginnen Sie mit dem Schleifen, beginnend am Bug und in Richtung Heck. Sie müssen die Kanten der Rahmen rauhen, ohne jedoch ihre ursprüngliche Form zu verformen. Das Schleifen des Helms muss symmetrisch sein, dh die rechte Seite muss mit der linken identisch sein. Verwenden Sie für die Mitte des Helms einen Schleifblock mit einer größeren Oberfläche. Das Schleifen muss progressiv und glatt sein. Überprüfen Sie mit einem Streifen, ob der Schleifvorgang korrekt ist. Dazu müssen Sie die Lamelle über die Rahmen schieben, um zu sehen, wie sie sich an ihre Form anpasst.

D-E- Die **D2**-Bollwerke ca. 20 Minuten in Wasser einweichen. Verwenden Sie einen zylindrischen Gegenstand, um die Bollwerke nach und nach zu biegen. Sie sollten das Teil mit den Fingern eng aneinander drücken, damit es nicht bricht. Kleben und nageln Sie dann das Bollwerk auf das Deck und auf die Rahmen. Für diesen Vorgang können Sie einen Nagler und Tipps **A** verwenden.

F-G-H- Machen und kleben Sie die in den Bildern angegebenen Teile. Einige der Stücke sollten weiß gestrichen sein. Setzen Sie die Rumpfauskleidung bis zur Fertigstellung fort. Nehmen Sie die Lamellen **F4**, **G1** und **H1** und legen Sie sie etwa zwanzig Minuten lang in Wasser. Mit dieser Operation gewinnen sie wieder Flexibilität. Dann trockne sie mit einem Tuch. Beginnen Sie mit der Rumpfummantelung, indem Sie den ersten Streifen an der Unterseite der Bollwerke einstellen. Bitte schauen Sie sich die folgenden Bilder an, bevor Sie fortfahren. Die anderen Streifen des Futters müssen mit weißem Kleber auf die Rahmen und aneinander geklebt und mit Punkten fixiert werden. Kleben Sie die Lamellen weiter vom Bug bis zum Heck, um den gesamten Rumpf auszukleiden. Sie müssen zuschneiden und die Teile an die Lücken anpassen. Wenn Sie zu irgendeinem Zeitpunkt einen losen Strake haben, können Sie schnell trocknenden Kleber auftragen. Wenn Sie einen versunkenen Strake haben, kleben Sie einen anderen darauf und schleifen Sie ihn dann. Kleben Sie die Verstärkungen **H2**, **H3**, **H4**, **H5**, **H6**, **H7**, **H8** und **H9**.

I-J-K- Feilen Sie die Nagelköpfe, bis sie bündig mit dem Liner sind. Dann den gesamten Rumpf schleifen. Es sollte glatt und ohne Unebenheiten sein. Tragen Sie als Klebstoff Kontaktkleber (Schusterkleber) auf und tragen Sie die Auskleidung **i1**, **J1** und **J2** auf. Dieses zweite Futter wird auf die gleiche Weise wie das erste platziert. Sie sollten die Lücken mit Keilen schließen und die Streifen fest reiben, damit sie am Rumpf haften. Öffnen Sie beim Fortfahren die Löcher, aus denen die Bollwerke stammen. Halten Sie die Futterstreifen so nah wie möglich beieinander, um ein gutes Finish zu erzielen. Setzen Sie die Rumpfauskleidung bis zur Fertigstellung fort. Anschließend den gesamten Rumpf mit feinkörnigem Schleifpapier schleifen, um eine gleichmäßige Oberfläche zu erhalten. Machen und kleben Sie die Teile, die auf den Bildern angegeben sind. Einige der Stücke müssen mit Walnuss-Wasserflecken gefärbt werden. Tragen Sie dann eine Schicht farblosen Porenfülllacks auf den gesamten Rumpf und die hinzugefügten Teile auf.

L-M- Machen und kleben Sie die Teile, die auf den Bildern angegeben sind. Verwenden Sie die Vorlage **PL-01** als Richtlinie. Machen Sie die Spiegeldekoration Stücke. Wenn Sie das Schiff streichen möchten, schauen Sie sich vorher die folgenden Bilder an und färben Sie die Teile, die Sie streichen möchten, nicht. Sie müssen die Bereiche des Rumpfes, die Sie lackiert haben, schleifen, damit die Farbe festhält. Verwenden Sie Klebeband, um die Bereiche zu isolieren, die Sie malen möchten. Verwenden Sie für den Malprozess Acrylfarben auf Wasserbasis. weiß, schwarz, braun usw. Es ist ratsam, die zu lackierenden Teile vorher zu schleifen.

N-O-P-Q- Bauen Sie die Strukturen auf, zeichnen Sie sie aus und lackieren Sie sie, bevor Sie die Metallteile hinzufügen. Drücken Sie zum Ausarbeiten der Geländer die Teile **N24** ein. Verstärken Sie dann die Verbindung mit Klebstoff und führen Sie den Faden durch die Löcher. Fügen Sie den Decks Teile hinzu, wie auf den Fotos angegeben. Malen Sie die Treppen und Türen dunkelbraun. Teile **P19** und **R16** schwarz lackieren. Heben Sie dann Ihre Reliefs mit kupferfarbener Farbe hervor. Zum Schluss Details mit den verschiedenen in den Bildern angegebenen Farben. Um die Teile **R10** und **R15** zu befestigen, müssen Sie ihr unteres Ende in einem Teil **A** verknoten. Sehen Sie sich die Farbkarte an, um die Referenzen jeder Farbe für dieses Modell zu identifizieren.

R-S-T- Führen Sie die Teile **R15** durch die Löcher in den Teilen **R11** und **R12**. Um die Teile **R10** und **R15** zu befestigen, müssen Sie ihr unteres Ende in einem Teil **A** verknoten. Sehen Sie sich die Farbkarte an, um die Referenzen jeder Farbe für dieses Modell zu identifizieren.

Um die Boote zu bauen, setzen Sie jeden Rahmen an der in den Bildern angegebenen Position ein und schleifen Sie die erhaltenen Sätze. Der erste Futterstreifen muss fest an den Schnittmarkierungen angebracht sein, die die Rahmen unten haben. Schneiden Sie die Rahmen an der Schnittmarke ab und trennen Sie sie von der Basis. Färben Sie die Stücke in Sapelli-Farbe, um die Stücke zu unterscheiden. Fügen Sie die notwendigen Teile hinzu, um die Boote zu vervollständigen.

Verwenden Sie jüdisches Bitumen, um das Schiff zu altern.

BEMASTUNG

Zur Herstellung der Masten müssen zuerst die Stäbe entsprechend der Maße zurecht geschnitten werden, die in der Teileliste angegeben sind oder die direkt anhand der Skizze abgemessen wurde. Die Skizzen sind im Maßstab 1/1 angefertigt.

Alle Masten und Rahen müssen leicht konisch verlaufen und vor dem Einbau entsprechen vorbereitet werden.

Um die Masten in Konusform zu bringen, müssen die Masten (mit einer Feile) zurecht geschliffen werden, und zwar in der Form, dass sie nach oben hin verjüngt werden. Die Stäbe dabei drehen und an allen Seiten gleichmäßig abschleifen, bis sie zu dem auf der Skizze angegebenen Durchmesser passen.

Um die Rahen in Konusform zu bringen, ebenso verfahren, allerdings hier an beiden Enden der Stangen.

Die Stäbe in Abhängigkeit von dem Modell färben oder anmalen.

Um die Masten dieses Schiffsbaumodells richtig vorzubereiten, müssen die folgenden Punkte beachtet werden:

Die Skizzen, detailfotos der Masten, maße und Materialien der Teileliste, IP-Blätter zur Identifikation der Bauteile.

Die Masten müssen lackiert werden und einige der Einzelteile der Masten müssen angemalt werden. Siehe Fotos mit allgemeiner Ansicht der Masten

Nach Aufstellung und Lackierung der Masten wird die Takelung (Stroppe, Rollenblöcke, Ösen, Blockrollen etc.) an den Masten und dann am Schiff befestigt. Die Masten müssen eingesetzt werden, bis sie an die Einkerbungen des falschen Kiels stoßen.

TAKELAGE

Zur Takelung des Schiffsmodells die alphabetische Reihenfolge der Abbildungen befolgen, auf denen die Anbringung der Takelung (Faden, Klampböcke, Blockrollen usw.) erläutert wird. Sie sind in Rot hervorgehoben. Auf der Teileliste sehen Sie, welche Materialien zum Bau des Modells notwendig sind.

Zur künstlichen Alterung der Segel die Stoffstücke in Tee legen (nicht kochen) und trocknen lassen, bis die Stoffe faltig werden. Die Segel ohne vorheriges Bügeln anbringen, damit sie Volumen haben.









<i>Listado de piezas / Parts List / Liste des pièces / Teilleiste / Elenco delle parti</i>			
Nº/No. / Nº / Nr. No	Cantidad / Quantity / Quantité / Menge / Quantità	Medidas / Measurements / Dimensions / Maße / Misure	Material / Material / Matériau / Material / Materiale
A1	1	Precortado / Precut / Prédécoupé / Vorgeschnitten / Pretagliatto / Pretagliatto	Tablero / Plywood / Planche / Sperrholz / Tavola
A2 - A12	11	Precortado / Precut / Prédécoupé / Vorgeschnitten / Pretagliatto / Pretagliatto	Tablero / Plywood / Planche / Sperrholz / Tavola
A13	3	Precortado / Precut / Prédécoupé / Vorgeschnitten / Pretagliatto / Pretagliatto	Tablero / Plywood / Planche / Sperrholz / Tavola
A14-A15	4	Precortado / Precut / Prédécoupé / Vorgeschnitten / Pretagliatto / Pretagliatto	Tablero / Plywood / Planche / Sperrholz / Tavola
A16-A17	4	Precortado / Precut / Prédécoupé / Vorgeschnitten / Pretagliatto / Pretagliatto	Tablero / Plywood / Planche / Sperrholz / Tavola
A18	1	Precortado / Precut / Prédécoupé / Vorgeschnitten / Pretagliatto / Pretagliatto	Tablero / Plywood / Planche / Sperrholz / Tavola
A19	22	0,6x5x290	Sicomoro / Sycamore / Sycomore / Bergahorn / Sicomoro
B1	1	Precortado / Precut / Prédécoupé / Vorgeschnitten / Pretagliatto	Tablero / Plywood / Planche / Sperrholz / Tavola
B2	18	0,6x5x110	Sicomoro / Sycamore / Sycomore / Bergahorn / Sicomoro
B3	1	Precortado / Precut / Prédécoupé / Vorgeschnitten / Pretagliatto	Tablero / Plywood / Planche / Sperrholz / Tavola
B4	22	0,6x5x230	Sicomoro / Sycamore / Sycomore / Bergahorn / Sicomoro
B5	1	Precortado / Precut / Prédécoupé / Vorgeschnitten / Pretagliatto	Tablero / Plywood / Planche / Sperrholz / Tavola
B6	18	0,6x5x100	Sicomoro / Sycamore / Sycomore / Bergahorn / Sicomoro
B7	2	Precortado / Precut / Prédécoupé / Vorgeschnitten / Pretagliatto	Tablero / Plywood / Planche / Sperrholz / Tavola
B8	2	Precortado / Precut / Prédécoupé / Vorgeschnitten / Pretagliatto	Tablero / Plywood / Planche / Sperrholz / Tavola
B9	2	Precortado / Precut / Prédécoupé / Vorgeschnitten / Pretagliatto	Tablero / Plywood / Planche / Sperrholz / Tavola
C1	1	2x5x600	Tilo / Lime wood / Tilleul / Linde / Tiglio
C2	1	1x3x92	Tilo / Lime wood / Tilleul / Linde / Tiglio
C3	1	1x3x100	Tilo / Lime wood / Tilleul / Linde / Tiglio
C4	1	1x3x46	Tilo / Lime wood / Tilleul / Linde / Tiglio
C5	1	1x3x30	Tilo / Lime wood / Tilleul / Linde / Tiglio
D1	2	Precortado / Precut / Prédécoupé / Vorgeschnitten / Pretagliatto / Pretagliatto	Tablero / Plywood / Planche / Sperrholz / Tavola
D2	2	Precortado / Precut / Prédécoupé / Vorgeschnitten / Pretagliatto / Pretagliatto	Tablero / Plywood / Planche / Sperrholz / Tavola
E1	2	Precortado / Precut / Prédécoupé / Vorgeschnitten / Pretagliatto / Pretagliatto	Tablero / Plywood / Planche / Sperrholz / Tavola
E2	2	2x5x120	Tilo / Lime wood / Tilleul / Linde / Tiglio
E3	1	2x5x10	Tilo / Lime wood / Tilleul / Linde / Tiglio
E4	2	1x3x14	Tilo / Lime wood / Tilleul / Linde / Tiglio
E5	1	1x3x75	Tilo / Lime wood / Tilleul / Linde / Tiglio
F1	1	1x3x103	Tilo / Lime wood / Tilleul / Linde / Tiglio
F2	2	1x3x240	Tilo / Lime wood / Tilleul / Linde / Tiglio
F3	18	1x3x24	Tilo / Lime wood / Tilleul / Linde / Tiglio
F4	6	2x5x236	Tilo / Lime wood / Tilleul / Linde / Tiglio
G1	8	2x5x600	Tilo / Lime wood / Tilleul / Linde / Tiglio
H1	46	2x5x600	Tilo / Lime wood / Tilleul / Linde / Tiglio
H2-H9	16	Precortado / Precut / Prédécoupé / Vorgeschnitten / Pretagliatto	Tablero / Plywood / Planche / Sperrholz / Tavola
i1	10	0,6x5x600	Sapelly / Sapelli / Sapelli / Sapelly-Holz / Sapelli
J1	46	0,6x5x600	Sapelly / Sapelli / Sapelli / Sapelly-Holz / Sapelli
J2	6	0,6x5x230	Sicomoro / Sycamore / Sycomore / Bergahorn / Sicomoro
K1	2	2x5x15	Tilo / Lime wood / Tilleul / Linde / Tiglio
K2	2	Precortado / Precut / Prédécoupé / Vorgeschnitten / Pretagliatto / Pretagliatto	Tablero / Plywood / Planche / Sperrholz / Tavola
K3	2	2x5x237	Tilo / Lime wood / Tilleul / Linde / Tiglio
K4	2	2x5x10	Tilo / Lime wood / Tilleul / Linde / Tiglio
K5	2	2x5x220	Tilo / Lime wood / Tilleul / Linde / Tiglio
K6	2	2x2x120	Tilo / Lime wood / Tilleul / Linde / Tiglio
K7	2	2x2x220	Tilo / Lime wood / Tilleul / Linde / Tiglio
K8	1	Precortado / Precut / Prédécoupé / Vorgeschnitten / Pretagliatto / Pretagliatto	Tablero / Plywood / Planche / Sperrholz / Tavola
K9-K11	3	Precortado / Precut / Prédécoupé / Vorgeschnitten / Pretagliatto / Pretagliatto	Tablero / Plywood / Planche / Sperrholz / Tavola
K12	1	Precortado / Precut / Prédécoupé / Vorgeschnitten / Pretagliatto / Pretagliatto	Tablero / Plywood / Planche / Sperrholz / Tavola
L1	1	2x2x125	Tilo / Lime wood / Tilleul / Linde / Tiglio
L2	2	2x2x600	Tilo / Lime wood / Tilleul / Linde / Tiglio
L3	1	2x2x135	Tilo / Lime wood / Tilleul / Linde / Tiglio
L4	19	Preformado / Preformed/ Préformé / Vorgeformt / Preformato	Latón / Brass / Latón / Messing / Ottone
L5	2	Preformado / Preformed/ Préformé / Vorgeformt / Preformato	Latón / Brass / Latón / Messing / Ottone
L6	1	Preformado / Preformed/ Préformé / Vorgeformt / Preformato	Latón / Brass / Latón / Messing / Ottone
L7	1	Preformado / Preformed/ Préformé / Vorgeformt / Preformato	Latón / Brass / Latón / Messing / Ottone

<i>Listado de piezas / Parts List / Liste des pièces / Teilleiste / Elenco delle parti</i>			
Nº/No. / N° / Nr. No	Cantidad / Quantity / Quantité / Menge / Quantità	Medidas / Measurements / Dimensions / Maße / Misure	Material / Material / Matériau / Material / Materiale
L8	2	Preformado / Preformed/ Préformé / Vorgeformt / Preformato	Latón / Brass / Latón / Messing / Ottone
L9	1	Precortado / Precut / Prédécoupé / Vorgeschnitten / Pretagliatto / Pretagliatto	Tablero / Plywood / Planche / Sperrholz / Tavola
L10	1	Preformado / Preformed/ Préformé / Vorgeformt / Preformato	Metal / Metal / Metal / Metall / Metallo
M1	2	Preformado / Preformed/ Préformé / Vorgeformt / Preformato	Latón / Brass / Latón / Messing / Ottone
M2	2	∅1x3	Latón / Brass / Latón / Messing / Ottone
M3	4	Preformado / Preformed/ Préformé / Vorgeformt / Preformato	Latón / Brass / Latón / Messing / Ottone
M4	3	Preformado / Preformed/ Préformé / Vorgeformt / Preformato	Madera / Wood / Bois / Holz / Legno
M5	8	Preformado / Preformed/ Préformé / Vorgeformt / Preformato	Metal / Metal / Metal / Metall / Metallo
M6	4	2x5x20	Tilo / Lime wood / Tilleul / Linde / Tiglio
M7	1	Preformado / Preformed/ Préformé / Vorgeformt / Preformato	Madera / Wood / Bois / Holz / Legno
M8	2	Preformado / Preformed/ Préformé / Vorgeformt / Preformato	Metal / Metal / Metal / Metall / Metallo
M9	1	2x5x40	Tilo / Lime wood / Tilleul / Linde / Tiglio
M10	2	1x4x235	Tilo / Lime wood / Tilleul / Linde / Tiglio
M11	2	4x4x50	Tilo / Lime wood / Tilleul / Linde / Tiglio
N1	2	Precortado / Precut / Prédécoupé / Vorgeschnitten / Pretagliatto / Pretagliatto	Tablero / Plywood / Planche / Sperrholz / Tavola
N2	4	Precortado / Precut / Prédécoupé / Vorgeschnitten / Pretagliatto / Pretagliatto	Tablero / Plywood / Planche / Sperrholz / Tavola
N3	4	Precortado / Precut / Prédécoupé / Vorgeschnitten / Pretagliatto / Pretagliatto	Tablero / Plywood / Planche / Sperrholz / Tavola
N4	4	1x3x18	Tilo / Lime wood / Tilleul / Linde / Tiglio
N5	4	1x3x20	Tilo / Lime wood / Tilleul / Linde / Tiglio
N6	2	Precortado / Precut / Prédécoupé / Vorgeschnitten / Pretagliatto / Pretagliatto	Tablero / Plywood / Planche / Sperrholz / Tavola
N7	14	1x3x22	Tilo / Lime wood / Tilleul / Linde / Tiglio
N8	4	1x3x22	Tilo / Lime wood / Tilleul / Linde / Tiglio
N9	4	1x3x24	Tilo / Lime wood / Tilleul / Linde / Tiglio
N10	1	Precortado / Precut / Prédécoupé / Vorgeschnitten / Pretagliatto / Pretagliatto	Tablero / Plywood / Planche / Sperrholz / Tavola
N11	1	Precortado / Precut / Prédécoupé / Vorgeschnitten / Pretagliatto / Pretagliatto	Tablero / Plywood / Planche / Sperrholz / Tavola
N12	1	Precortado / Precut / Prédécoupé / Vorgeschnitten / Pretagliatto / Pretagliatto	Tablero / Plywood / Planche / Sperrholz / Tavola
N13	2	Precortado / Precut / Prédécoupé / Vorgeschnitten / Pretagliatto / Pretagliatto	Tablero / Plywood / Planche / Sperrholz / Tavola
N14	19	0,6x5x180	Sicomoro / Sycamore / Sycomore / Bergahorn / Sicomoro
N15	4	1x3x58	Tilo / Lime wood / Tilleul / Linde / Tiglio
N16	2	1x3x64	Tilo / Lime wood / Tilleul / Linde / Tiglio
N17	2	1x3x33	Tilo / Lime wood / Tilleul / Linde / Tiglio
N18	2	1x3x19	Tilo / Lime wood / Tilleul / Linde / Tiglio
N19	4	1x3x21	Tilo / Lime wood / Tilleul / Linde / Tiglio
N20	1	1x3x54	Tilo / Lime wood / Tilleul / Linde / Tiglio
N21	1	1x3x17	Tilo / Lime wood / Tilleul / Linde / Tiglio
N22	10	Preformado / Preformed/ Préformé / Vorgeformt / Preformato	Latón / Brass / Latón / Messing / Ottone
N23	4	Preformado / Preformed/ Préformé / Vorgeformt / Preformato	Latón / Brass / Latón / Messing / Ottone
N24	15	Preformado / Preformed/ Préformé / Vorgeformt / Preformato	Latón / Brass / Latón / Messing / Ottone
N25	1	∅0,15x300	Hilo crudo / Raw thread / Fil brut / Rohes Baumwollfaden / Filo crudo
N26	1	∅0,15x100	Hilo crudo / Raw thread / Fil brut / Rohes Baumwollfaden / Filo crudo
o1	2	∅4x75	Tilo / Lime wood / Tilleul / Linde / Tiglio
o2	2	Preformado / Preformed/ Préformé / Vorgeformt / Preformato	Metal / Metal / Metal / Metall / Metallo
o3	2	∅1x15	Latón / Brass / Latón / Messing / Ottone
o4	2	6x6x15	Tilo / Lime wood / Tilleul / Linde / Tiglio
o5	4	1x3x17	Tilo / Lime wood / Tilleul / Linde / Tiglio
o6	2	Precortado / Precut / Prédécoupé / Vorgeschnitten / Pretagliatto / Pretagliatto	Tablero / Plywood / Planche / Sperrholz / Tavola
o7	2	Precortado / Precut / Prédécoupé / Vorgeschnitten / Pretagliatto / Pretagliatto	Tablero / Plywood / Planche / Sperrholz / Tavola
o8	2	Precortado / Precut / Prédécoupé / Vorgeschnitten / Pretagliatto / Pretagliatto	Tablero / Plywood / Planche / Sperrholz / Tavola
o9	1	Precortado / Precut / Prédécoupé / Vorgeschnitten / Pretagliatto / Pretagliatto	Tablero / Plywood / Planche / Sperrholz / Tavola
o10	2	13x45	Acetato / Acetate / Acétate / Acetat / Acetato
o11	2	1x3x47	Tilo / Lime wood / Tilleul / Linde / Tiglio
o12	2	1x3x26	Tilo / Lime wood / Tilleul / Linde / Tiglio
o13	1	∅1,5x47	Latón / Brass / Latón / Messing / Ottone
o14	1	∅12x74	Tilo / Lime wood / Tilleul / Linde / Tiglio
o15	1	Precortado / Precut / Prédécoupé / Vorgeschnitten / Pretagliatto / Pretagliatto	Tablero / Plywood / Planche / Sperrholz / Tavola

<i>Listado de piezas / Parts List / Liste des pièces / Teilleiste / Elenco delle parti</i>			
Nº/No./ N° / Nr. No	Cantidad / Quantity / Quantité / Menge / Quantità	Medidas / Measurements / Dimensions / Maße / Misure	Material / Material / Matériau / Material / Materiale
o16	3	ø1x42	Latón / Brass / Latón / Messing / Ottone
o17	1	Precortado / Precut / Prédécoupé / Vorgeschnitten / Pretagliatto / Pretagliatto	Tablero / Plywood / Planche / Sperrholz / Tavola
o18	1	ø1,5x39	Latón / Brass / Latón / Messing / Ottone
o19	2	Preformado / Preformed/ Préformé / Vorgeformt / Preformato	Metal / Metal / Metal / Metall / Metallo
P1-P3	4	Precortado / Precut / Prédécoupé / Vorgeschnitten / Pretagliatto / Pretagliatto	Tablero / Plywood / Planche / Sperrholz / Tavola
P4	9	0,6x5x30	Sapelly / Sapelli / Sapelli / Sapelly-Holz / Sapelli
P5	1	1x3x15	Tilo / Lime wood / Tilleul / Linde / Tiglio
P6	2	1x3x24	Tilo / Lime wood / Tilleul / Linde / Tiglio
P7	1	Precortado / Precut / Prédécoupé / Vorgeschnitten / Pretagliatto / Pretagliatto	Tablero / Plywood / Planche / Sperrholz / Tavola
P8	2	2x2x20	Tilo / Lime wood / Tilleul / Linde / Tiglio
P9	2	1x5x22	Tilo / Lime wood / Tilleul / Linde / Tiglio
P10	2	ø1x3	Latón / Brass / Latón / Messing / Ottone
P11-P14	5	Precortado / Precut / Prédécoupé / Vorgeschnitten / Pretagliatto / Pretagliatto	Tablero / Plywood / Planche / Sperrholz / Tavola
P15	12	0,6x5x25	Sapelly / Sapelli / Sapelli / Sapelly-Holz / Sapelli
P16	2	1x3x20	Tilo / Lime wood / Tilleul / Linde / Tiglio
P17	2	1x3x18	Tilo / Lime wood / Tilleul / Linde / Tiglio
P18	6	1x3x24	Tilo / Lime wood / Tilleul / Linde / Tiglio
P19	1	Preformado / Preformed/ Préformé / Vorgeformt / Preformato	Metal / Metal / Metal / Metall / Metallo
P20	1	ø1,5x10	Latón / Brass / Latón / Messing / Ottone
P21	1	Precortado / Precut / Prédécoupé / Vorgeschnitten / Pretagliatto / Pretagliatto	Tablero / Plywood / Planche / Sperrholz / Tavola
P22	6	1x3x17	Tilo / Lime wood / Tilleul / Linde / Tiglio
P23	2	1x5x17	Tilo / Lime wood / Tilleul / Linde / Tiglio
P24	2	1x5x19	Tilo / Lime wood / Tilleul / Linde / Tiglio
Q1-Q4	4	Precortado / Precut / Prédécoupé / Vorgeschnitten / Pretagliatto / Pretagliatto	Tablero / Plywood / Planche / Sperrholz / Tavola
Q5	2	0,6x5x15	Sapelly / Sapelli / Sapelli / Sapelly-Holz / Sapelli
Q6	6	0,6x5x20	Sapelly / Sapelli / Sapelli / Sapelly-Holz / Sapelli
Q7	4	0,6x5x15	Sapelly / Sapelli / Sapelli / Sapelly-Holz / Sapelli
Q8	2	1x3x17	Tilo / Lime wood / Tilleul / Linde / Tiglio
Q9	1	1x3x14	Tilo / Lime wood / Tilleul / Linde / Tiglio
Q10	2	8x13	Acetato / Acetate / Acétate / Acetat / Acetato
Q11	6	ø0,50x9	Latón / Brass / Latón / Messing / Ottone
Q12	1	Precortado / Precut / Prédécoupé / Vorgeschnitten / Pretagliatto / Pretagliatto	Tablero / Plywood / Planche / Sperrholz / Tavola
Q13	2	2x2x17	Tilo / Lime wood / Tilleul / Linde / Tiglio
Q14	2	1x5x16	Tilo / Lime wood / Tilleul / Linde / Tiglio
Q15	2	ø1x3	Latón / Brass / Latón / Messing / Ottone
Q16	68	Preformado / Preformed/ Préformé / Vorgeformt / Preformato	Latón / Brass / Latón / Messing / Ottone
Q17	4	ø0,15x300	Hilo crudo / Raw thread / Fil brut / Rohes Baumwollfaden / Filo crudo
Q18	2	ø0,15x250	Hilo crudo / Raw thread / Fil brut / Rohes Baumwollfaden / Filo crudo
Q19	4	ø0,15x200	Hilo crudo / Raw thread / Fil brut / Rohes Baumwollfaden / Filo crudo
Q20	2	ø0,15x300	Hilo crudo / Raw thread / Fil brut / Rohes Baumwollfaden / Filo crudo
Q21	2	ø0,15x200	Hilo crudo / Raw thread / Fil brut / Rohes Baumwollfaden / Filo crudo
Q22	8	Preformado / Preformed/ Préformé / Vorgeformt / Preformato	Latón / Brass / Latón / Messing / Ottone
Q23	42	Preformado / Preformed/ Préformé / Vorgeformt / Preformato	Latón / Brass / Latón / Messing / Ottone
Q24	4	Preformado / Preformed/ Préformé / Vorgeformt / Preformato	Latón / Brass / Latón / Messing / Ottone
Q25	4	Preformado / Preformed/ Préformé / Vorgeformt / Preformato	Latón / Brass / Latón / Messing / Ottone
R1	2	Precortado / Precut / Prédécoupé / Vorgeschnitten / Pretagliatto / Pretagliatto	Tablero / Plywood / Planche / Sperrholz / Tavola
R2	4	Precortado / Precut / Prédécoupé / Vorgeschnitten / Pretagliatto / Pretagliatto	Tablero / Plywood / Planche / Sperrholz / Tavola
R3	2	Precortado / Precut / Prédécoupé / Vorgeschnitten / Pretagliatto / Pretagliatto	Tablero / Plywood / Planche / Sperrholz / Tavola
R4	24	Precortado / Precut / Prédécoupé / Vorgeschnitten / Pretagliatto / Pretagliatto	Tablero / Plywood / Planche / Sperrholz / Tavola
R5	2	Precortado / Precut / Prédécoupé / Vorgeschnitten / Pretagliatto / Pretagliatto	Tablero / Plywood / Planche / Sperrholz / Tavola
R6	4	0,6x5x215	Sapelly / Sapelli / Sapelli / Sapelly-Holz / Sapelli
R7	8	0,6x5x20	Sapelly / Sapelli / Sapelli / Sapelly-Holz / Sapelli
R8	2	1x3x195	Tilo / Lime wood / Tilleul / Linde / Tiglio
R9	8	1x3x15	Tilo / Lime wood / Tilleul / Linde / Tiglio
R10	14	ø0,50x125	Hilo marrón / Brown thread / Fil brun /braunes Baumwollfaden / Filo marrone

<i>Lista de piezas / Parts List / Liste des pièces / Teileliste / Elenco delle parti</i>			
Nº/No./ N° / Nr. No	Cantidad / Quantity / Quantité / Menge / Quantità	Medidas / Measurements / Dimensions / Maße / Misure	Material / Material / Matériau / Material / Materiale
R11	2	Precortado / Precut / Prédécoupé / Vorgeschnitten / Pretagliatto / Pretagliatto	Tablero / Plywood / Planche / Sperrholz / Tavola
R12	2	Precortado / Precut / Prédécoupé / Vorgeschnitten / Pretagliatto / Pretagliatto	Tablero / Plywood / Planche / Sperrholz / Tavola
R13	2	2x2x41	Tilo / Lime wood / Tilleul / Linde / Tiglio
R14	2	2x2x52	Tilo / Lime wood / Tilleul / Linde / Tiglio
R15	20	ø0,50x100	Hilo marrón / Brown thread / Fil brun /braunes Baumwollfaden / Filo marrone
R16	2	Preformado / Preformed/ Préformé / Vorgeformt / Preformato	Metal / Metal / Metal / Metall / Metallo
R17	8	Preformado / Preformed/ Préformé / Vorgeformt / Preformato	Metal / Metal / Metal / Metall / Metallo
S1	2	Preformado / Preformed/ Préformé / Vorgeformt / Preformato	Metal / Metal / Metal / Metall / Metallo
S2	2	Preformado / Preformed/ Préformé / Vorgeformt / Preformato	Metal / Metal / Metal / Metall / Metallo
S3	2	ø6	Latón / Brass / Latón / Messing / Ottone
S4	2	100	Latón / Brass / Latón / Messing / Ottone
S5	2	ø0,15x300mm	Hilo crudo / Raw thread / Fil brut / Rohes Baumwollfaden / Filo crudo
S6	4	ø0,50x100	Latón / Brass / Latón / Messing / Ottone
S7	18	Preformado / Preformed/ Préformé / Vorgeformt / Preformato	Cristal / Glass / Verre / Glas / Cristallo
S8	4	ø1x22	Latón / Brass / Latón / Messing / Ottone
S9	2	1x4x13	Tilo / Lime wood / Tilleul / Linde / Tiglio
S10	4	1x3x6	Tilo / Lime wood / Tilleul / Linde / Tiglio
S11	2	Precortado / Precut / Prédécoupé / Vorgeschnitten / Pretagliatto / Pretagliatto	Tablero / Plywood / Planche / Sperrholz / Tavola
S12-S23	24	Precortado / Precut / Prédécoupé / Vorgeschnitten / Pretagliatto / Pretagliatto	Tablero / Plywood / Planche / Sperrholz / Tavola
S24-S25	8	Precortado / Precut / Prédécoupé / Vorgeschnitten / Pretagliatto / Pretagliatto	Tablero / Plywood / Planche / Sperrholz / Tavola
S26	2	Precortado / Precut / Prédécoupé / Vorgeschnitten / Pretagliatto / Pretagliatto	Tablero / Plywood / Planche / Sperrholz / Tavola
S27-S37	22	Precortado / Precut / Prédécoupé / Vorgeschnitten / Pretagliatto / Pretagliatto	Tablero / Plywood / Planche / Sperrholz / Tavola
S38	8	Precortado / Precut / Prédécoupé / Vorgeschnitten / Pretagliatto / Pretagliatto	Tablero / Plywood / Planche / Sperrholz / Tavola
S39	2	Precortado / Precut / Prédécoupé / Vorgeschnitten / Pretagliatto / Pretagliatto	Tablero / Plywood / Planche / Sperrholz / Tavola
S40	2	Precortado / Precut / Prédécoupé / Vorgeschnitten / Pretagliatto / Pretagliatto	Tablero / Plywood / Planche / Sperrholz / Tavola
S41	48	1x3x120	Tilo / Lime wood / Tilleul / Linde / Tiglio
S42	10	1x3x75	Tilo / Lime wood / Tilleul / Linde / Tiglio
S43	6	1x3x55	Tilo / Lime wood / Tilleul / Linde / Tiglio
S44	8	1x4x20	Tilo / Lime wood / Tilleul / Linde / Tiglio
S45	8	1x4x17	Tilo / Lime wood / Tilleul / Linde / Tiglio
S46	2	Precortado / Precut / Prédécoupé / Vorgeschnitten / Pretagliatto / Pretagliatto	Tablero / Plywood / Planche / Sperrholz / Tavola
S47	2	Precortado / Precut / Prédécoupé / Vorgeschnitten / Pretagliatto / Pretagliatto	Tablero / Plywood / Planche / Sperrholz / Tavola
S48	2	Precortado / Precut / Prédécoupé / Vorgeschnitten / Pretagliatto / Pretagliatto	Tablero / Plywood / Planche / Sperrholz / Tavola
S49	2	Precortado / Precut / Prédécoupé / Vorgeschnitten / Pretagliatto / Pretagliatto	Tablero / Plywood / Planche / Sperrholz / Tavola
S50	2	2x2x75	Tilo / Lime wood / Tilleul / Linde / Tiglio
S51	2	2x2x58	Tilo / Lime wood / Tilleul / Linde / Tiglio
S52	2	Precortado / Precut / Prédécoupé / Vorgeschnitten / Pretagliatto / Pretagliatto	Tablero / Plywood / Planche / Sperrholz / Tavola
S53	2	Precortado / Precut / Prédécoupé / Vorgeschnitten / Pretagliatto / Pretagliatto	Tablero / Plywood / Planche / Sperrholz / Tavola
S54	8	ø0,15x300	Hilo crudo / Raw thread / Fil brut / Rohes Baumwollfaden / Filo crudo
S55	8	ø0,50x300	Hilo marrón / Brown thread / Fil brun /braunes Baumwollfaden / Filo marrone
T1	3	ø0,15x400	Hilo crudo / Raw thread / Fil brut / Rohes Baumwollfaden / Filo crudo
T2	6	ø0,15x400	Hilo marrón / Brown thread / Fil brun /braunes Baumwollfaden / Filo marrone
X-Y	2	Precortado / Precut / Prédécoupé / Vorgeschnitten / Pretagliatto	Tablero / Plywood / Planche / Sperrholz / Tavola
Z	2	Precortado / Precut / Prédécoupé / Vorgeschnitten / Pretagliatto	Tablero / Plywood / Planche / Sperrholz / Tavola

Lista de piezas / Parts List / Liste des pièces / Teileliste / Elenco delle parti

Nº/No./ N° / Nr. No	Descripción / Description / Description / Beschreibung / Descrizione	Cantidad / Quantity / Quantité / Menge / Quantità	Medidas / Measurements / Dimensions / Maße / Misure	Material / Material / Matériau / Material / Materiale
A		700	10	Metal / Metal / Metal / Metall / Metallo
B		110	15	Latón / Brass / Latón / Messing / Ottone
C		61	ø0,15x100	Hilo crudo / Raw thread / Fil brut / Rohes Baumwollfaden / Filo crudo
D		54	4	Composite / Composite / Composite / Composite / Composite
E		35	4	Composite / Composite / Composite / Composite / Composite
F		28	ø4	Composite / Composite / Composite / Composite / Composite
G		40	ø5	Composite / Composite / Composite / Composite / Composite
H		18	ø3	Latón / Brass / Laiton / Messing / Ottone
J		26	10	Composite / Composite / Composite / Composite / Composite

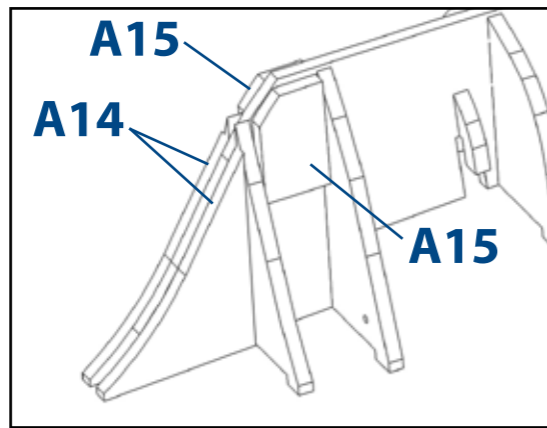

Accede a vídeos tutoriales fotografiando los códigos QR.
Access tutorial videos photographing QR codes.
Accédez aux didacticiels vidéo photographiant les codes QR.
Greifen Sie auf Video-Tutorials zu, die QR-Code fotografieren.
Accedi ai video tutorial fotografando i codici QR.
Доступ к видеоурокам фотографирования QR-кодов.

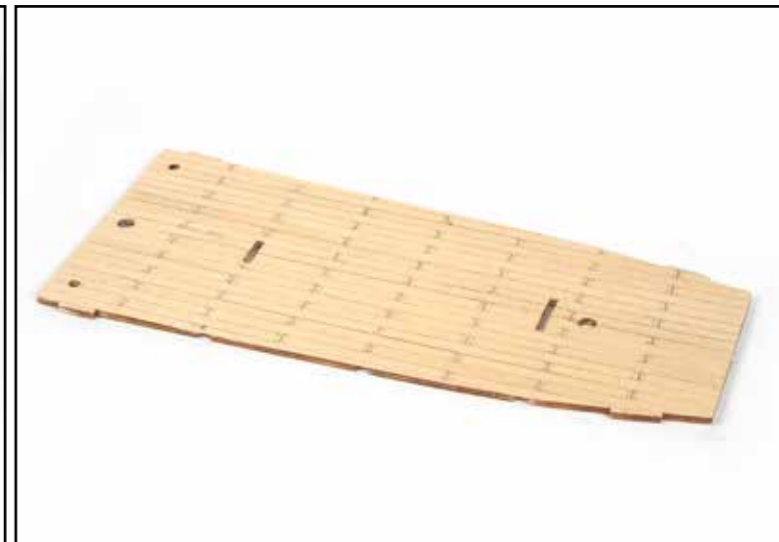
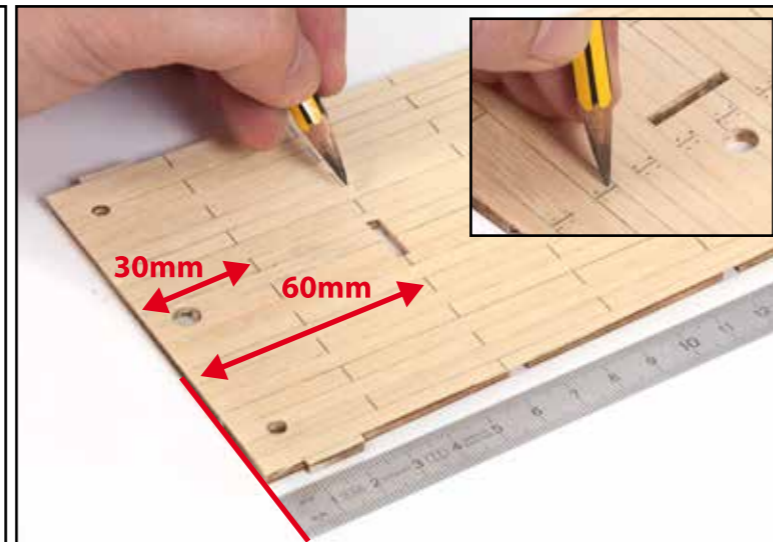
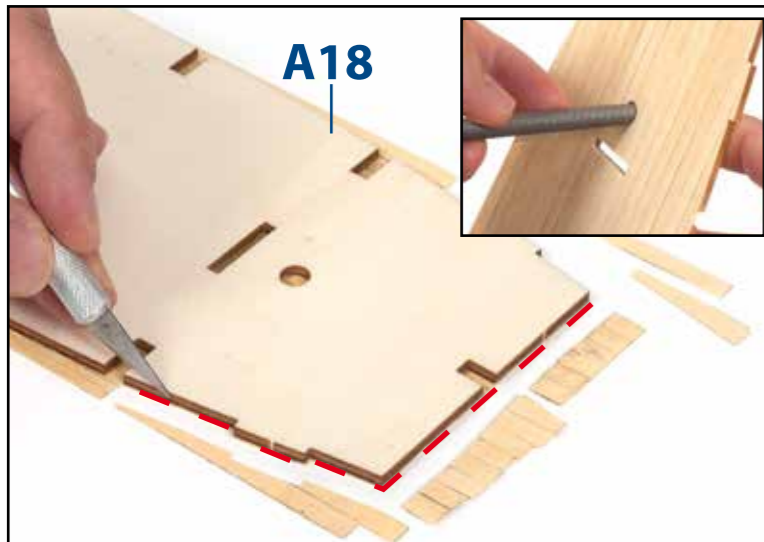
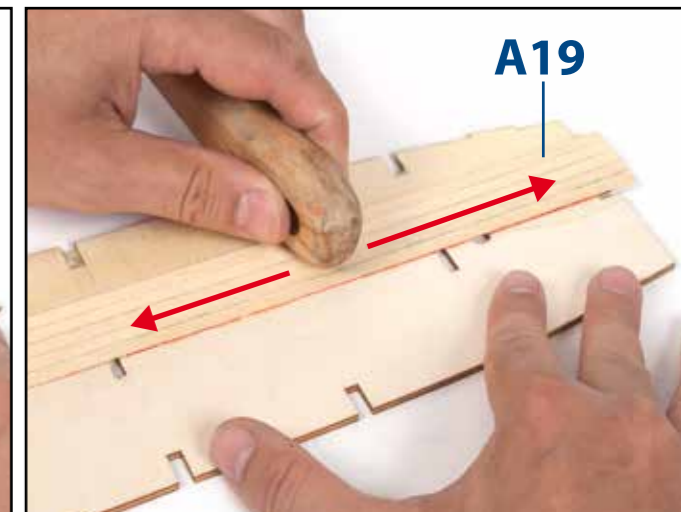
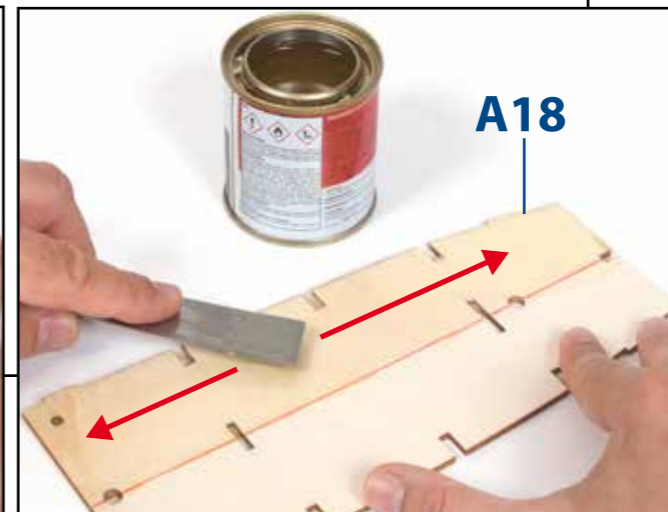
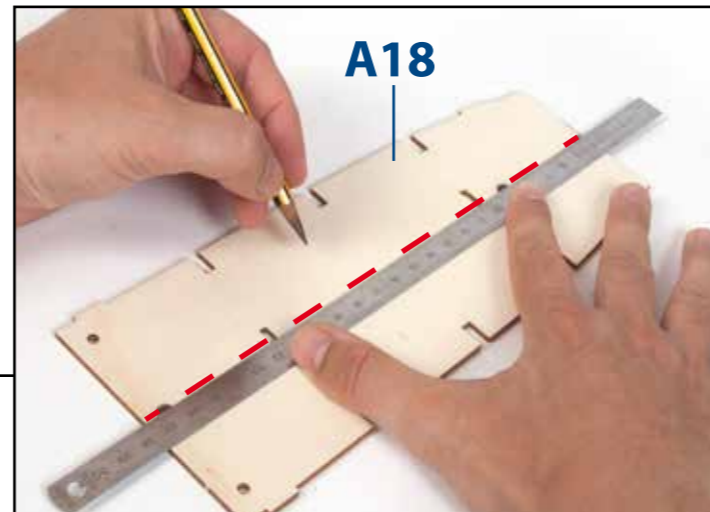
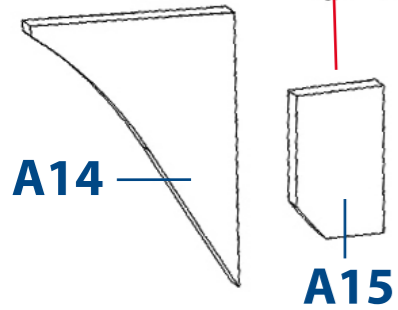
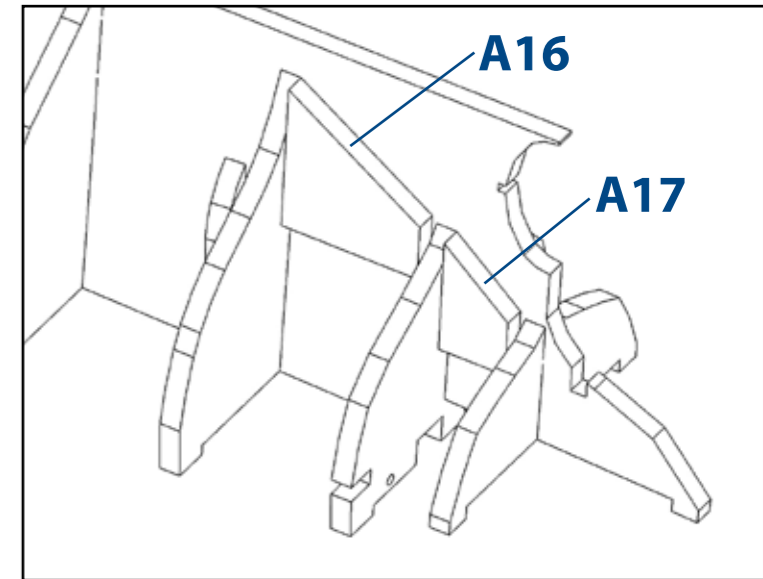
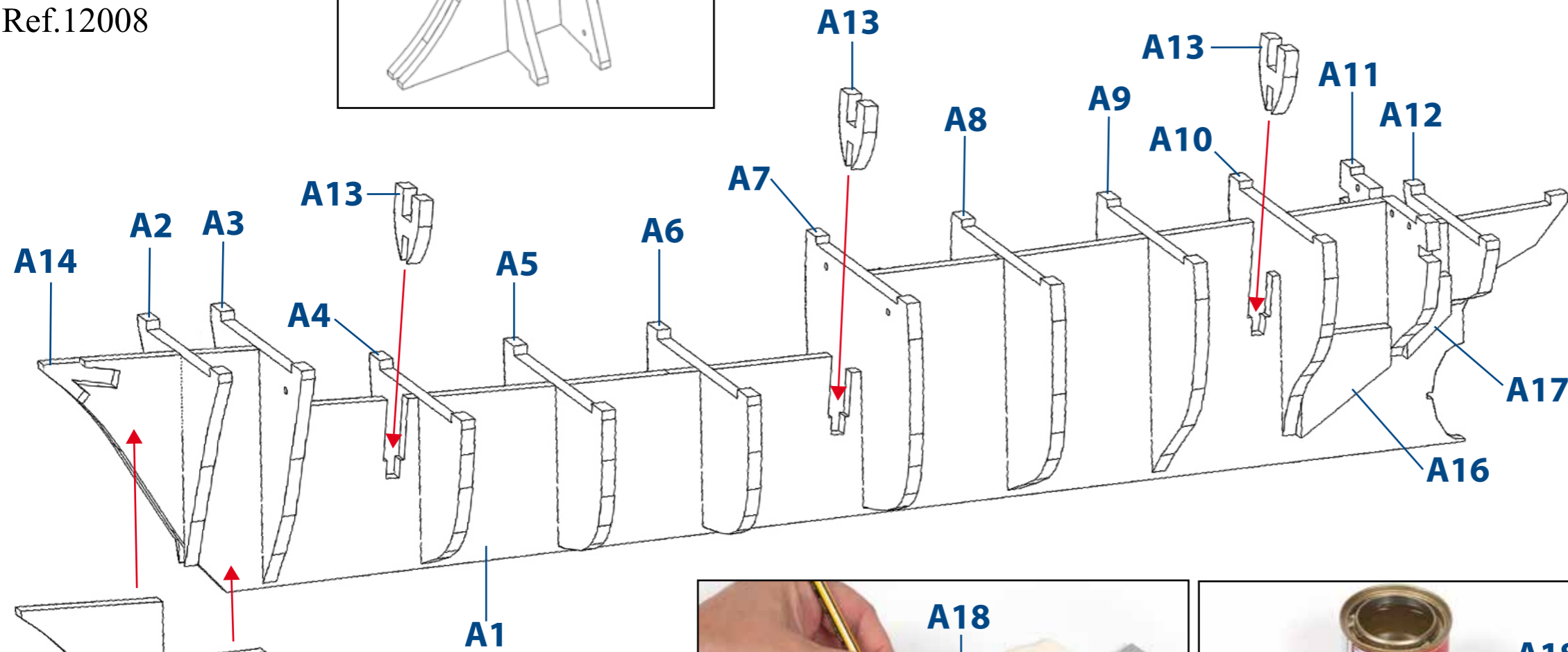

B

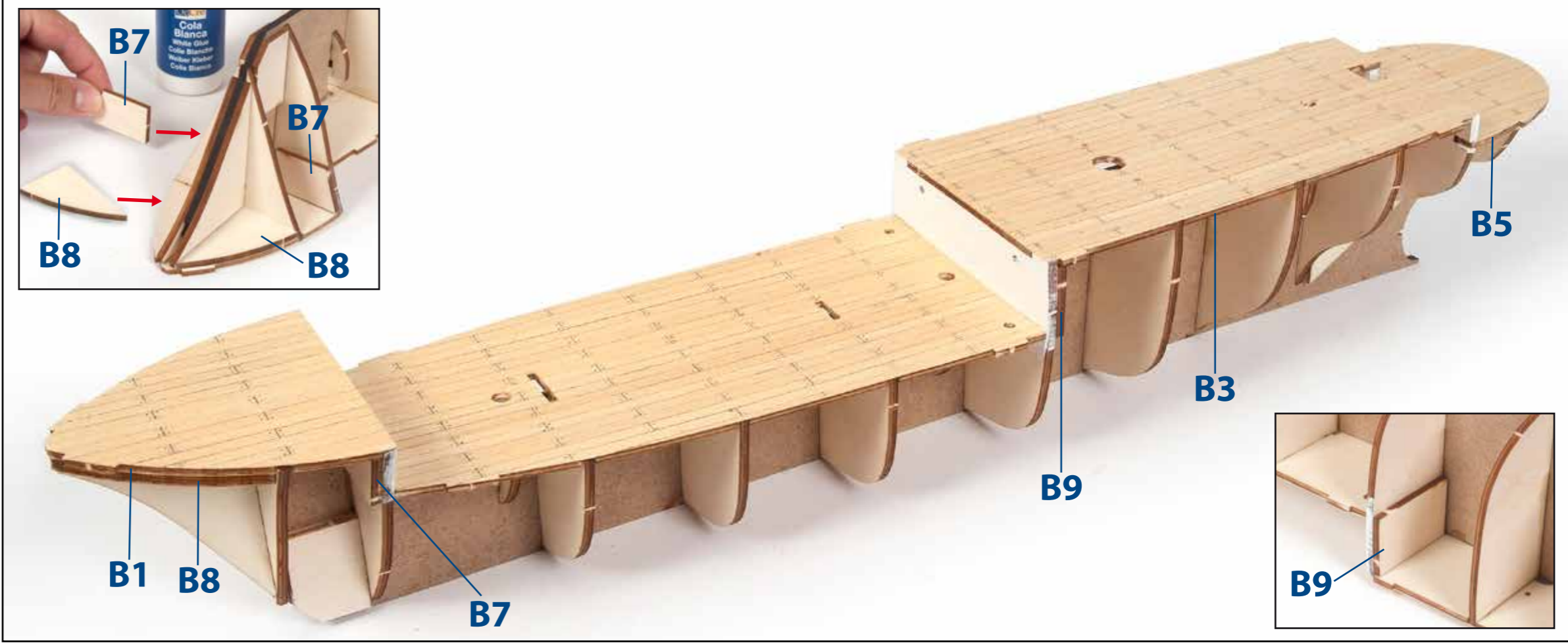
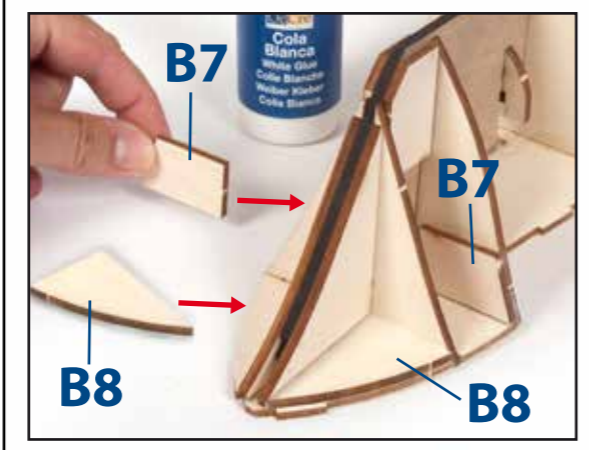
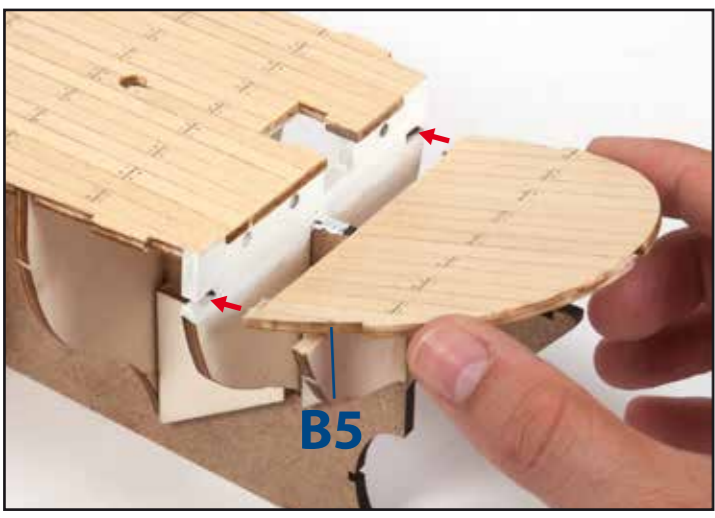
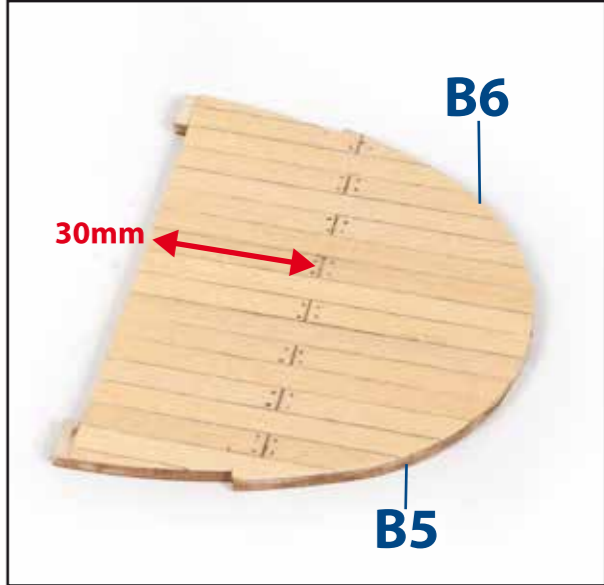
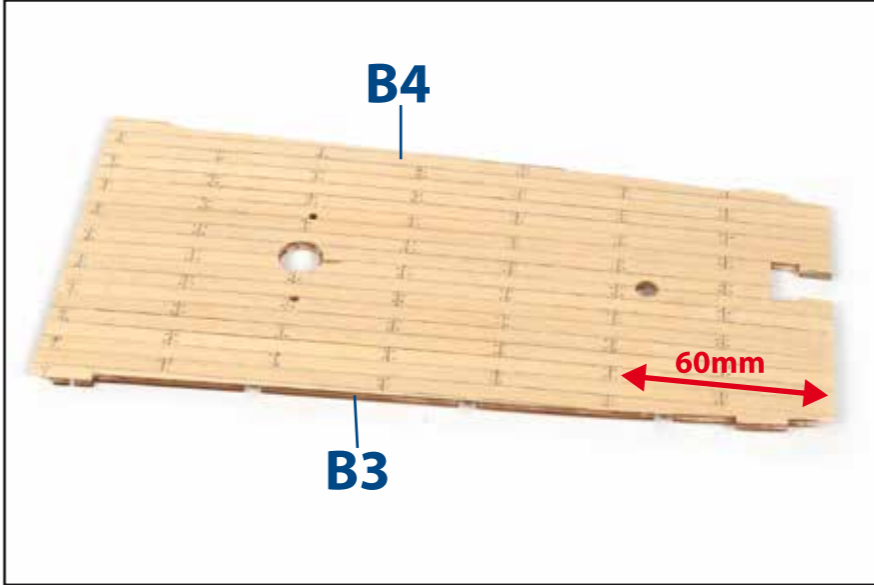
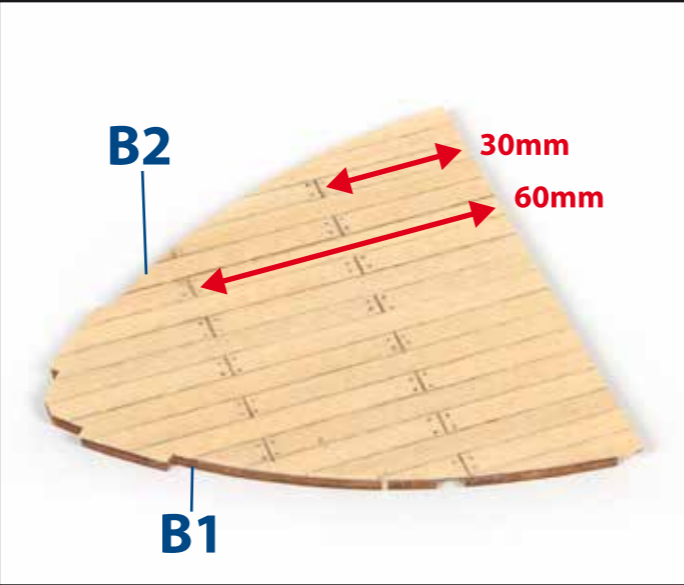
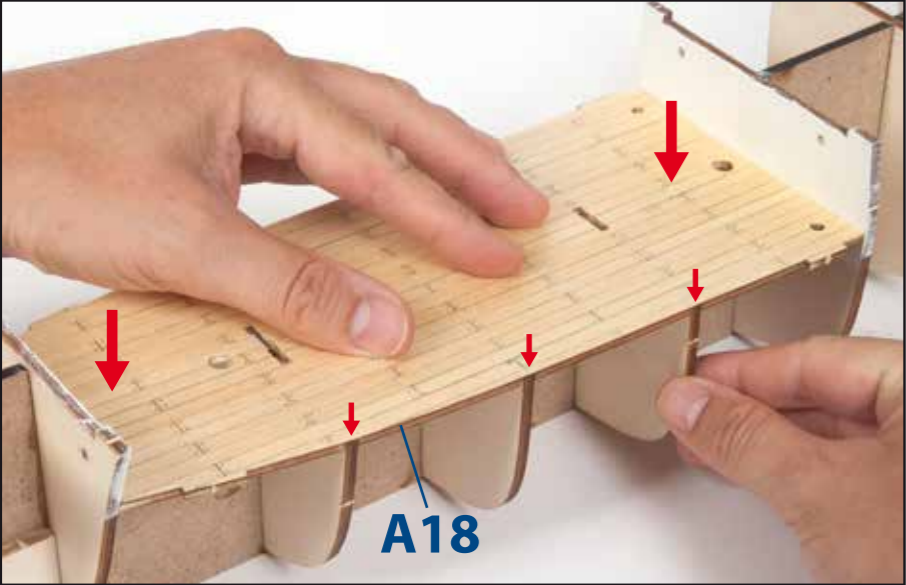
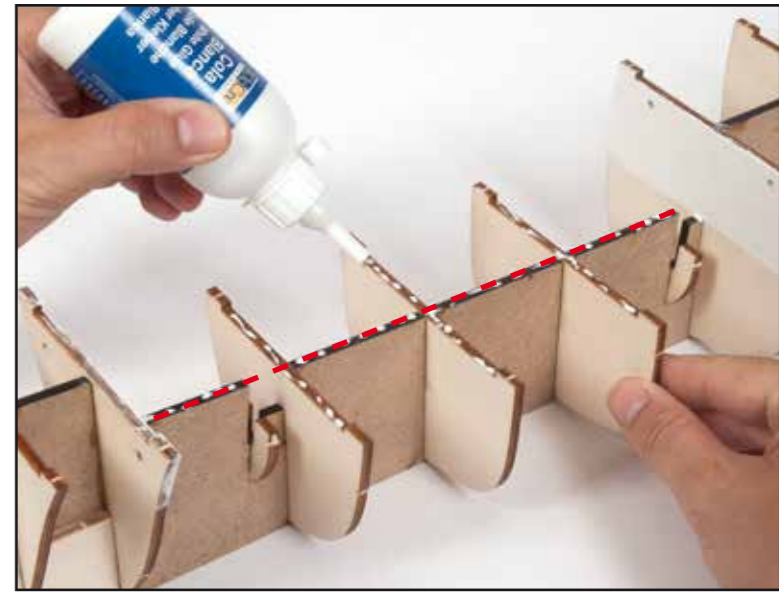
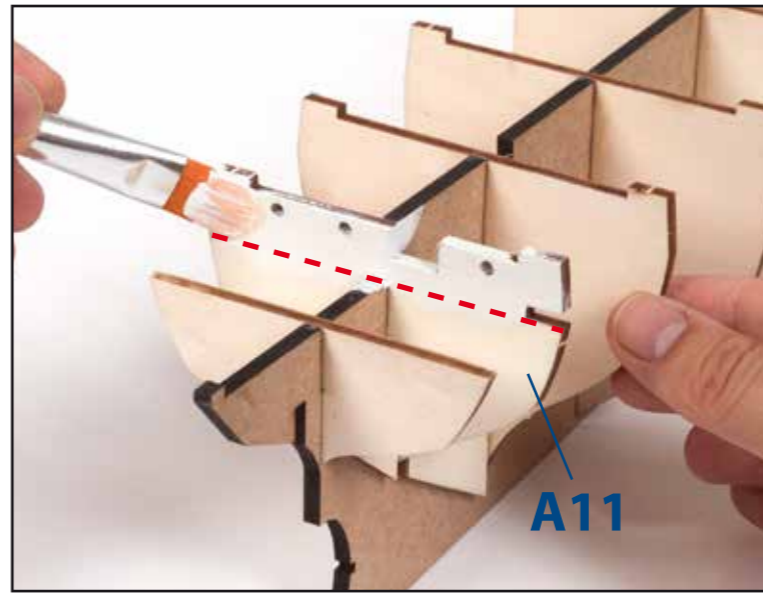
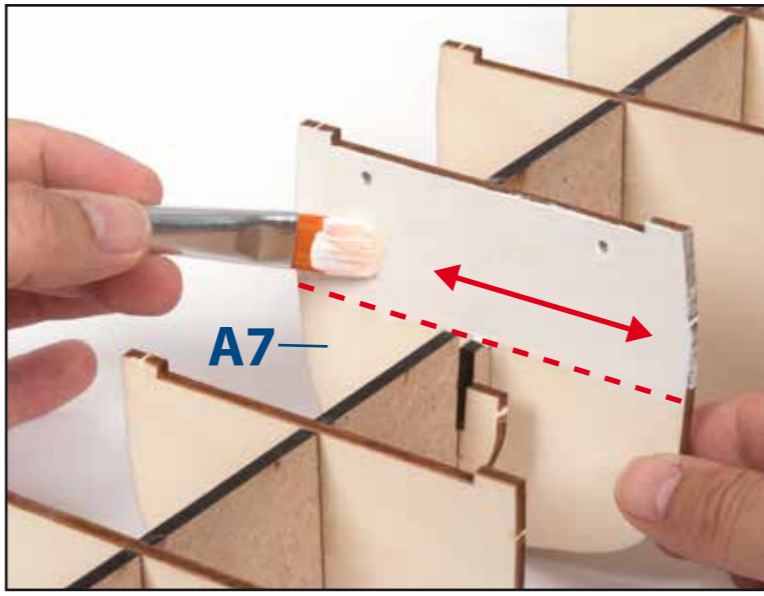
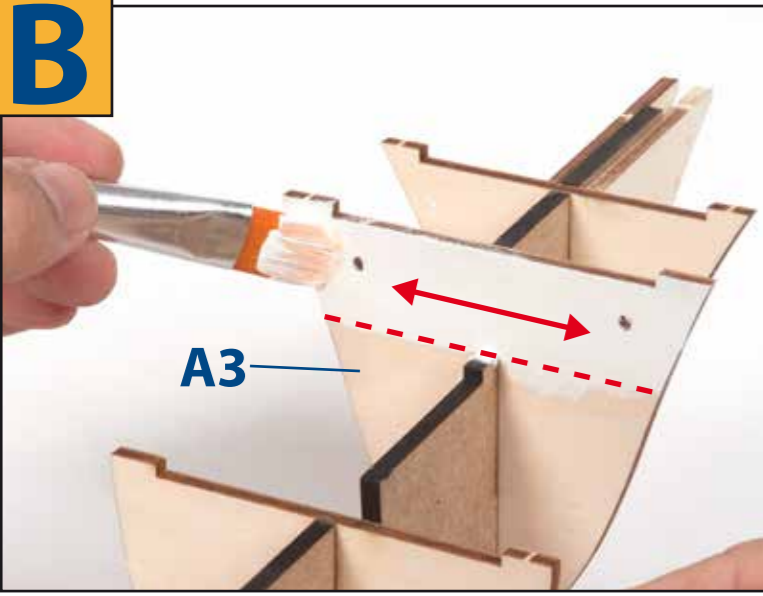

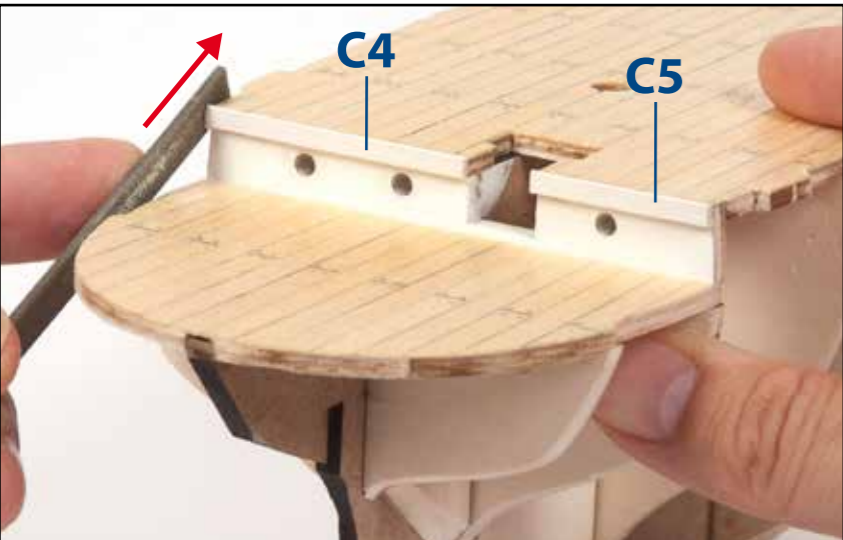
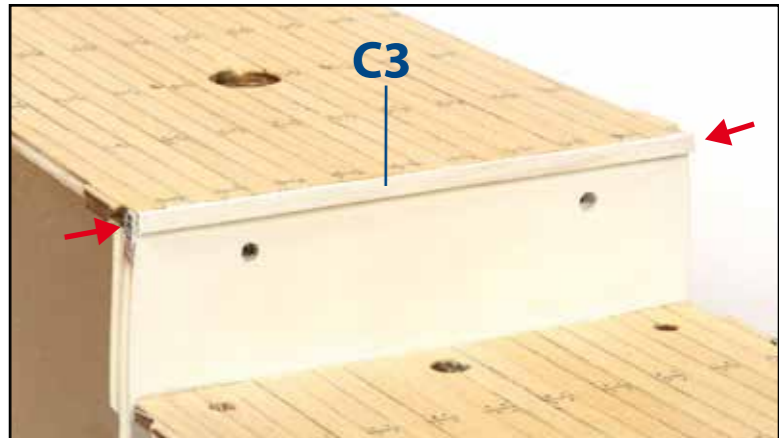
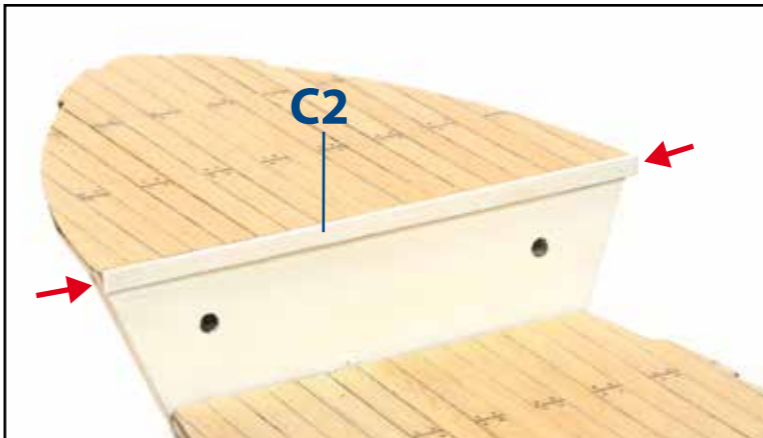
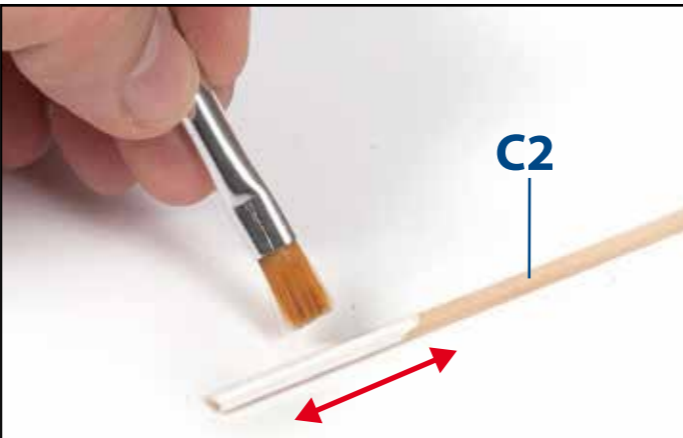
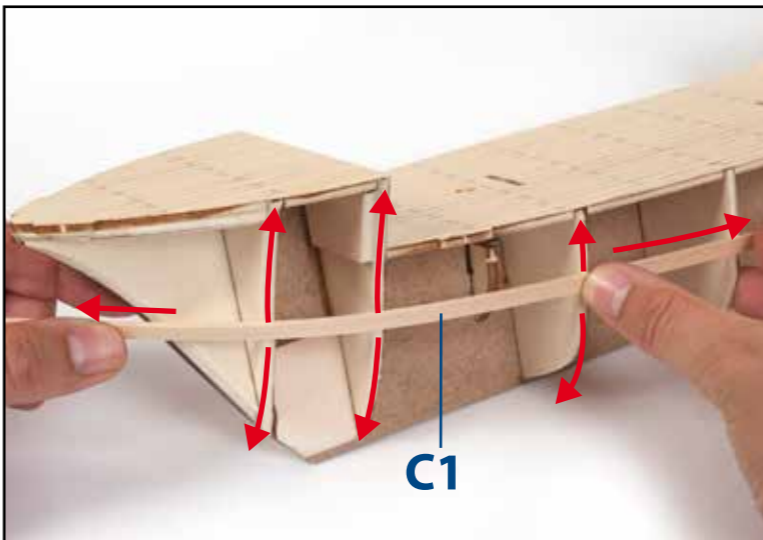
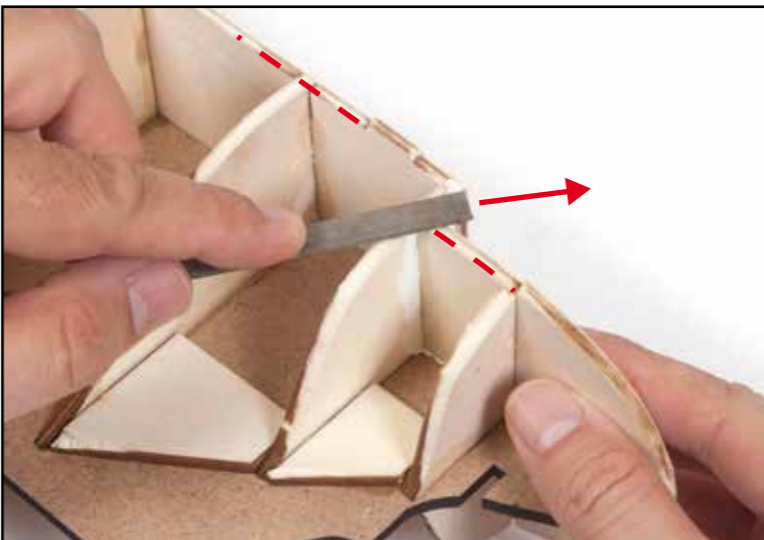
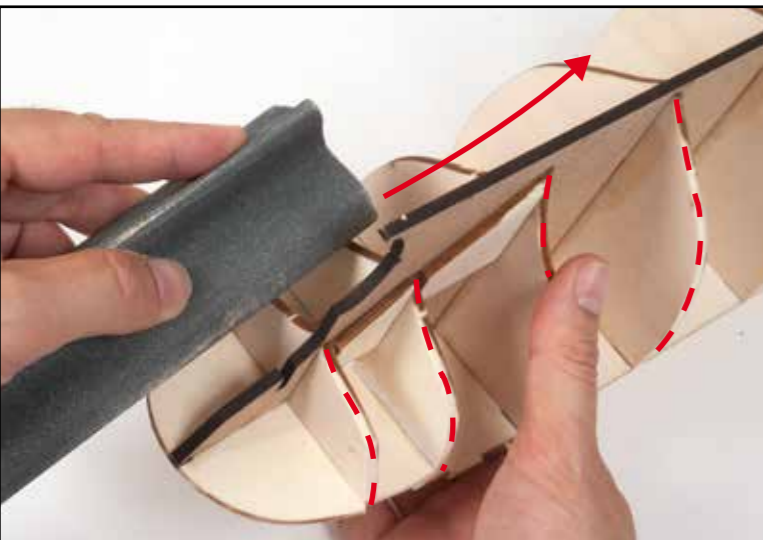
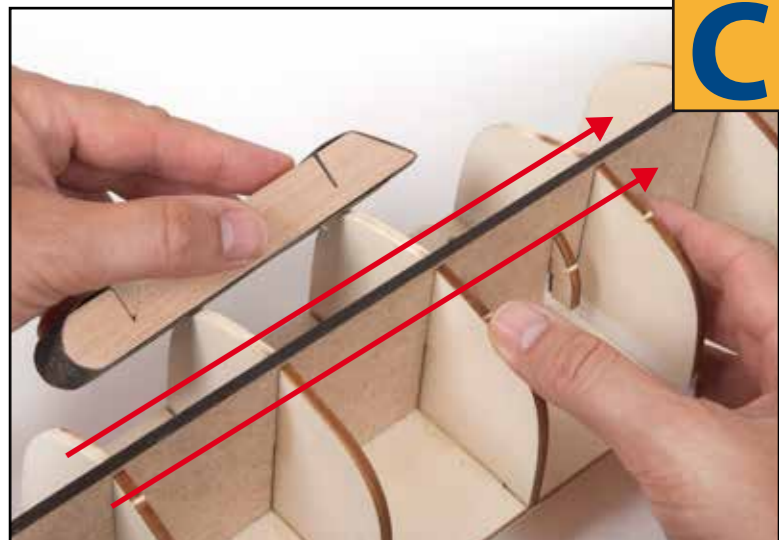
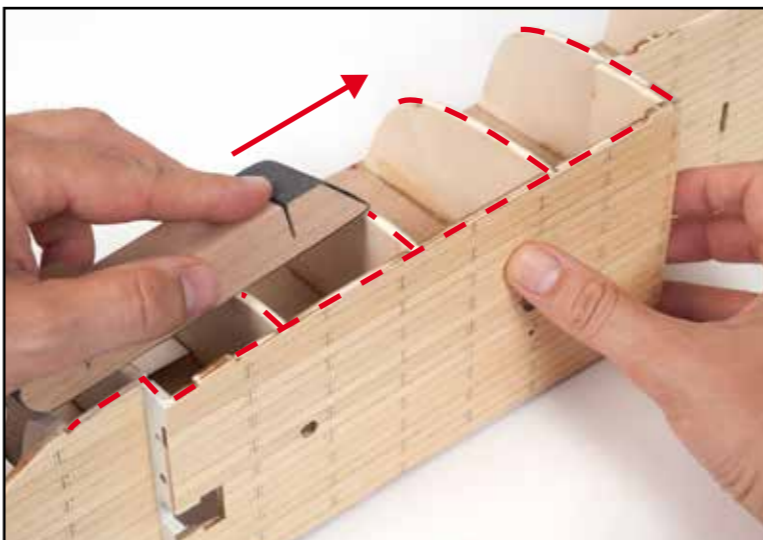
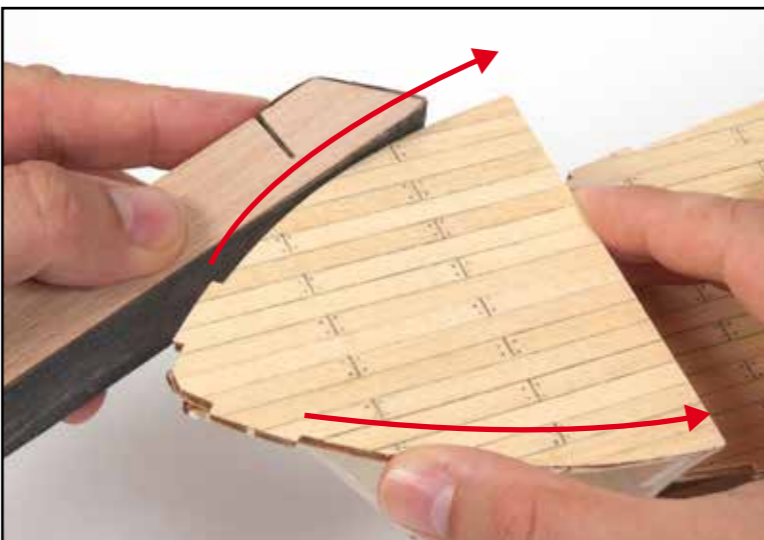
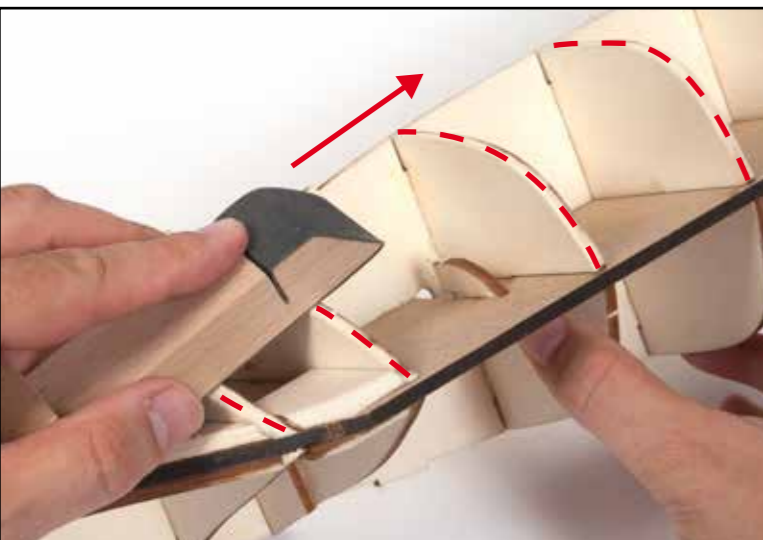

D

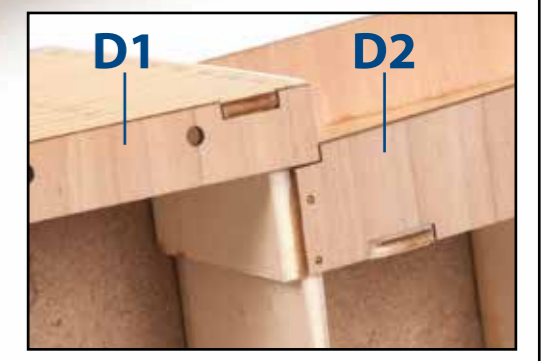
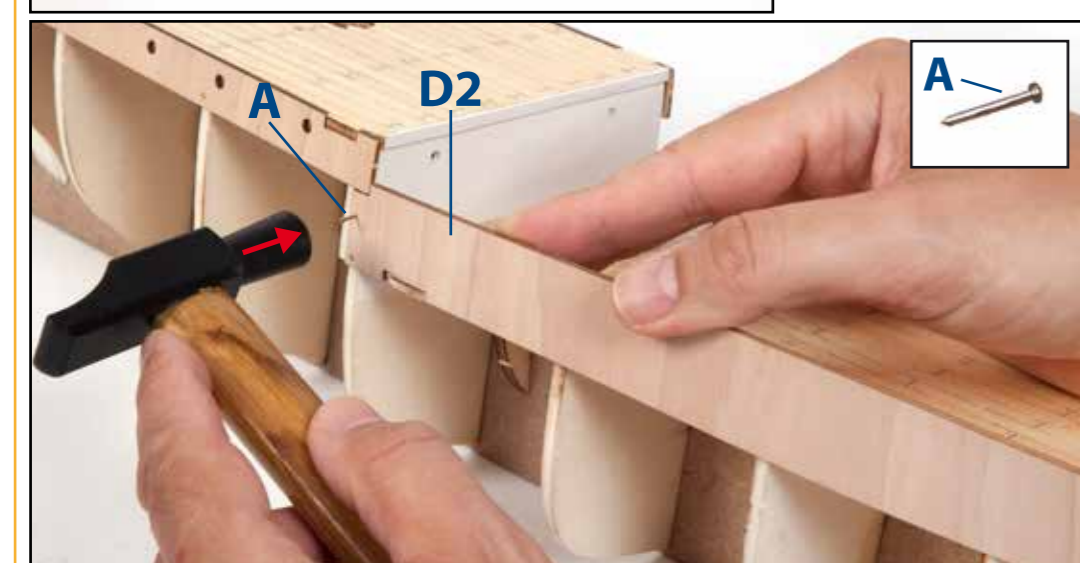
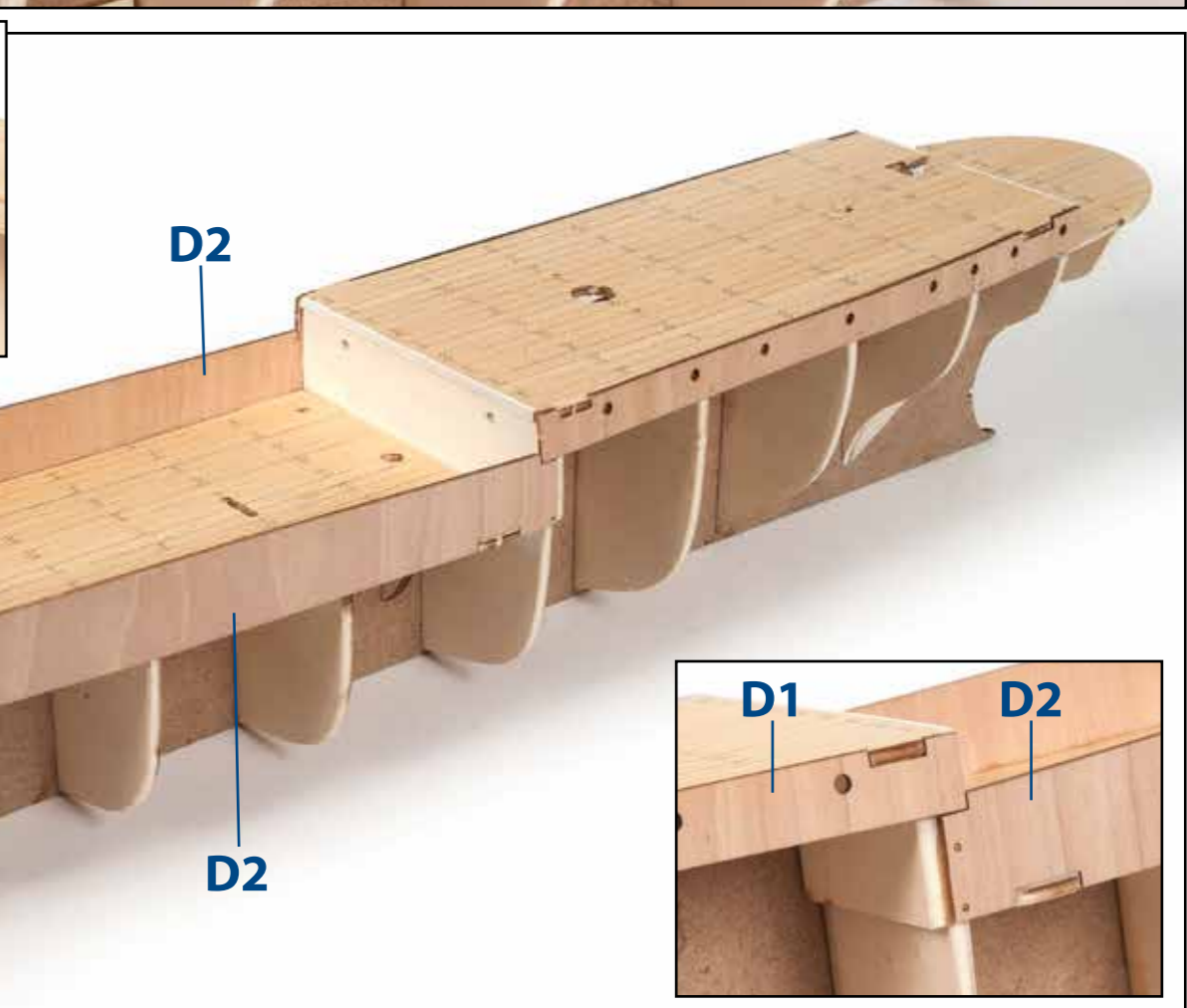
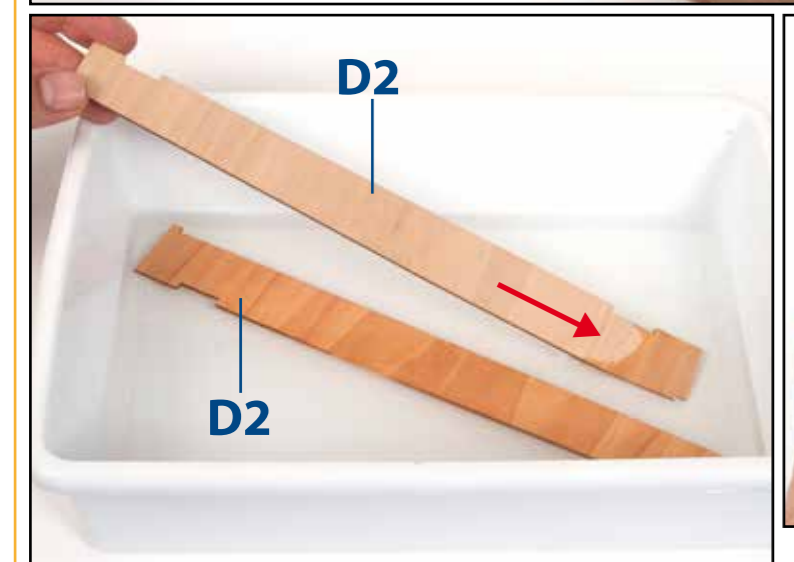
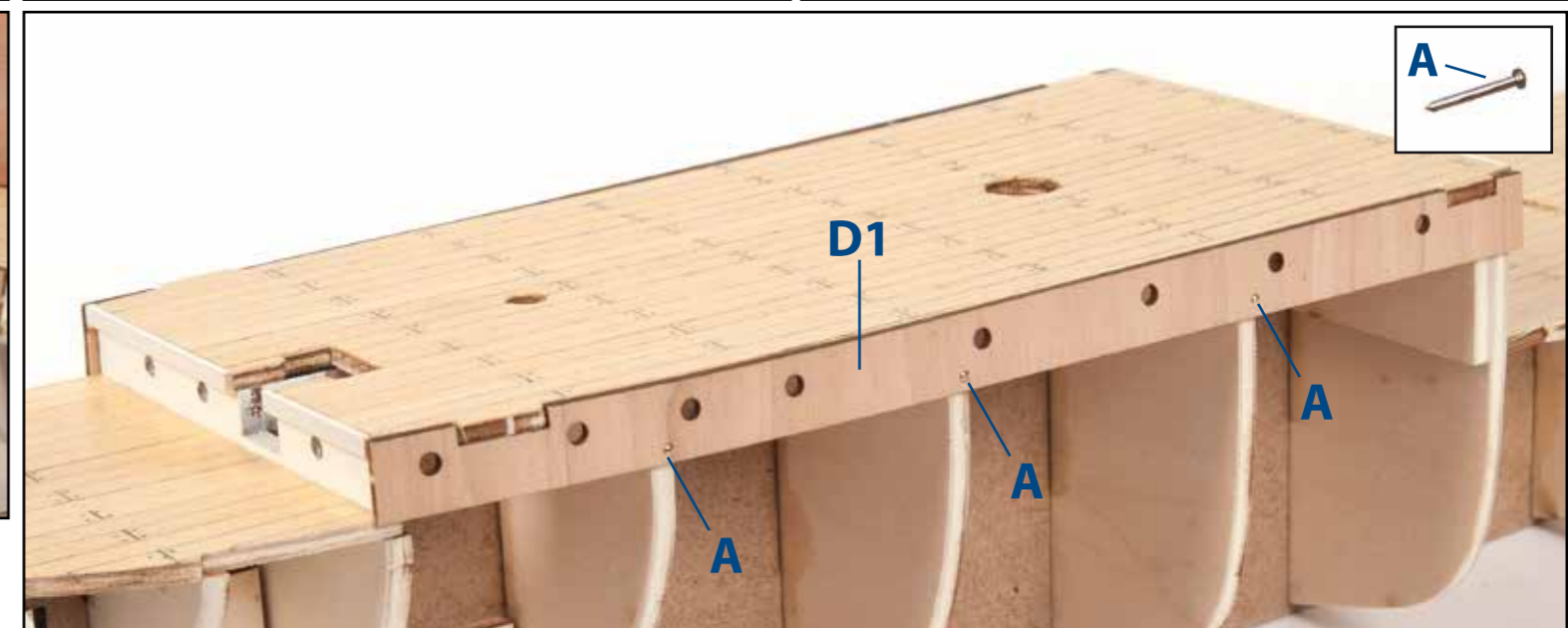
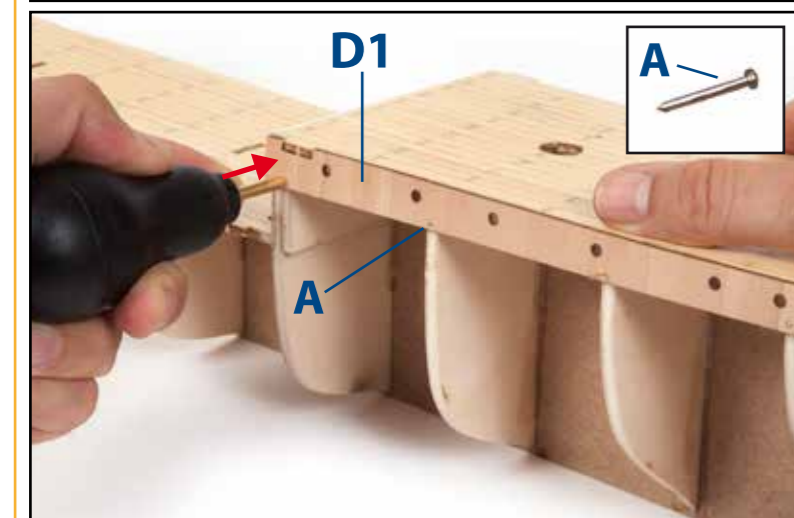
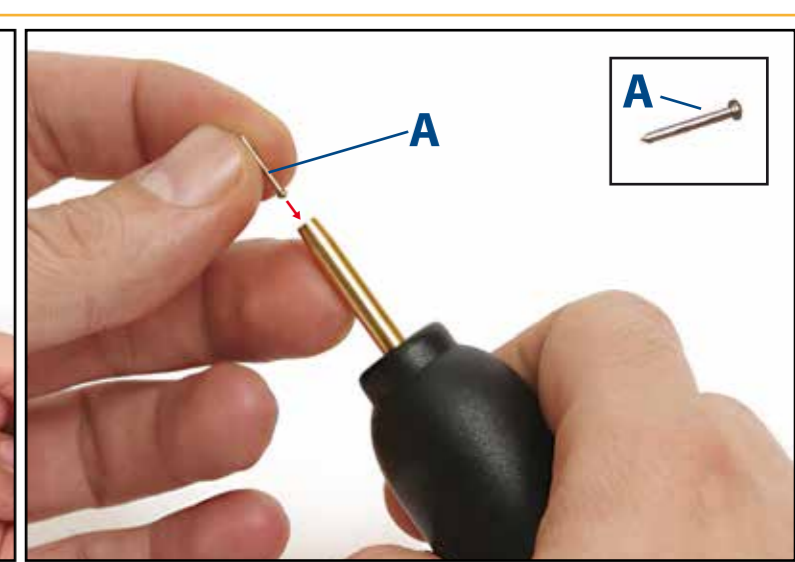
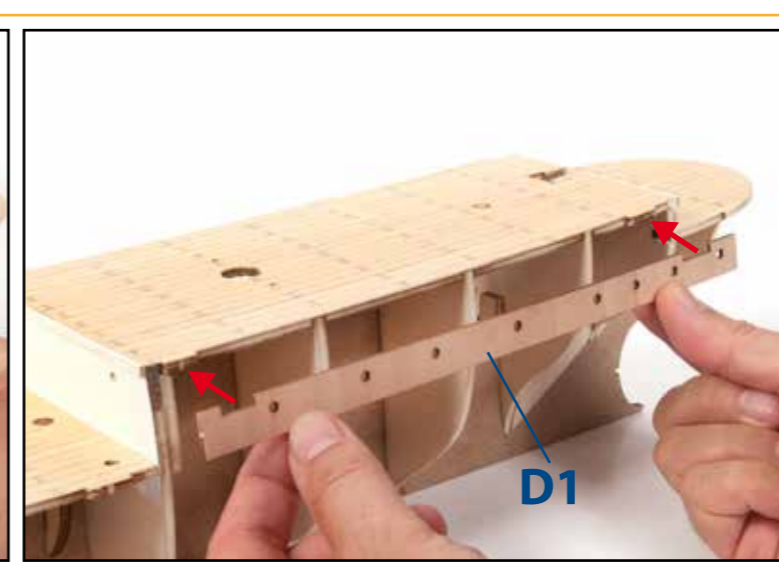
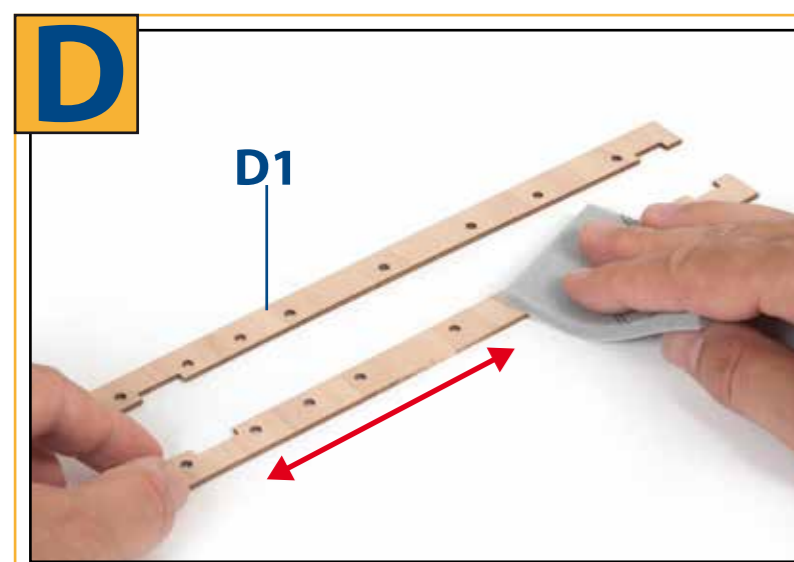

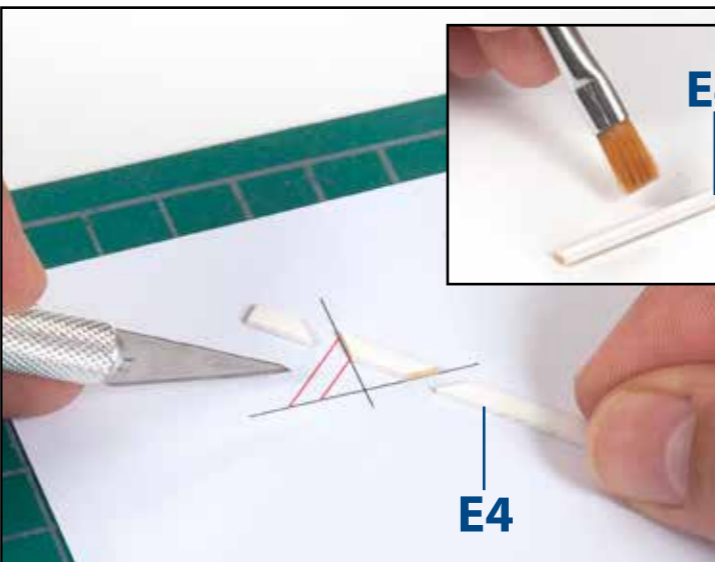
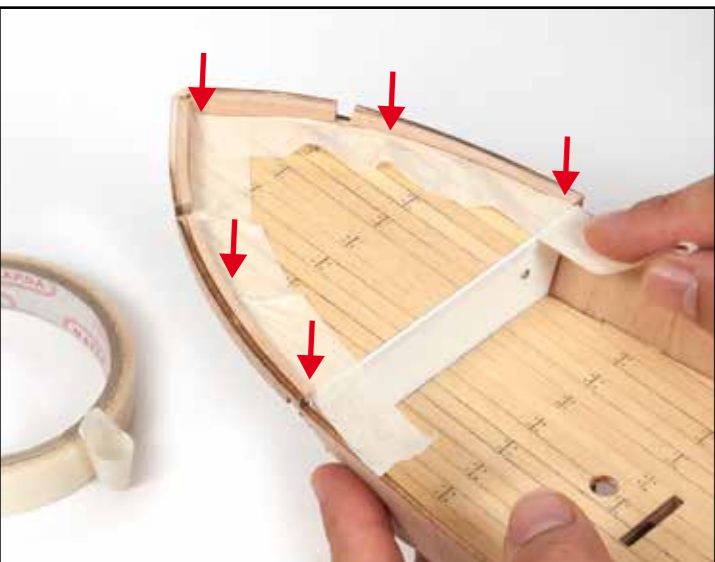
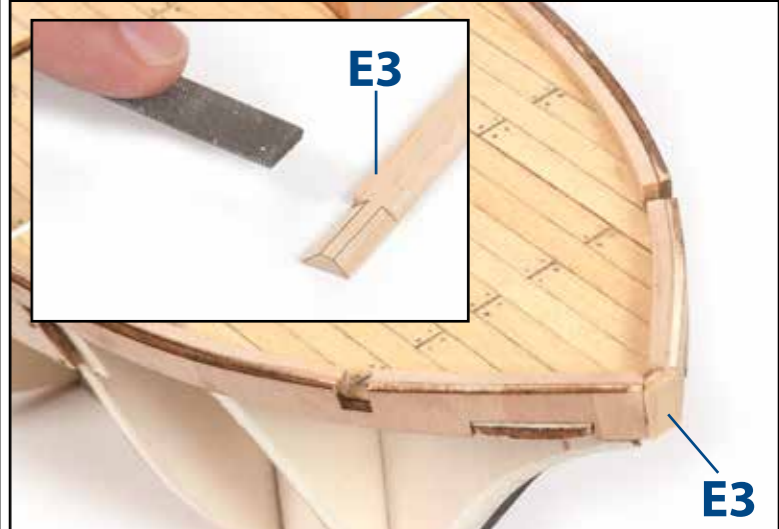
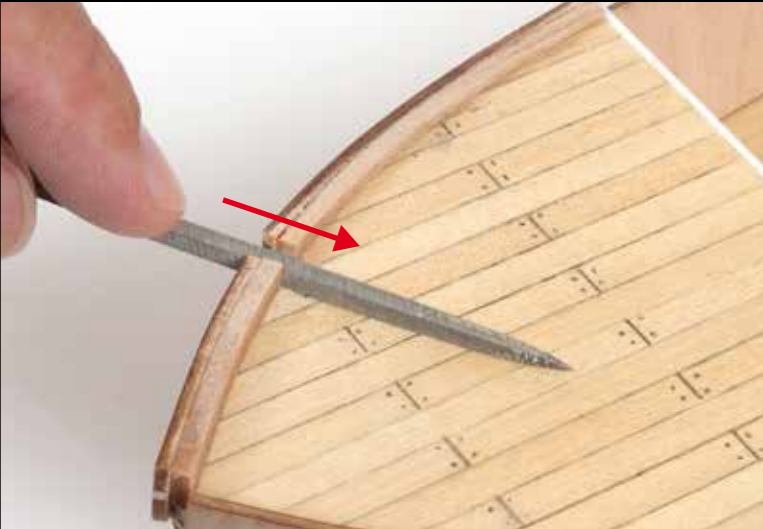
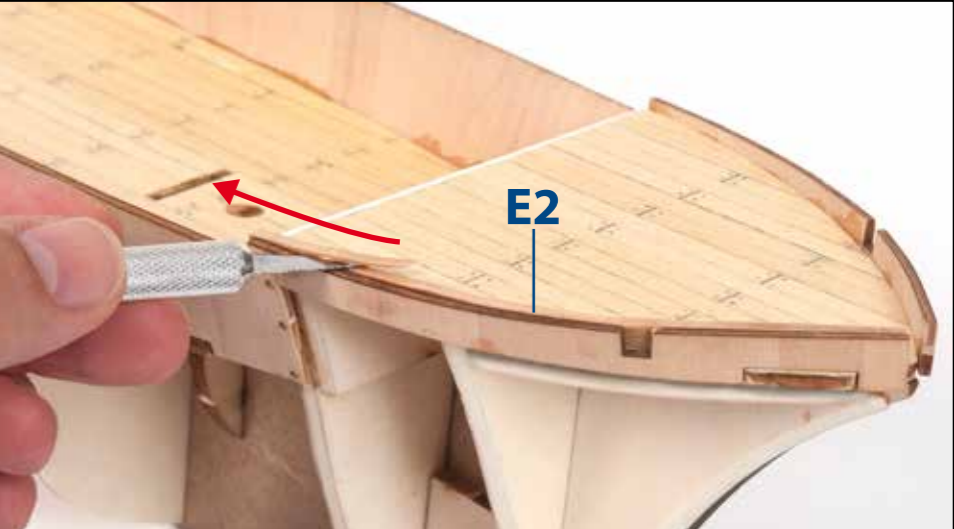
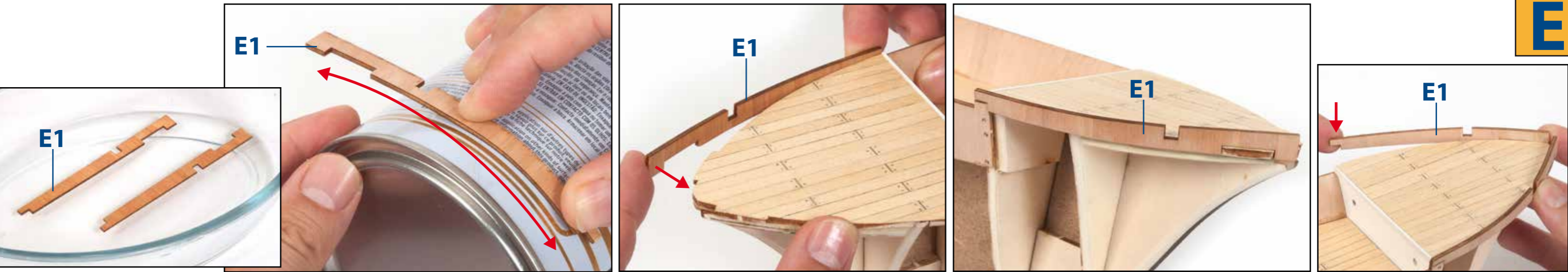

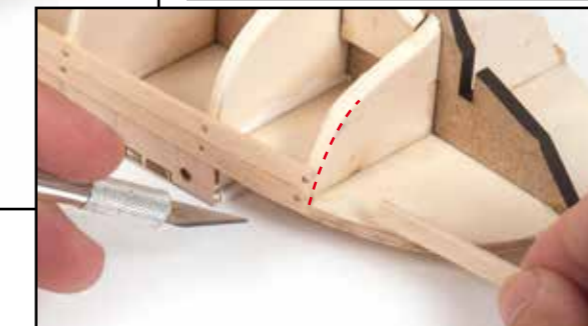
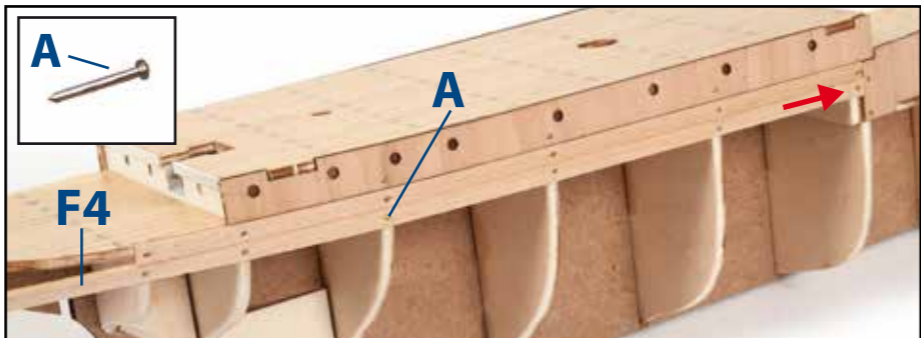
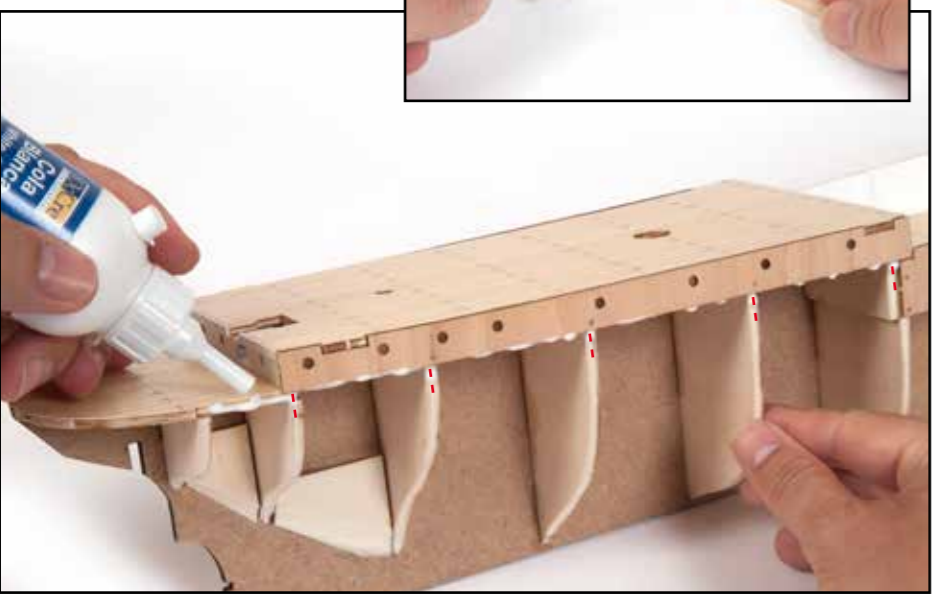
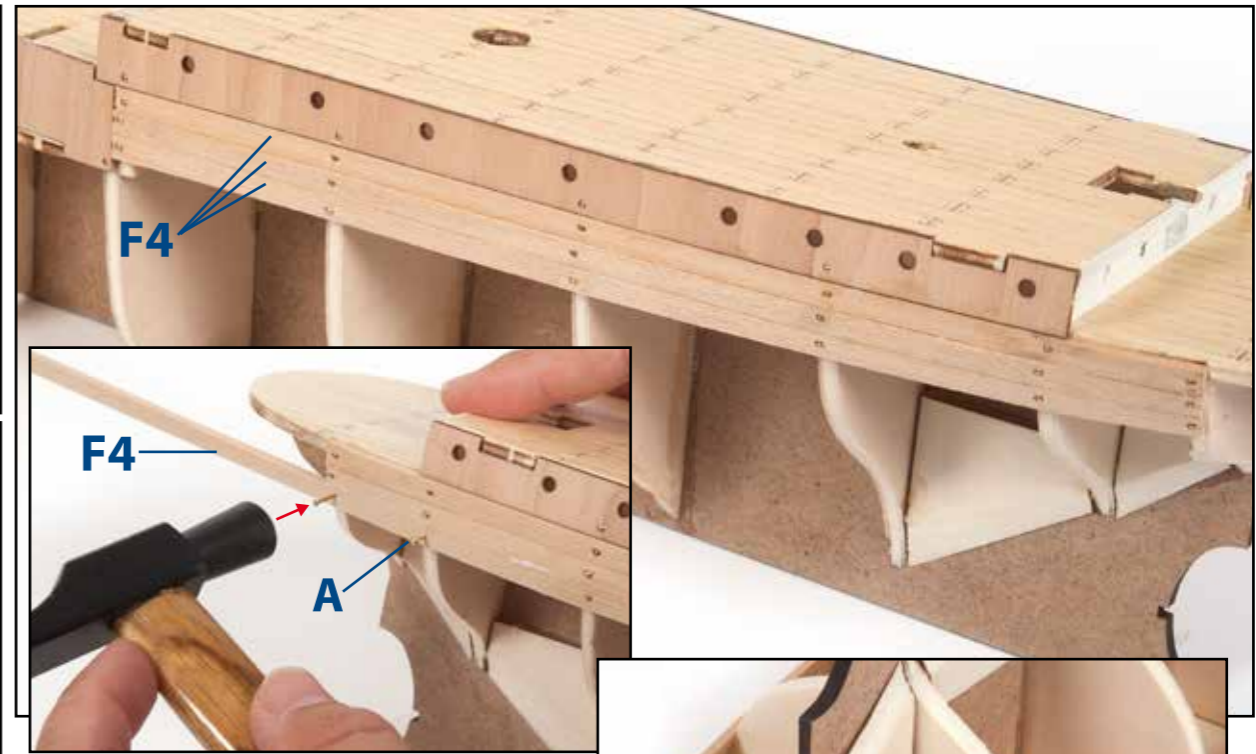
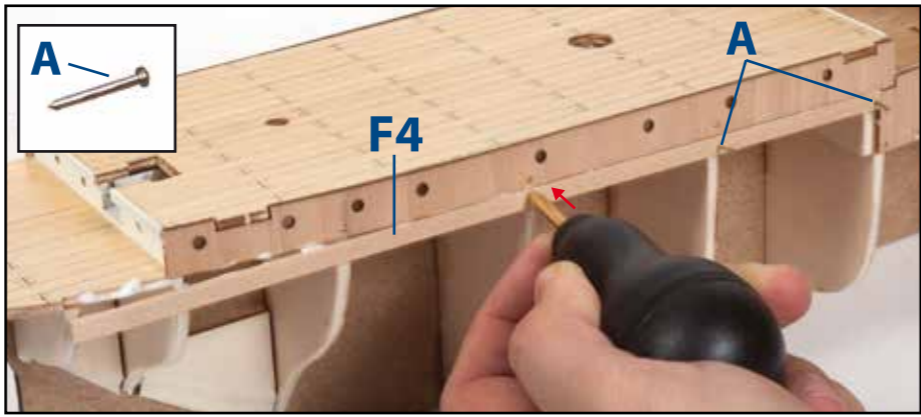
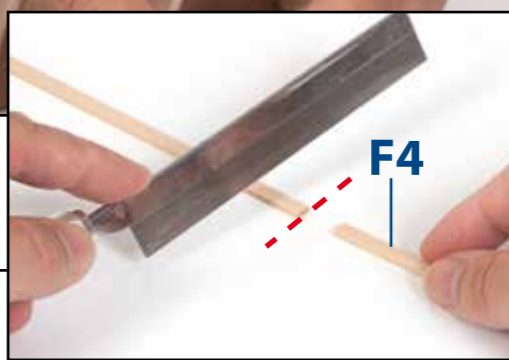
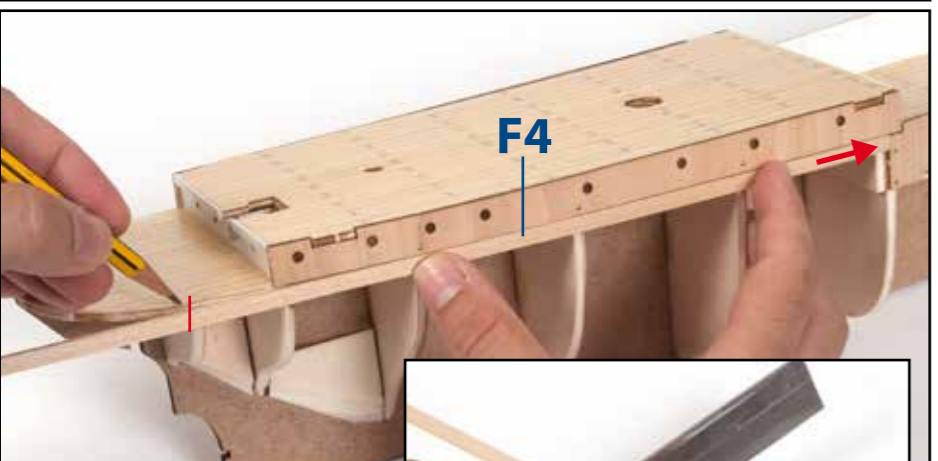
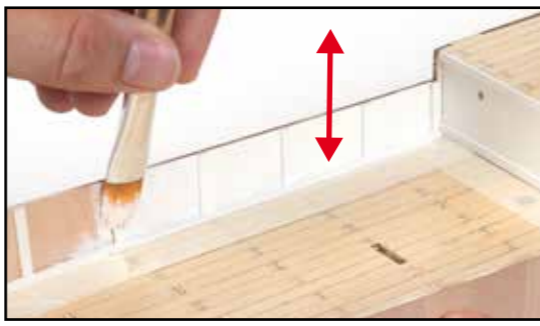
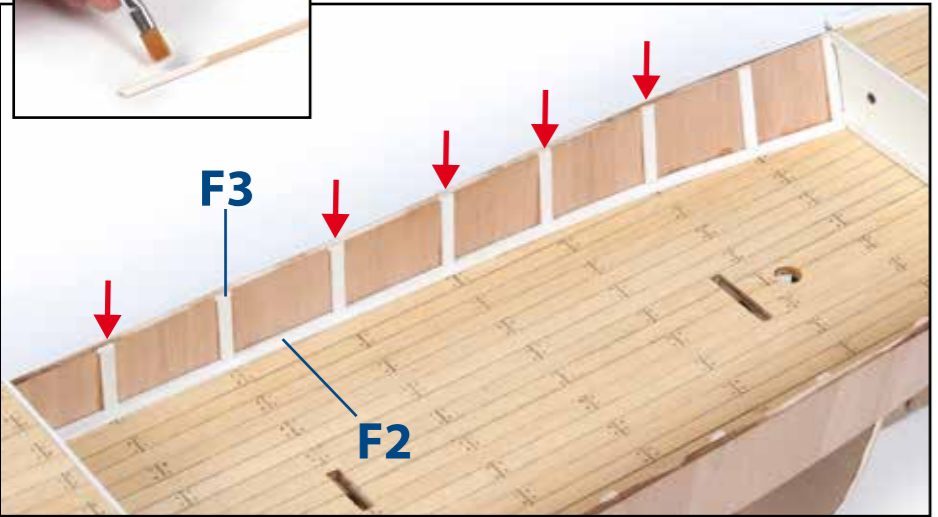
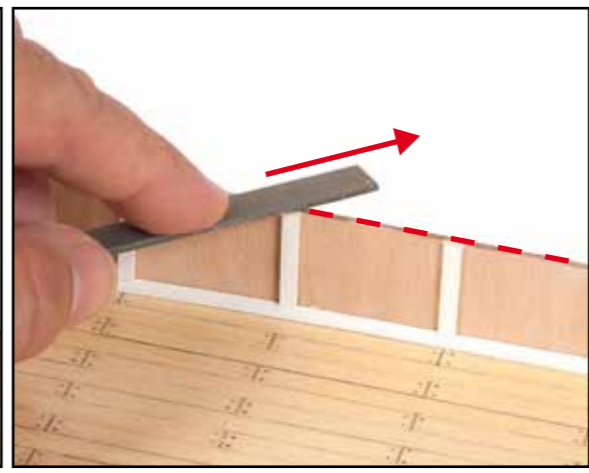
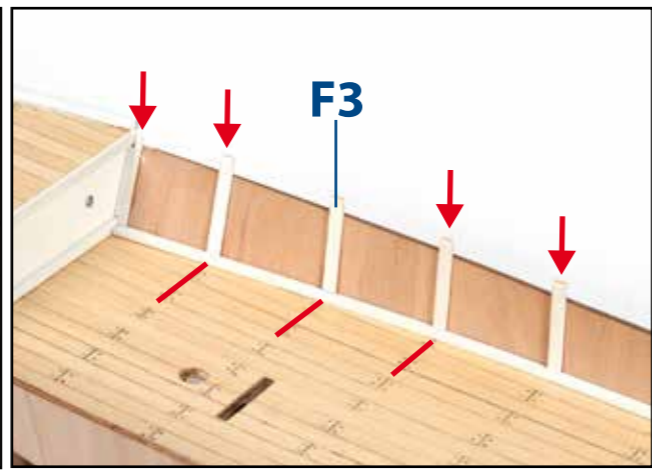
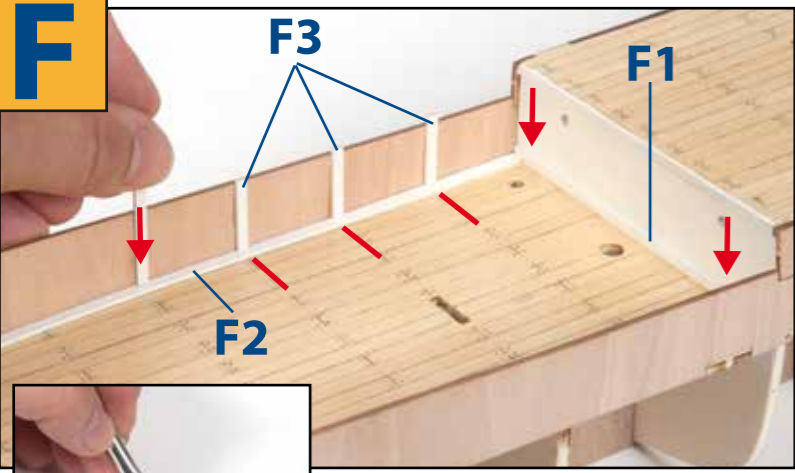
F

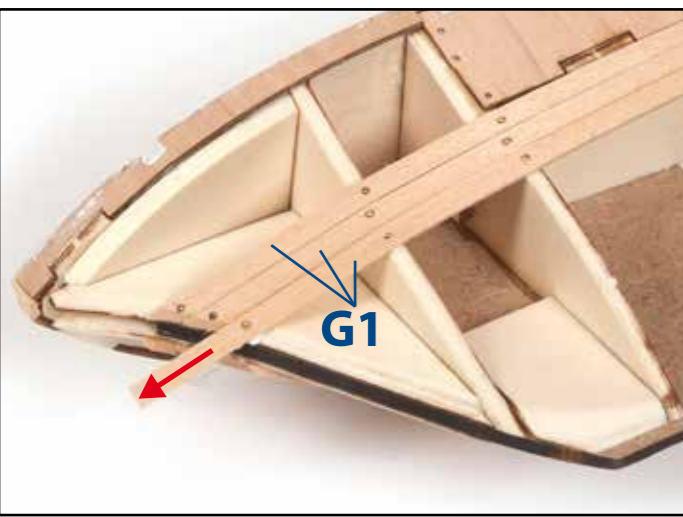
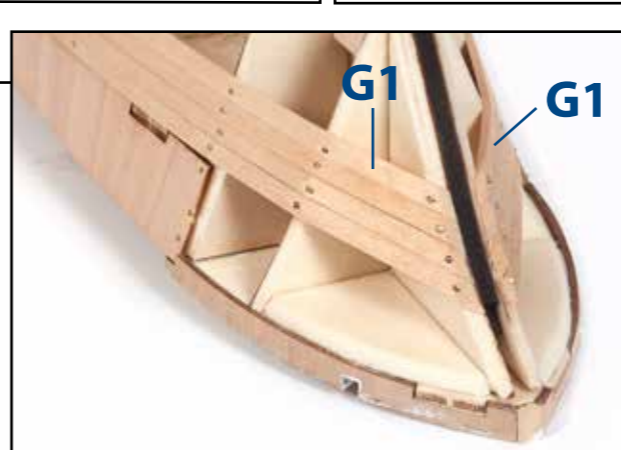
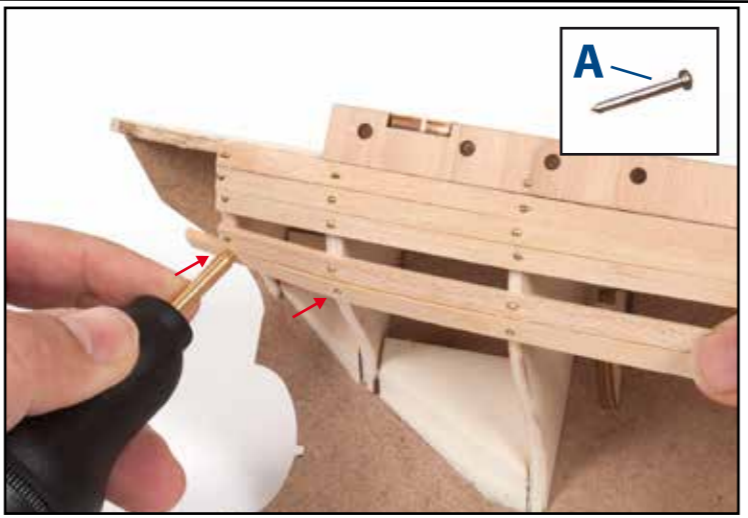
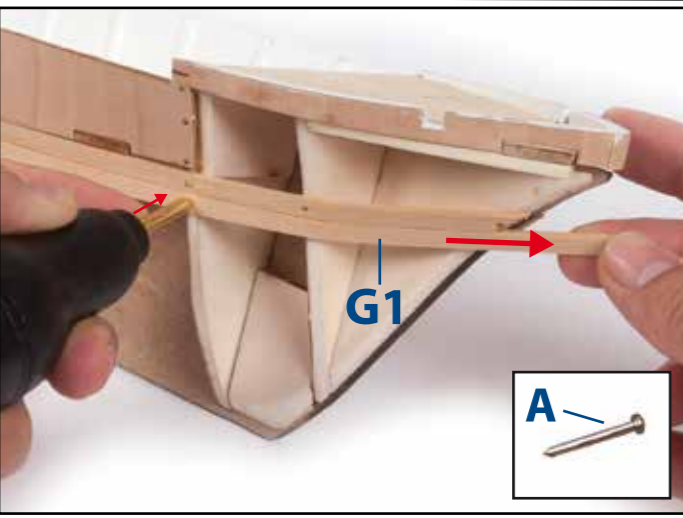
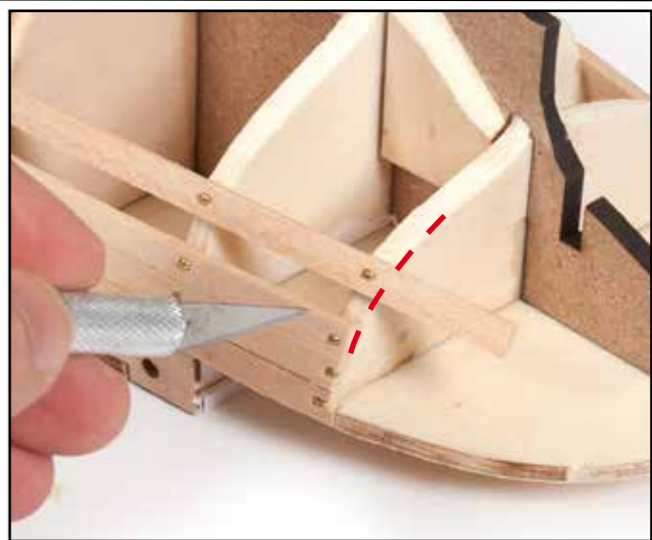
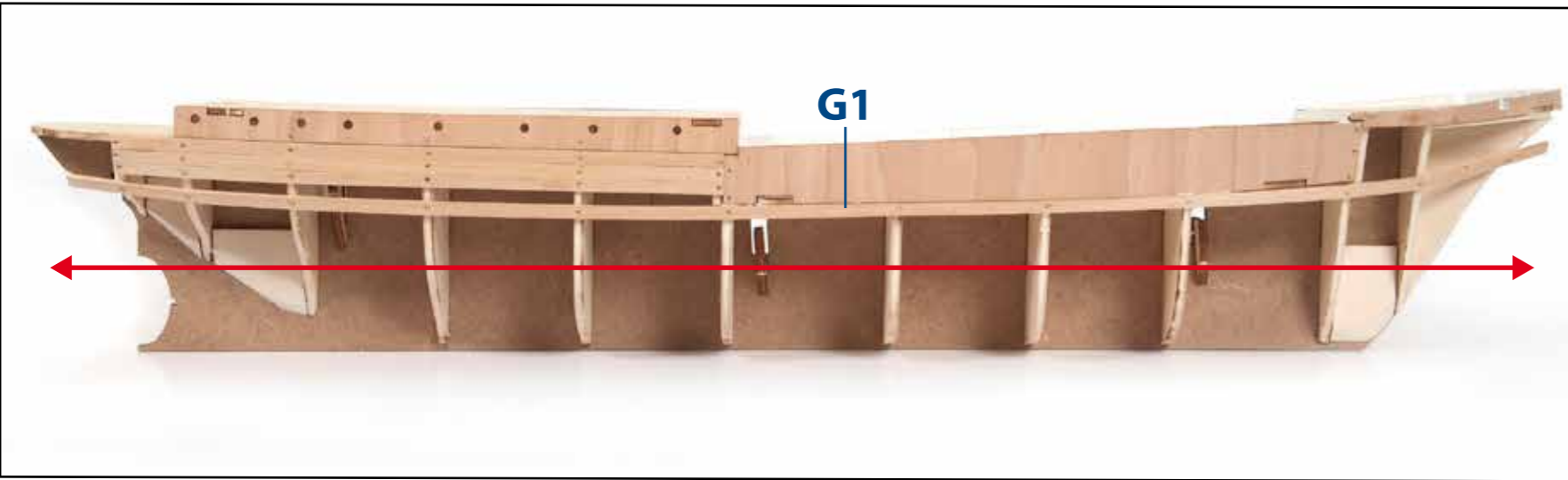
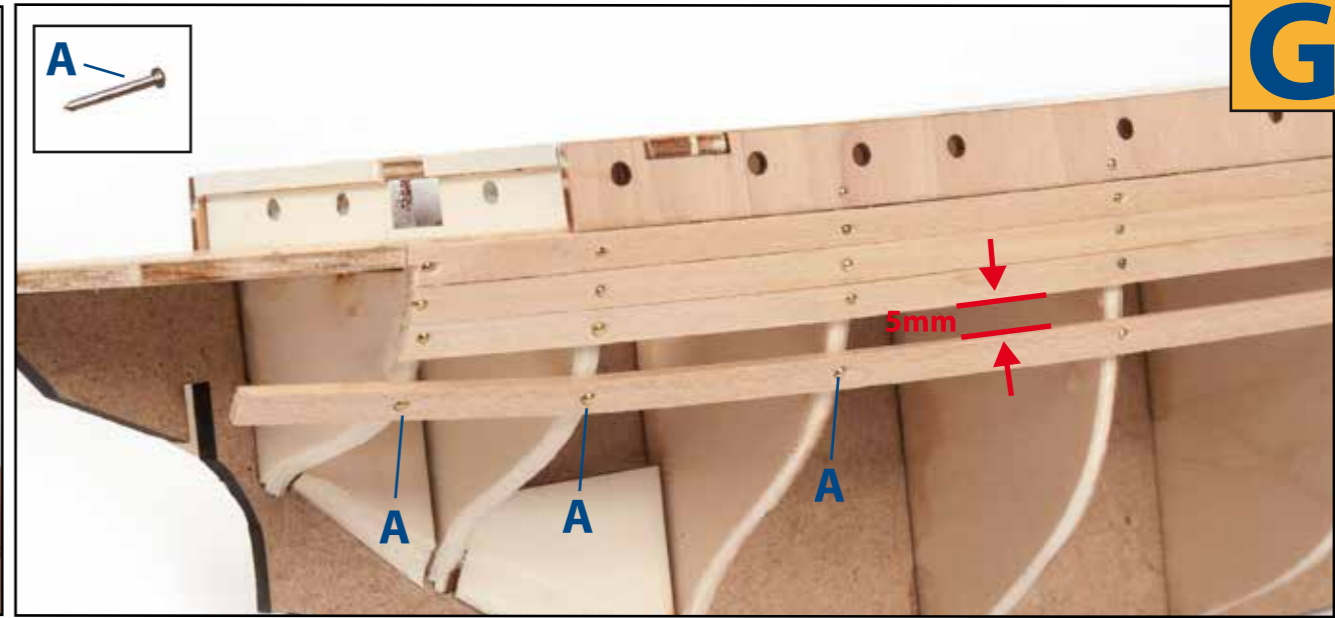

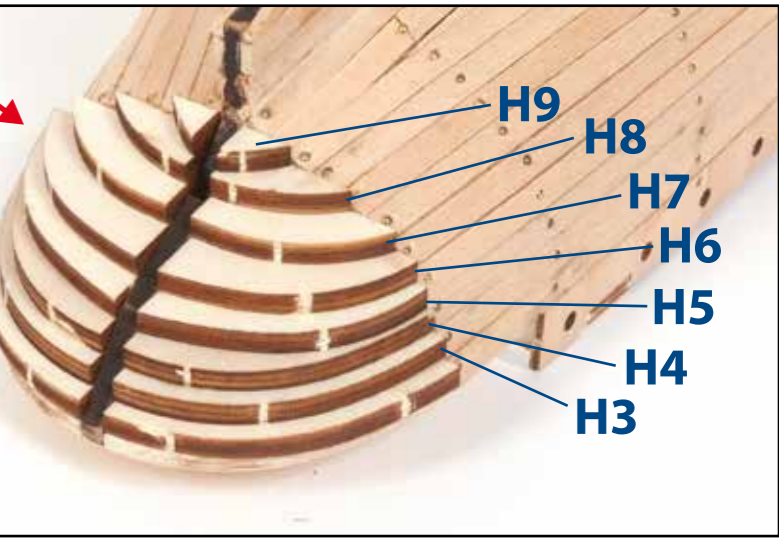
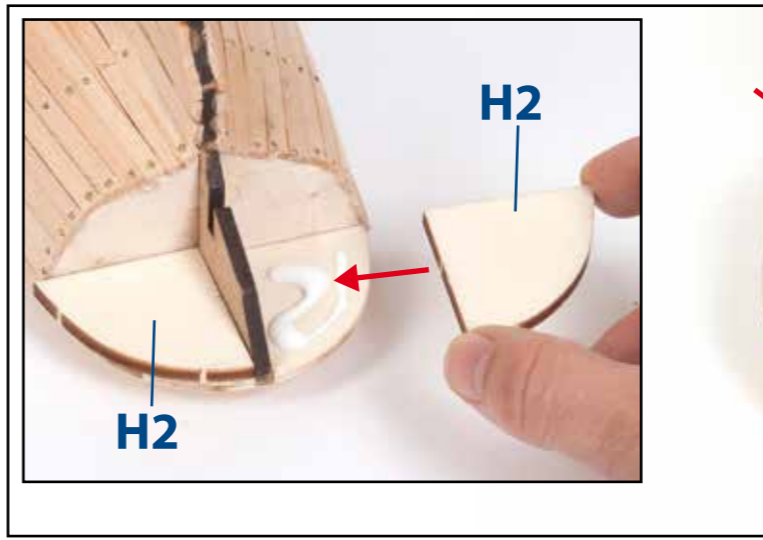
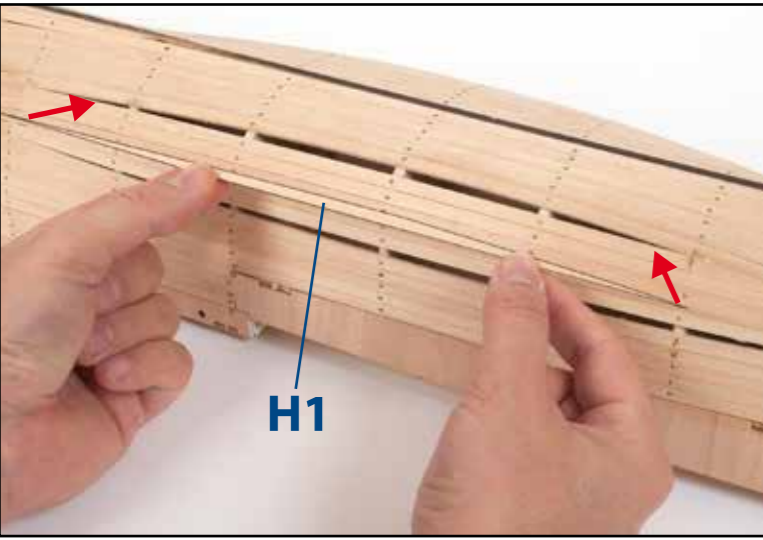
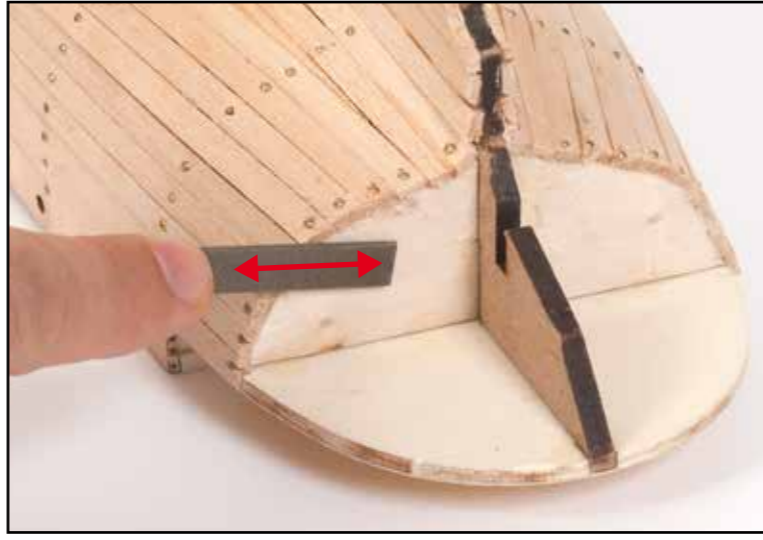
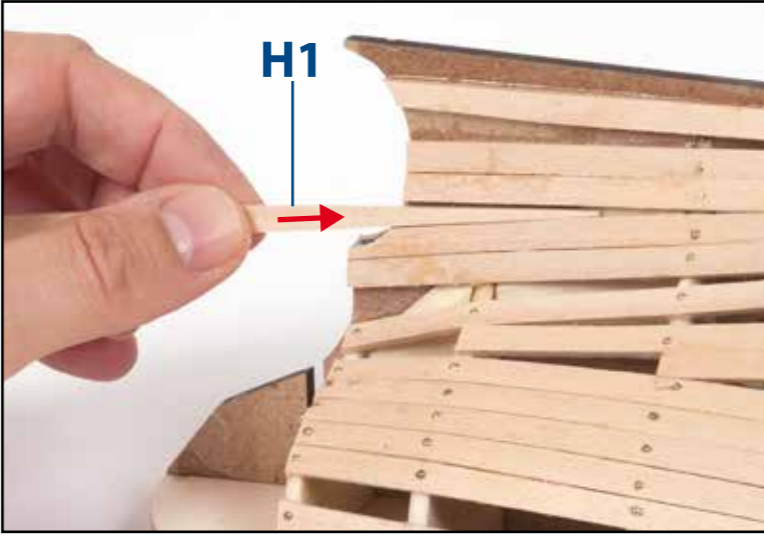
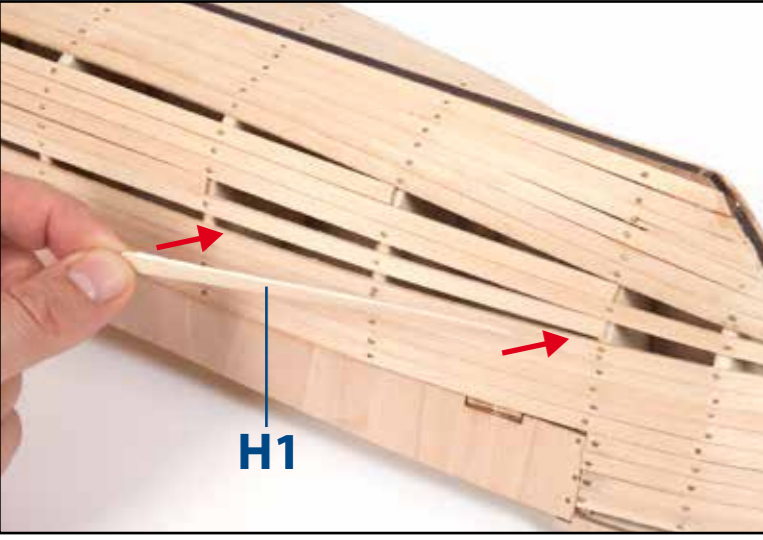
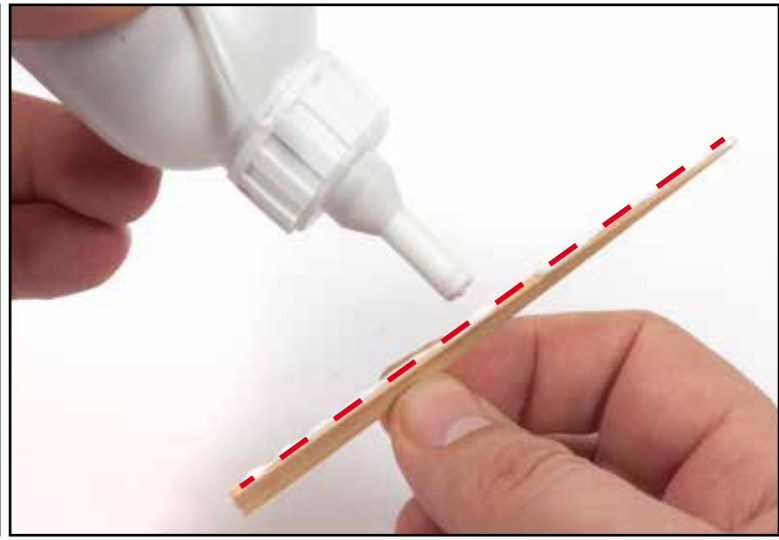
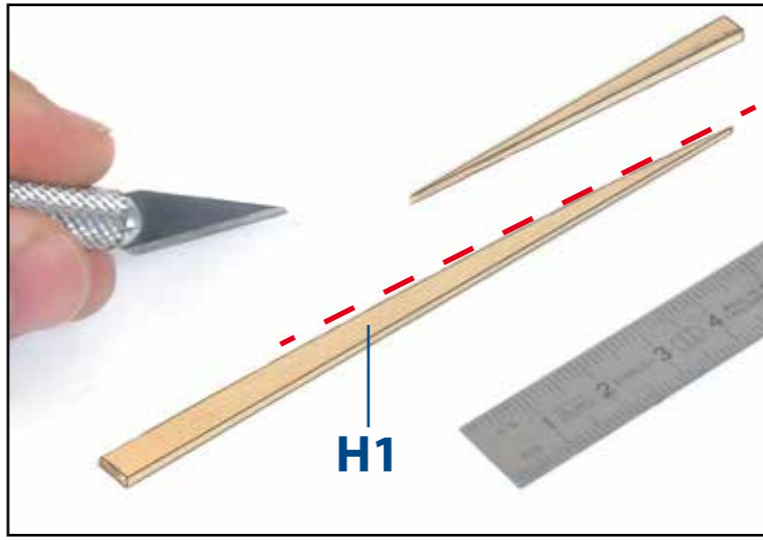
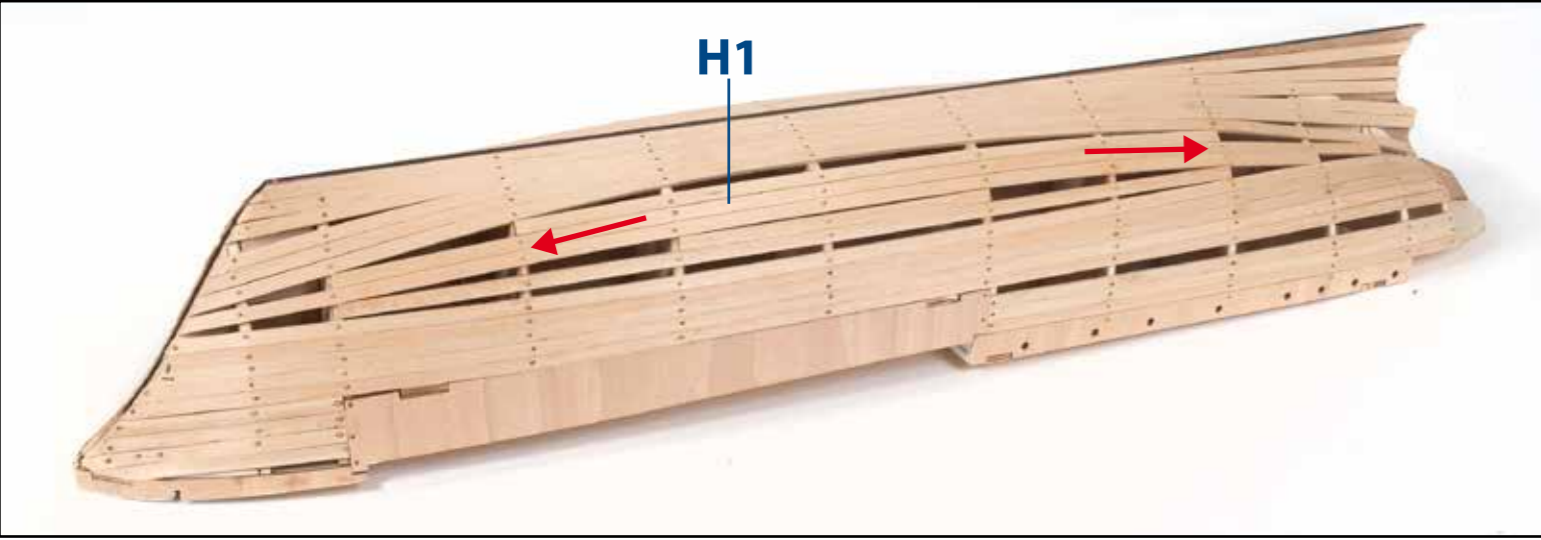
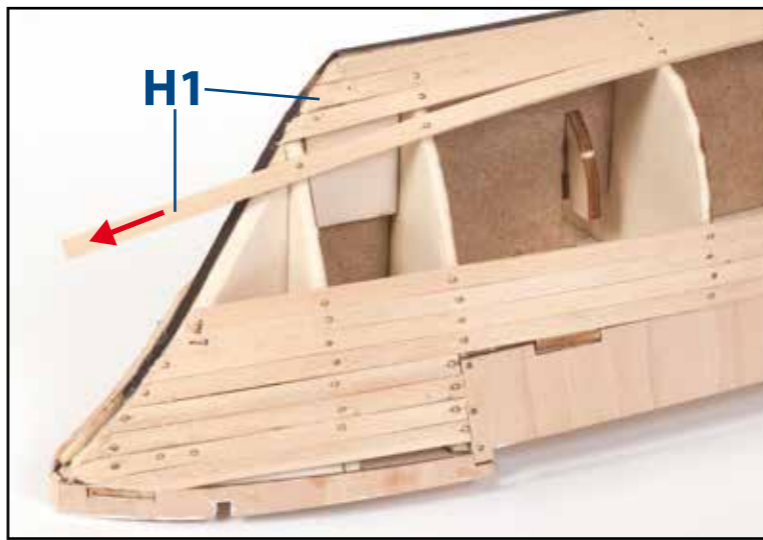
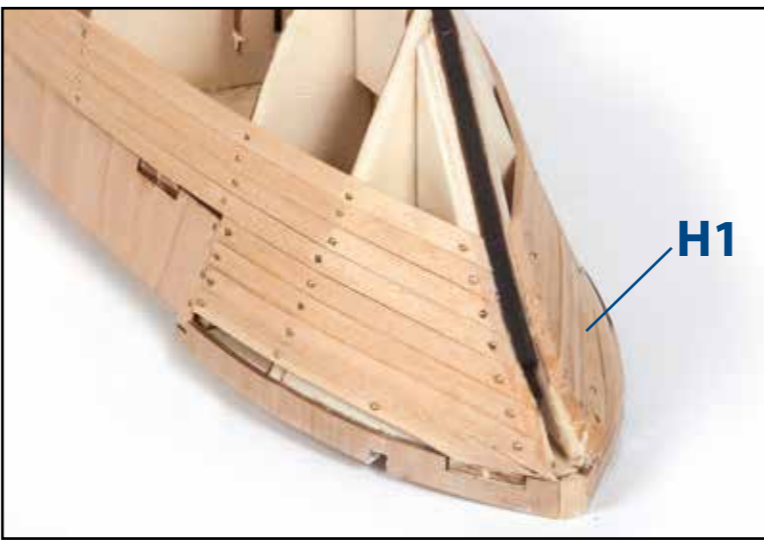
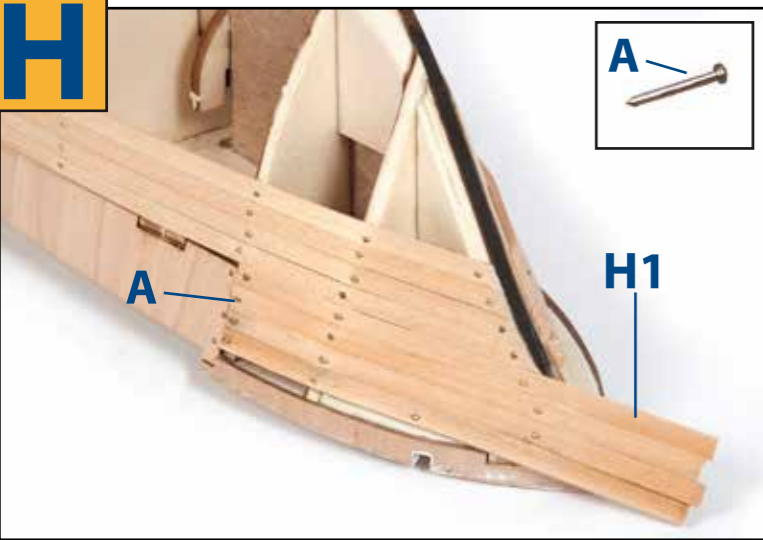

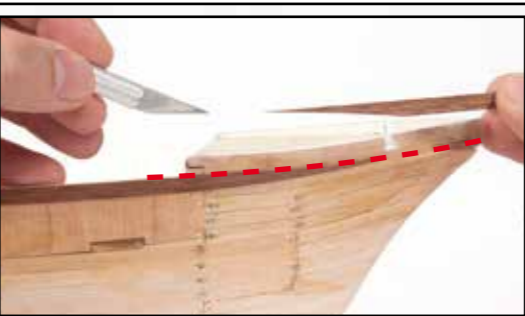
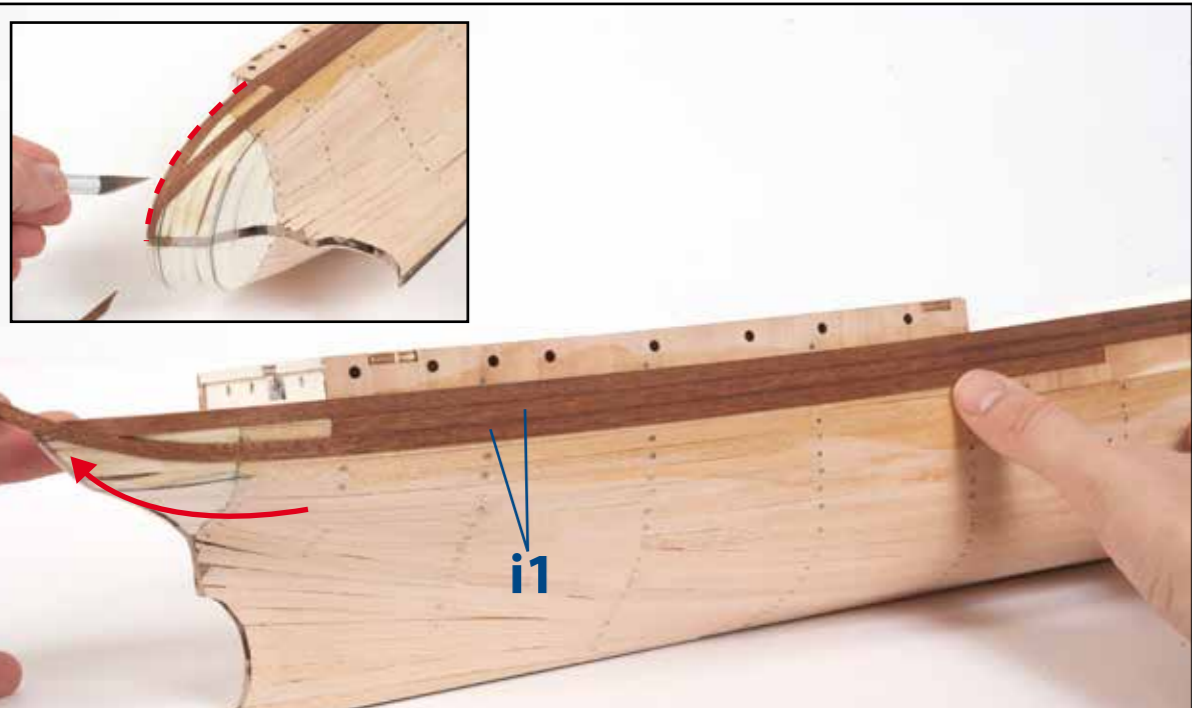
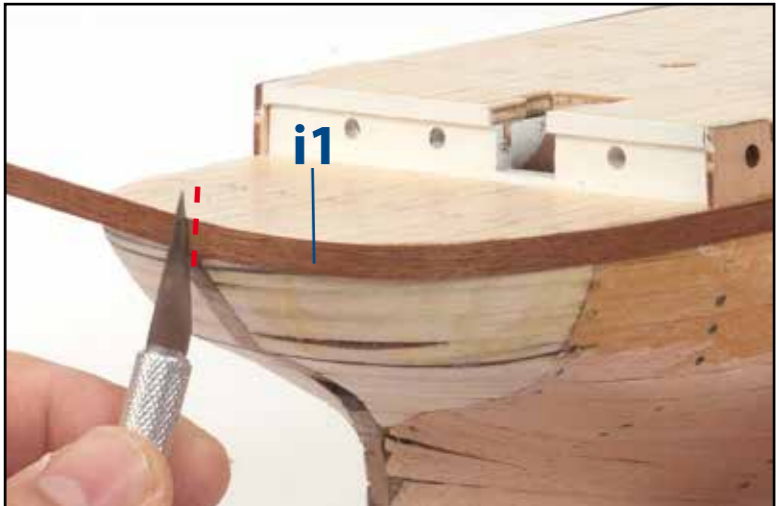
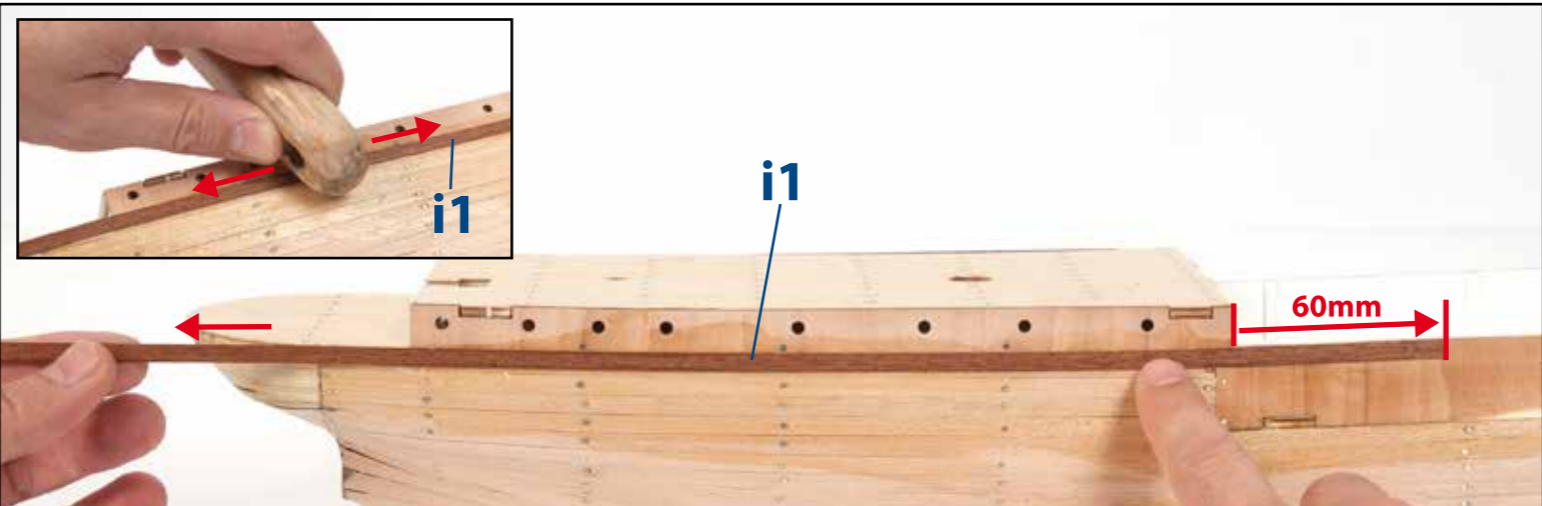
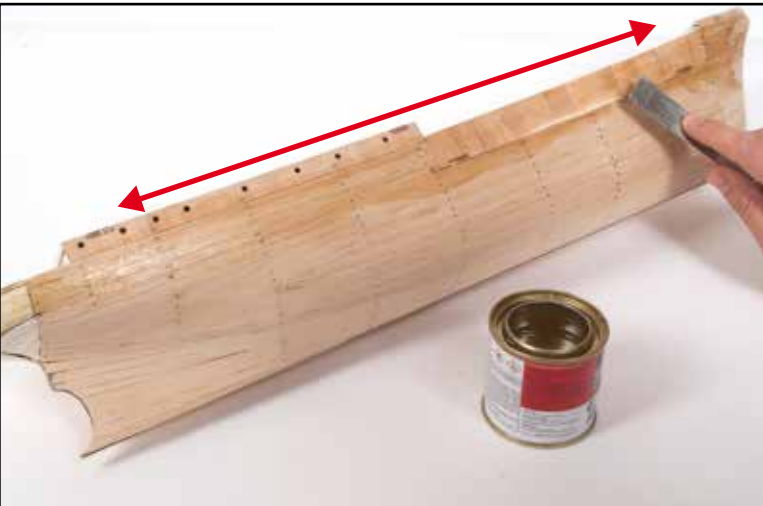
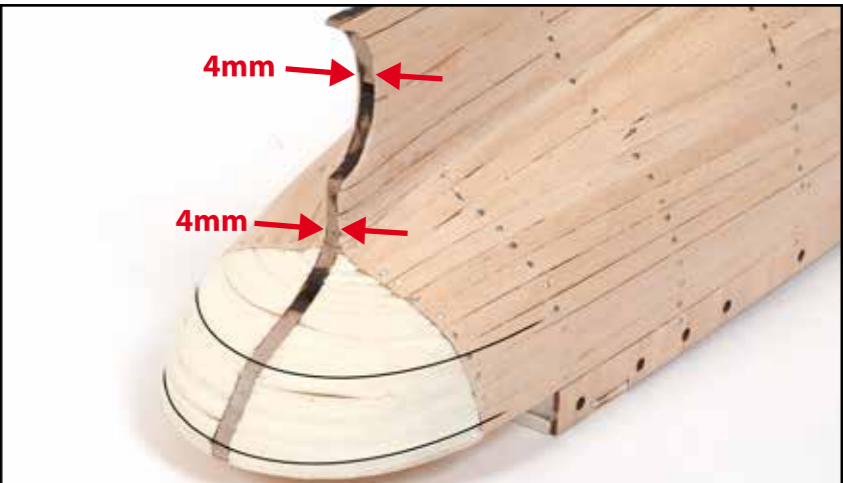
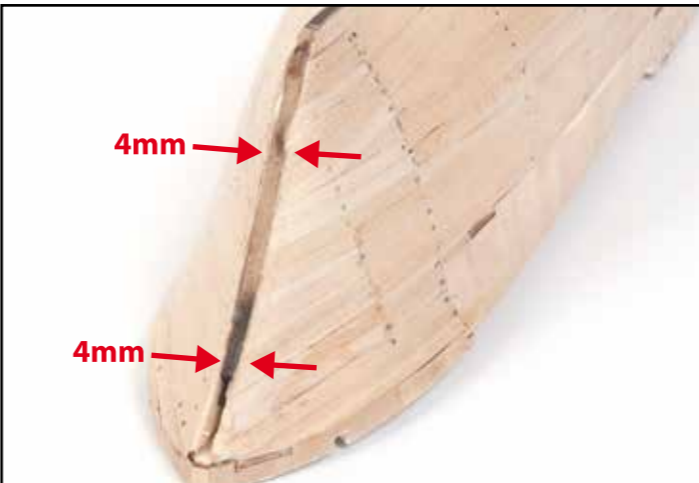
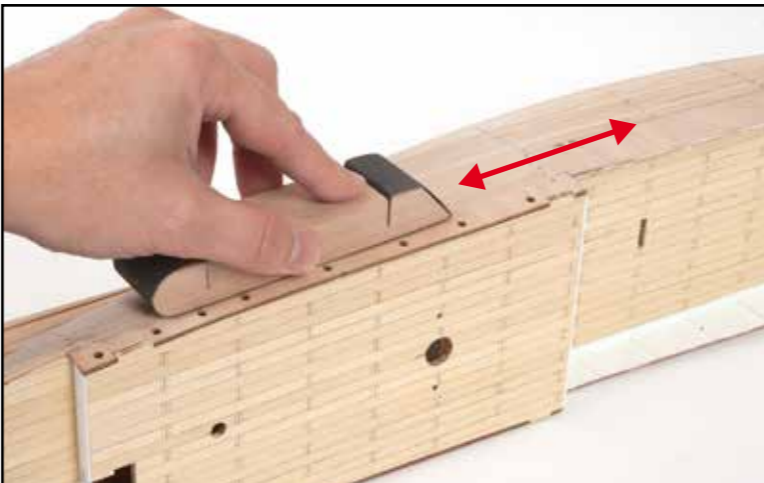
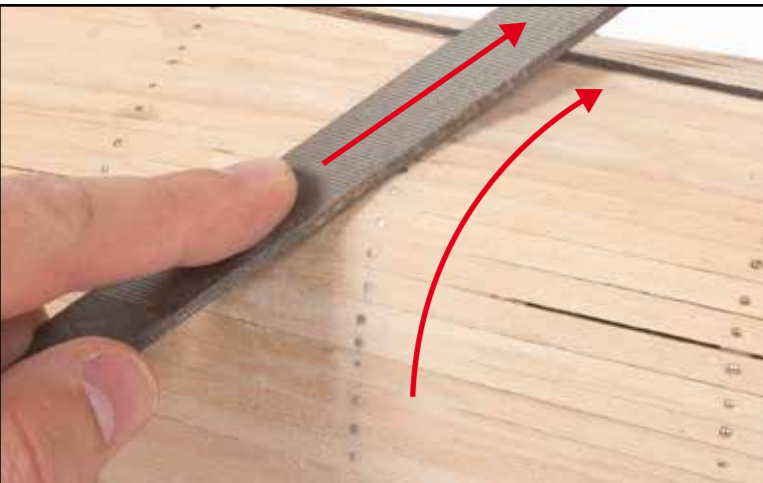
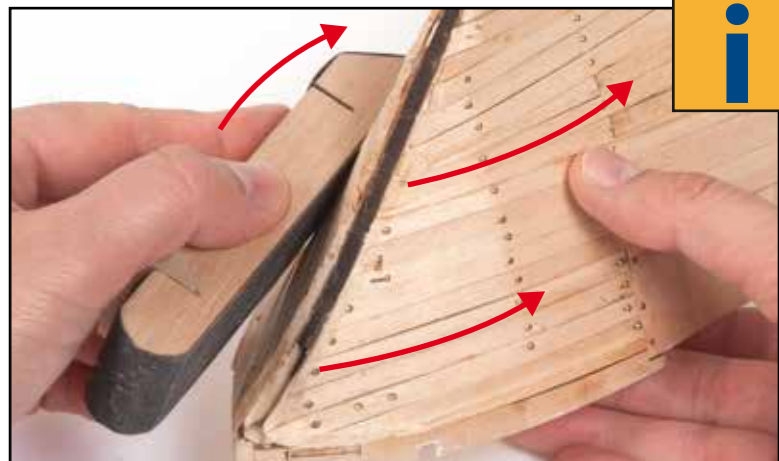
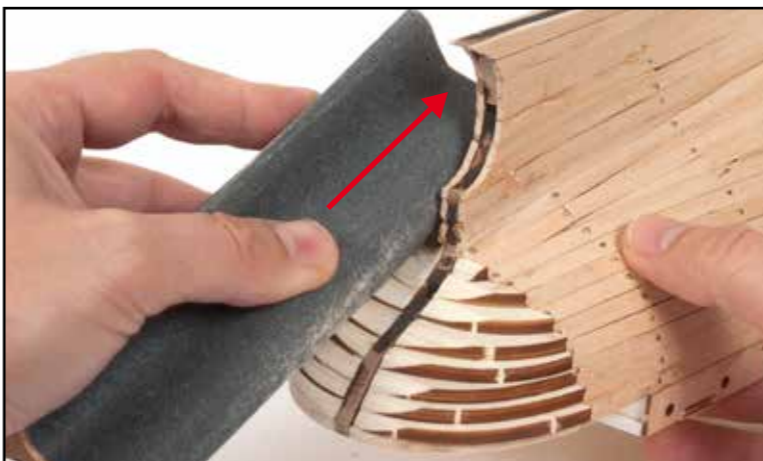
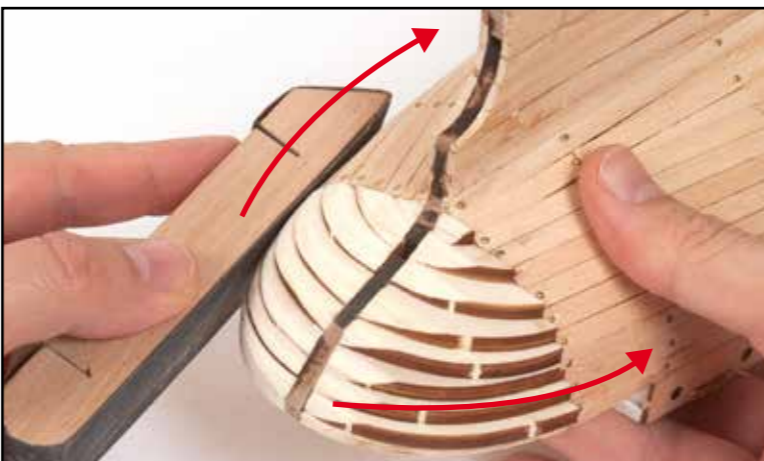
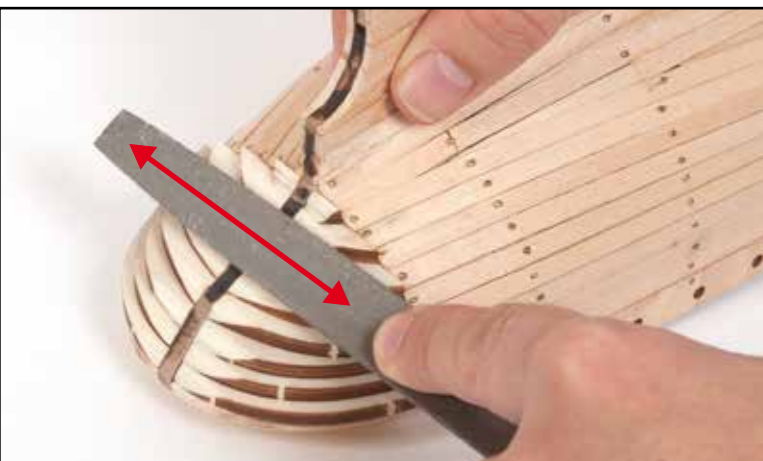

J

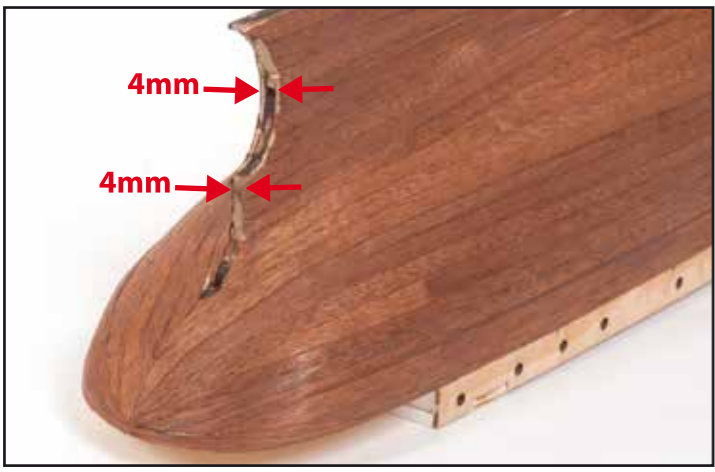
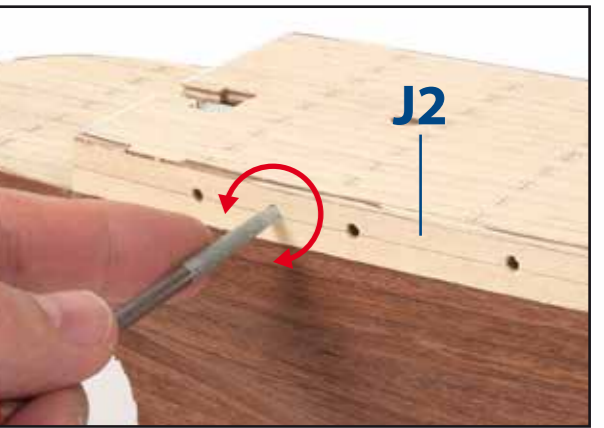
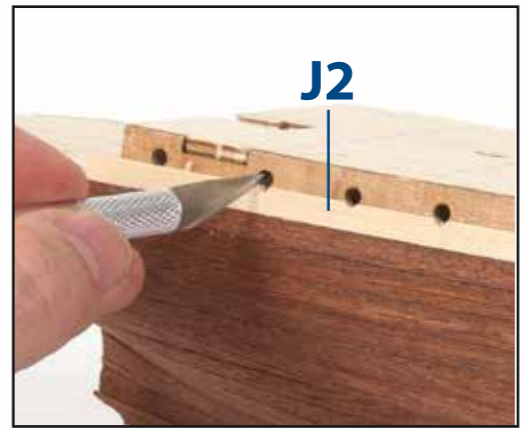
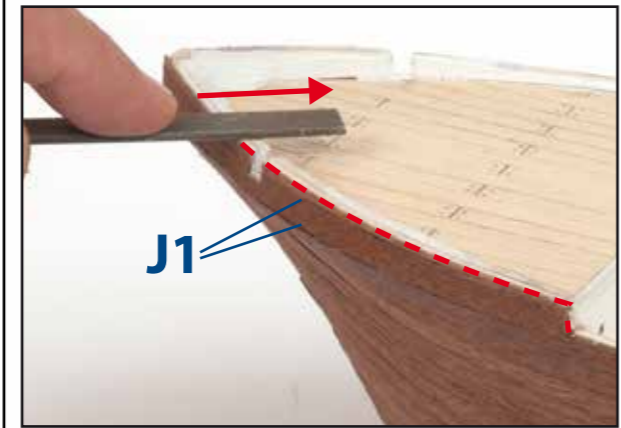
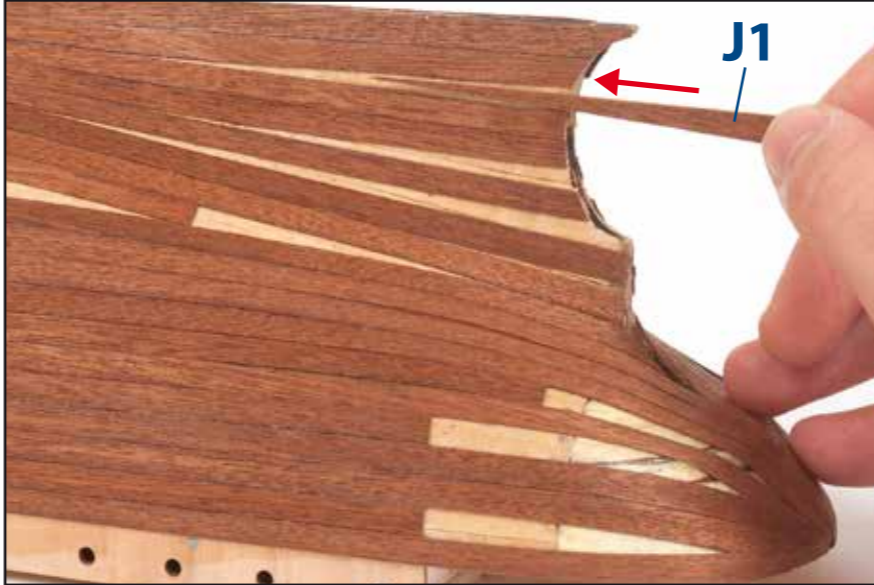
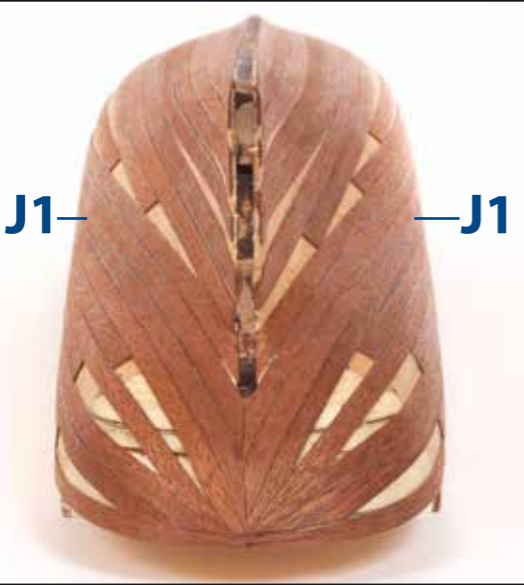
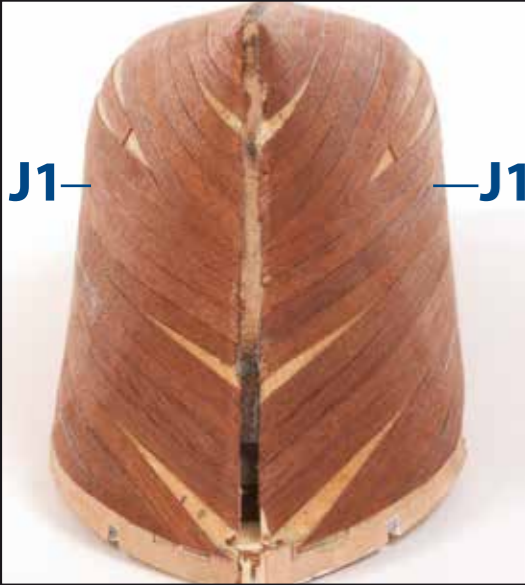
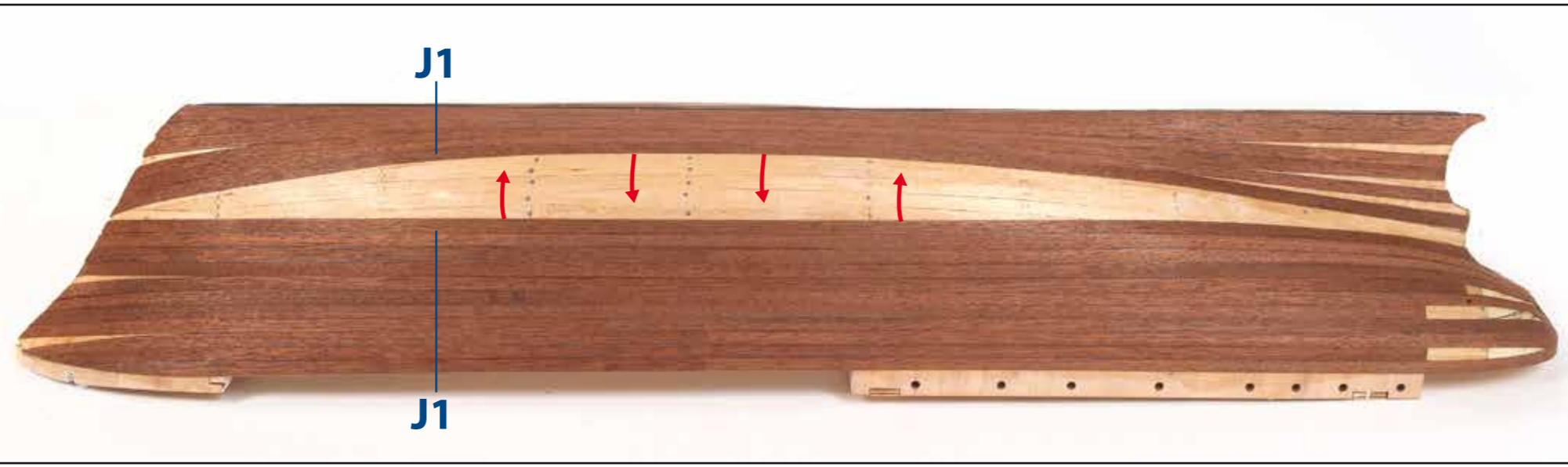

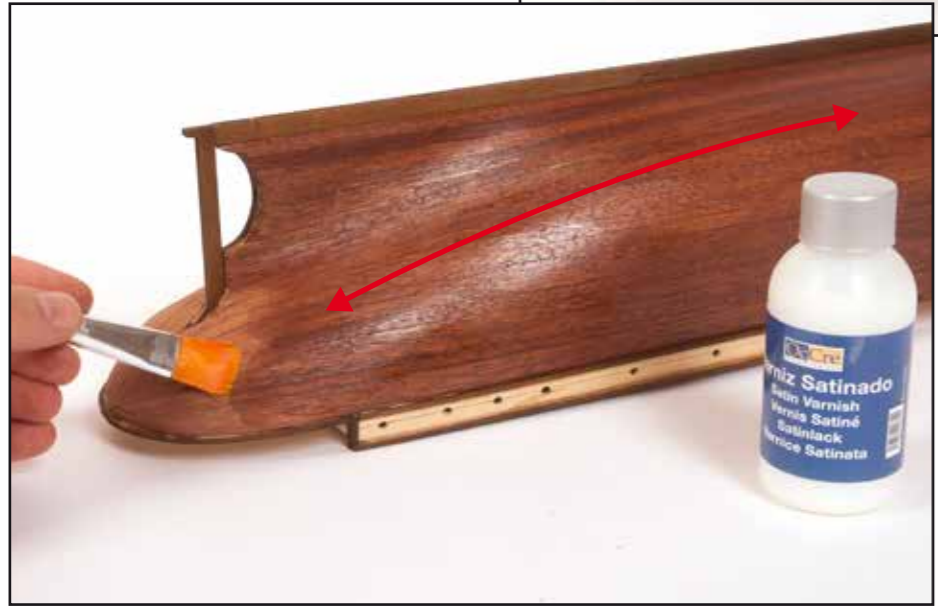
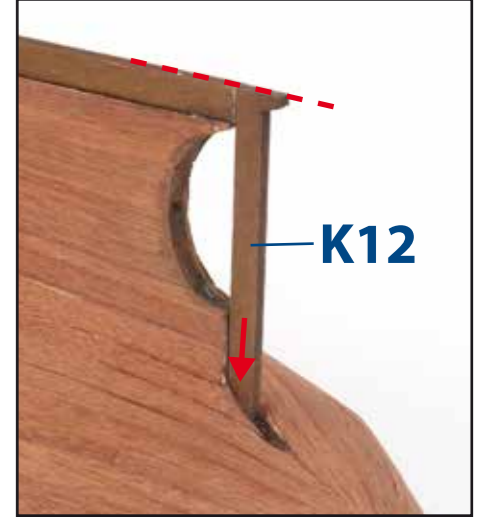
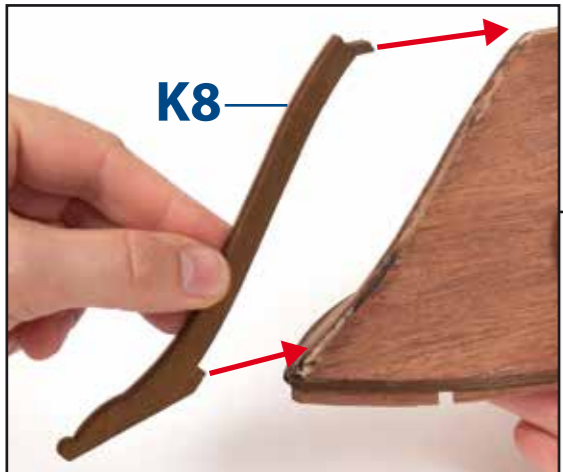
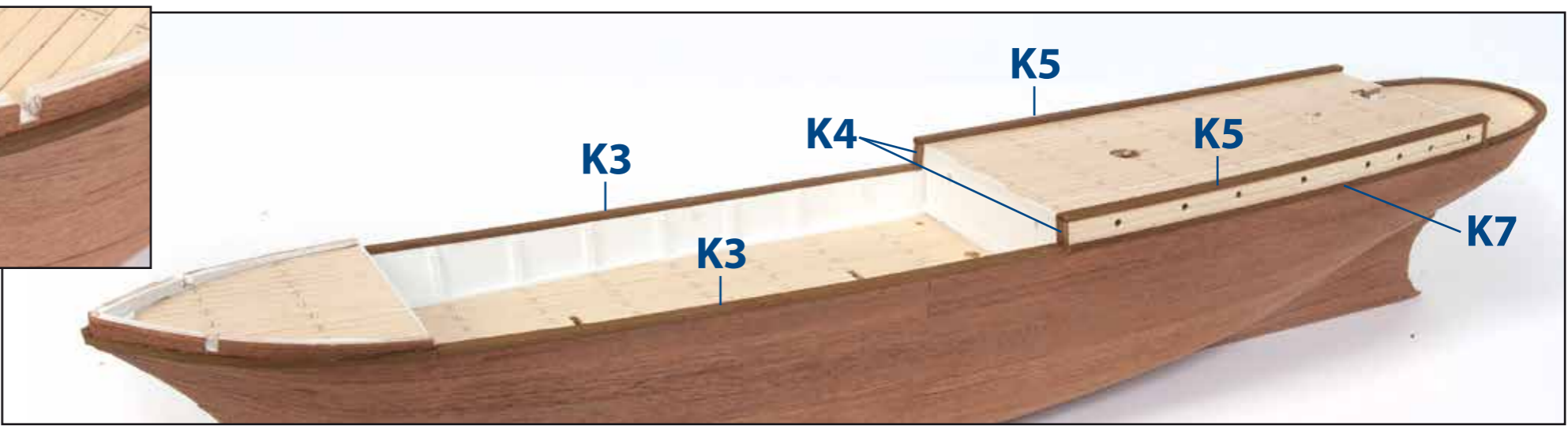
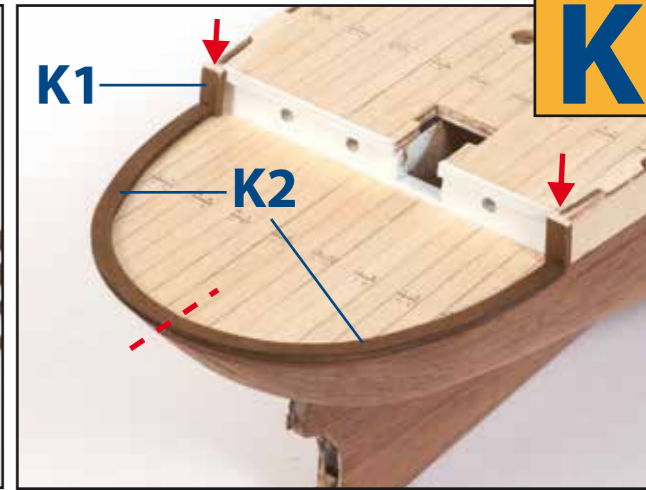
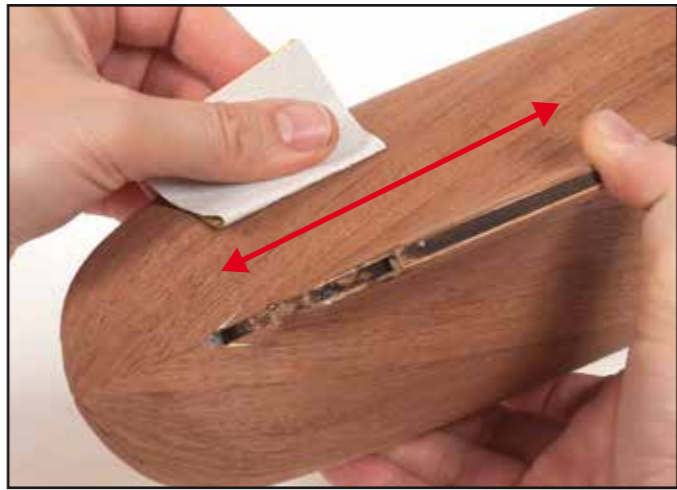
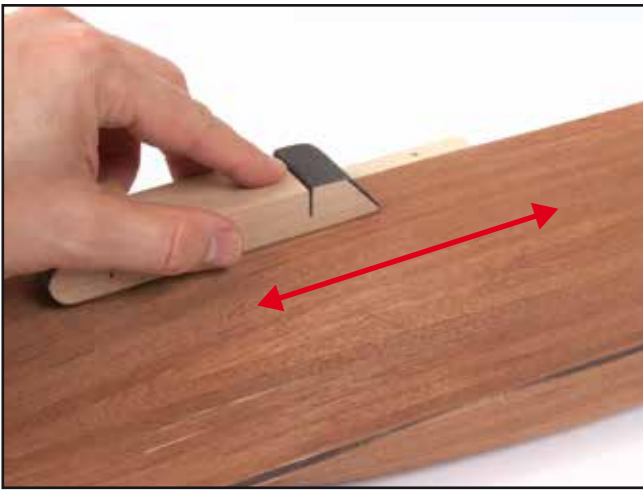

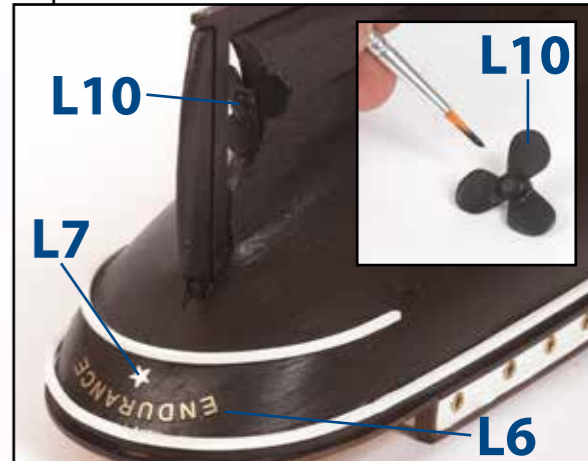
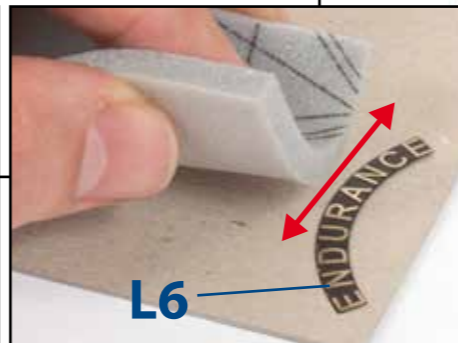
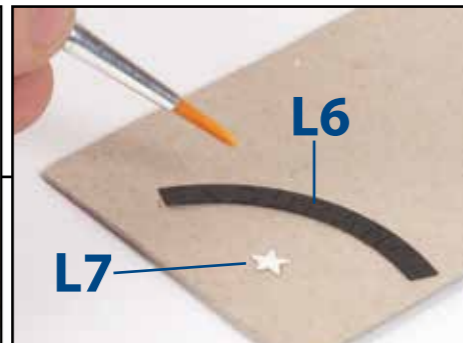
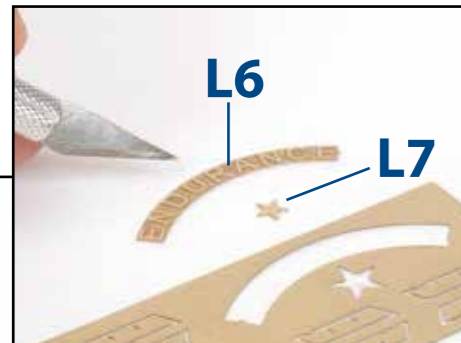
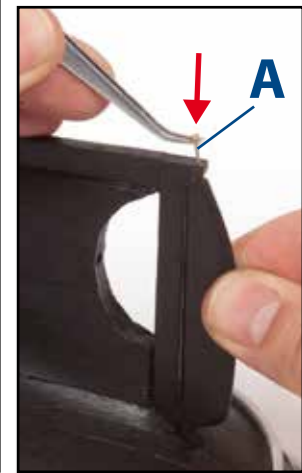
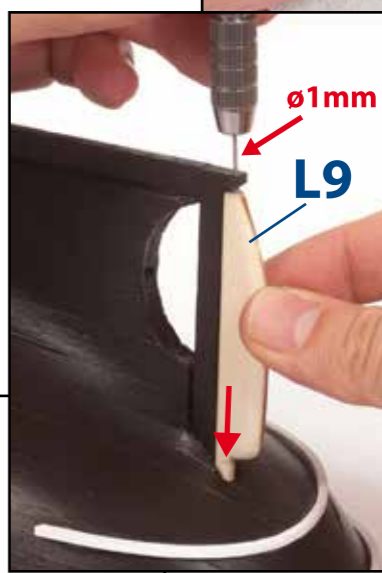
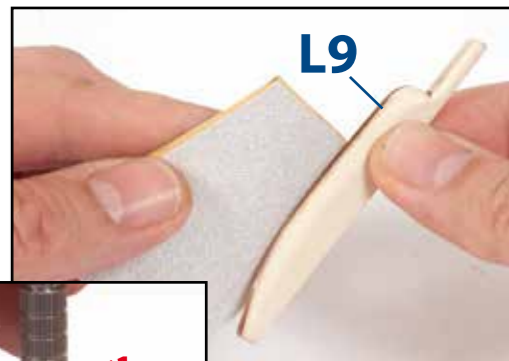
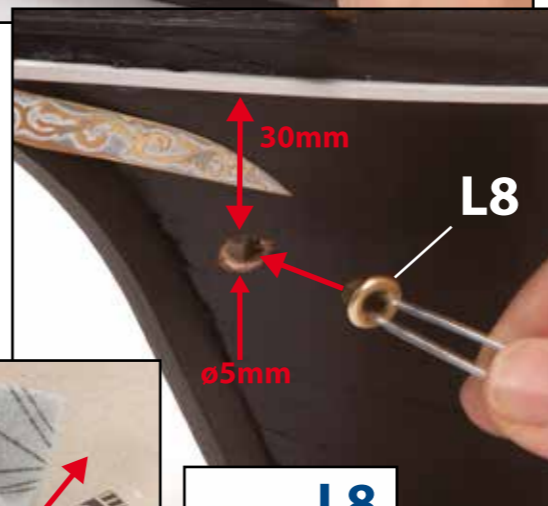
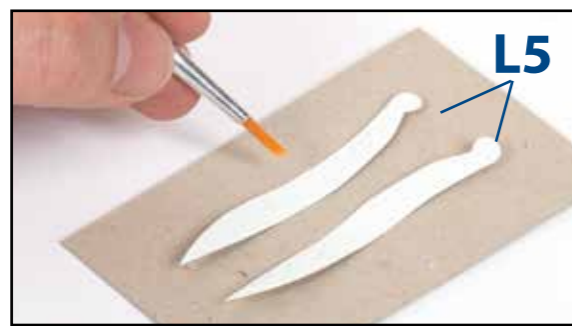
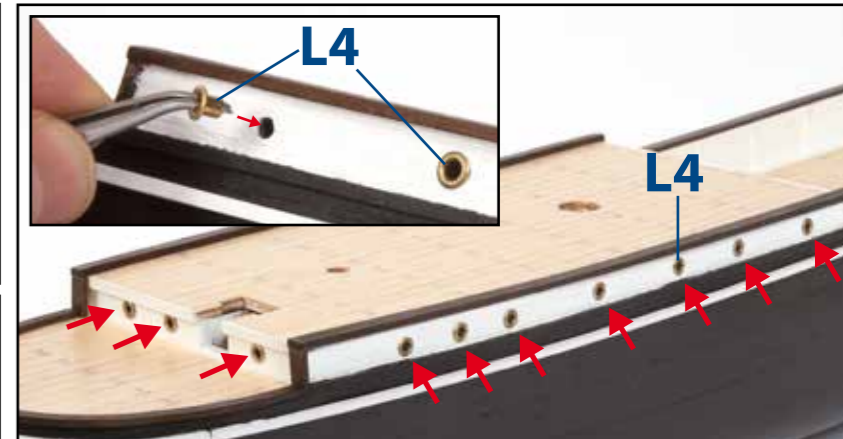
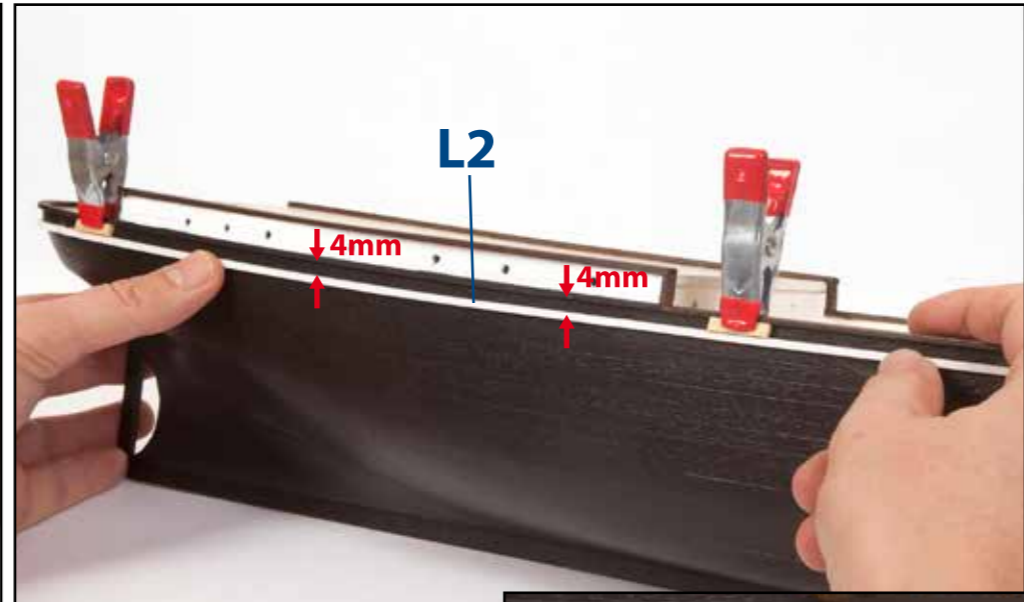
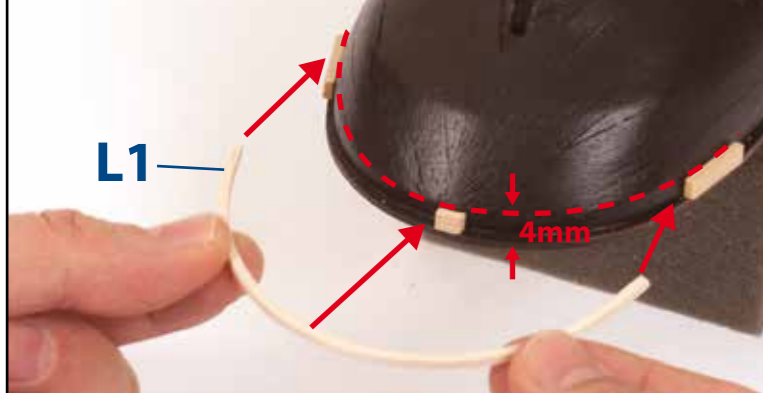
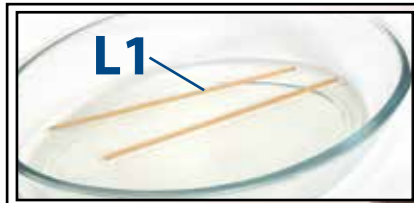
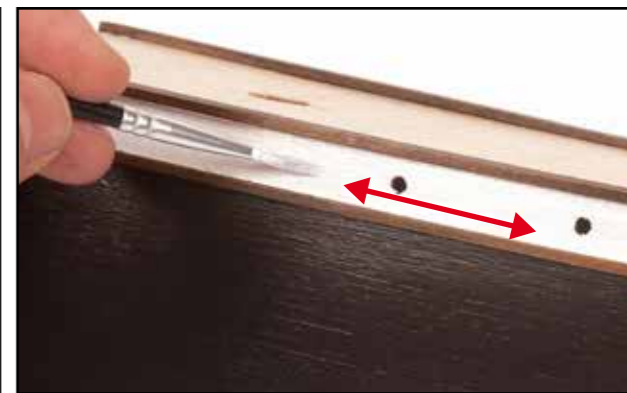
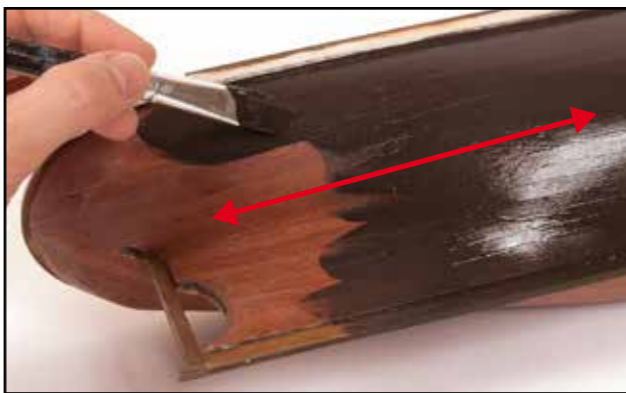
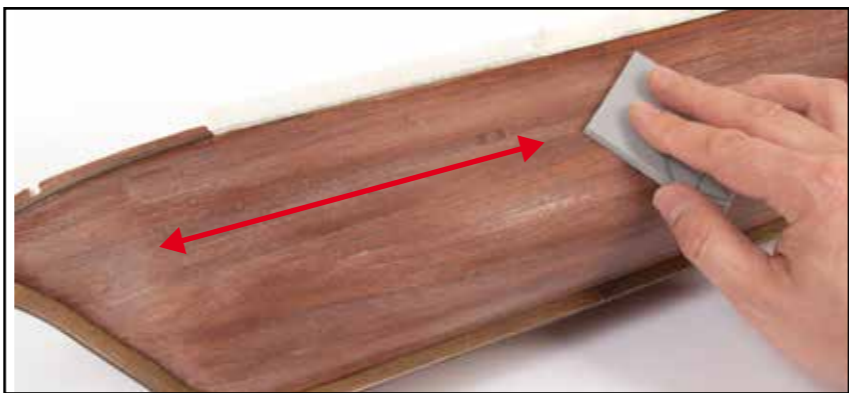

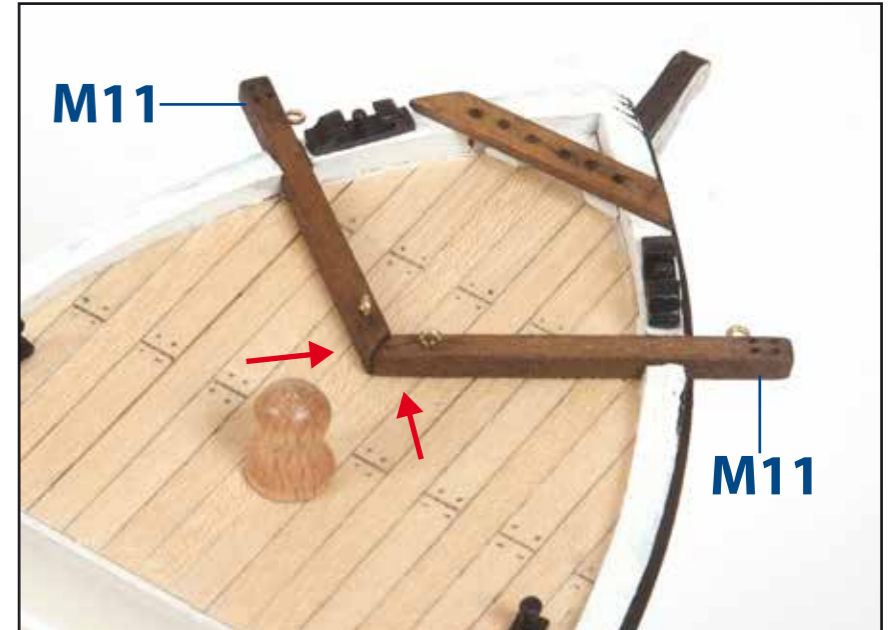
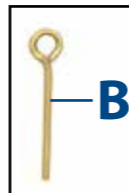
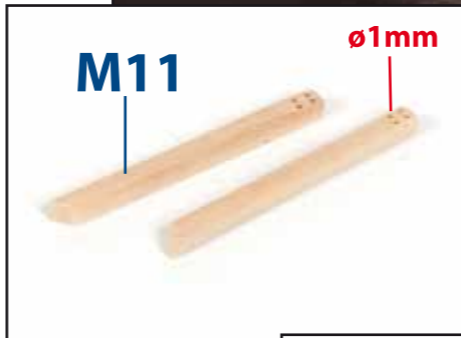
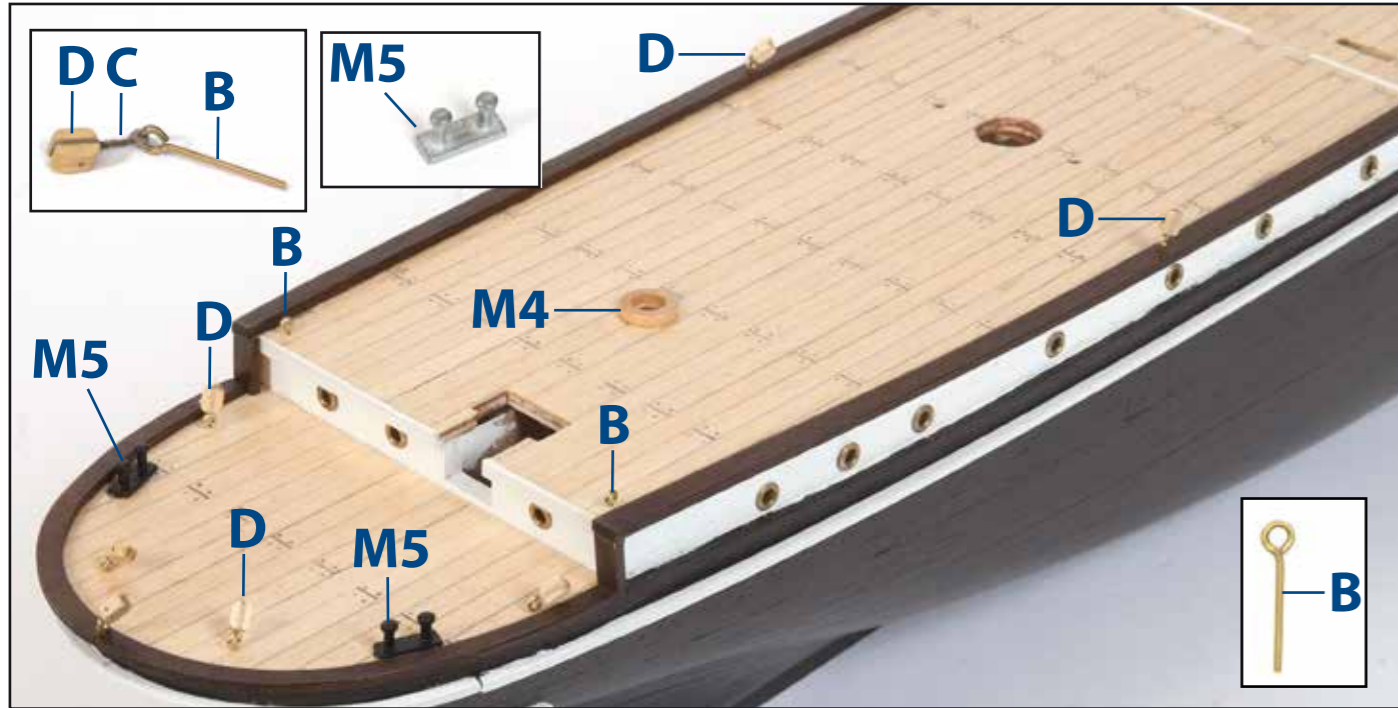
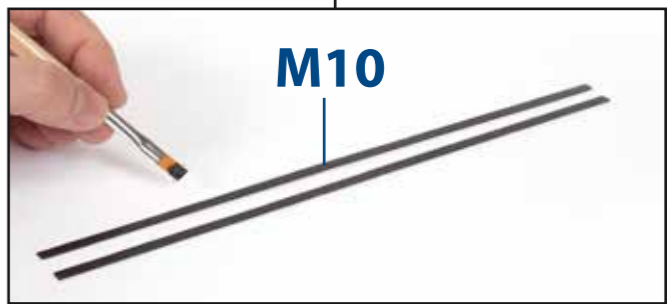
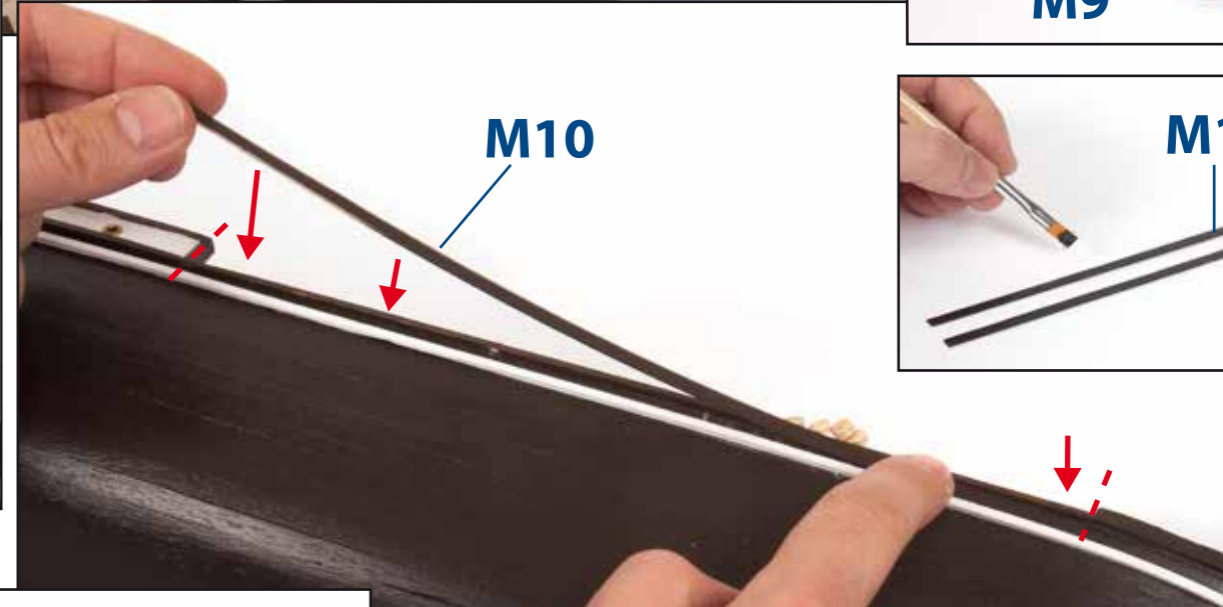
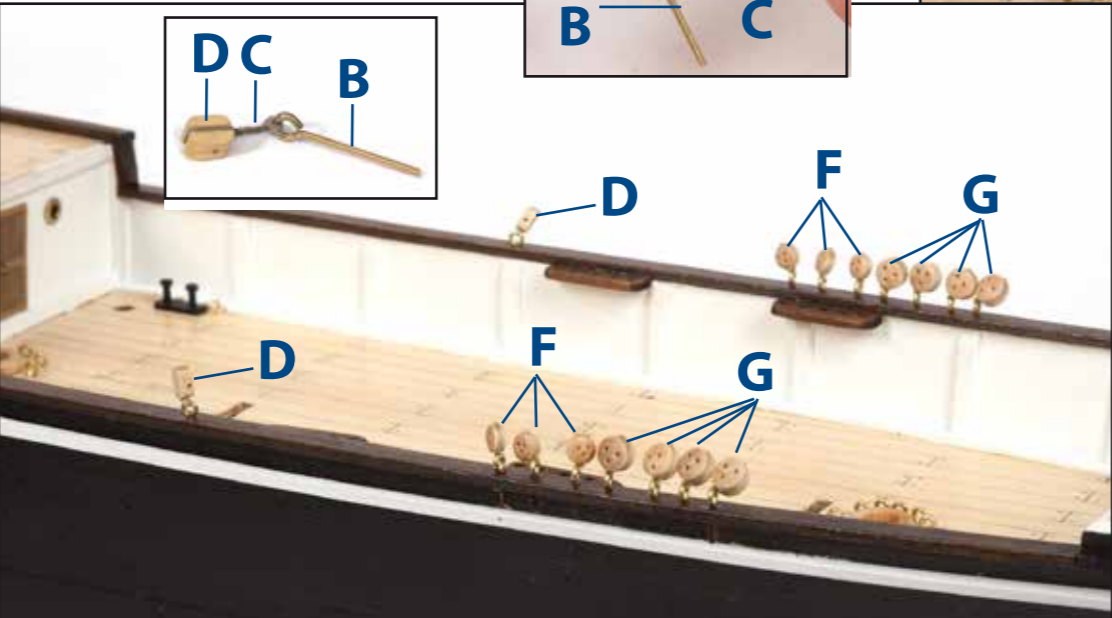
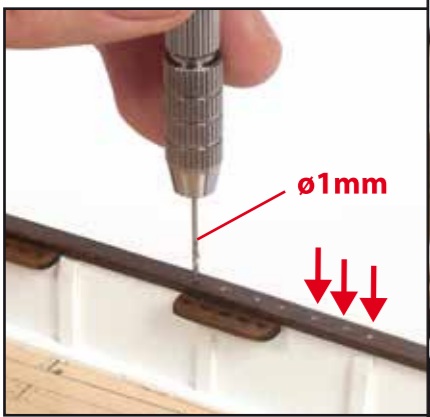
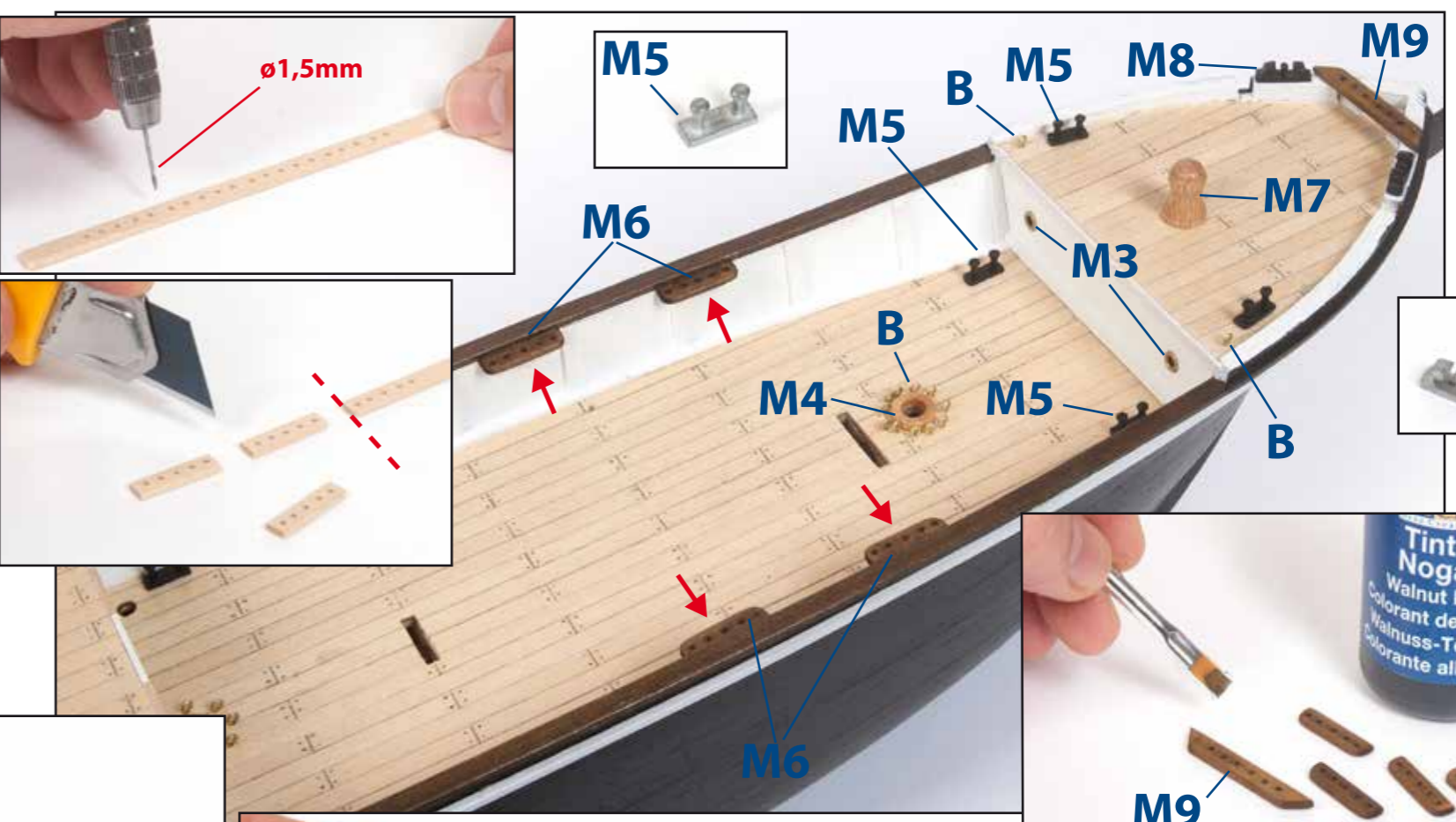
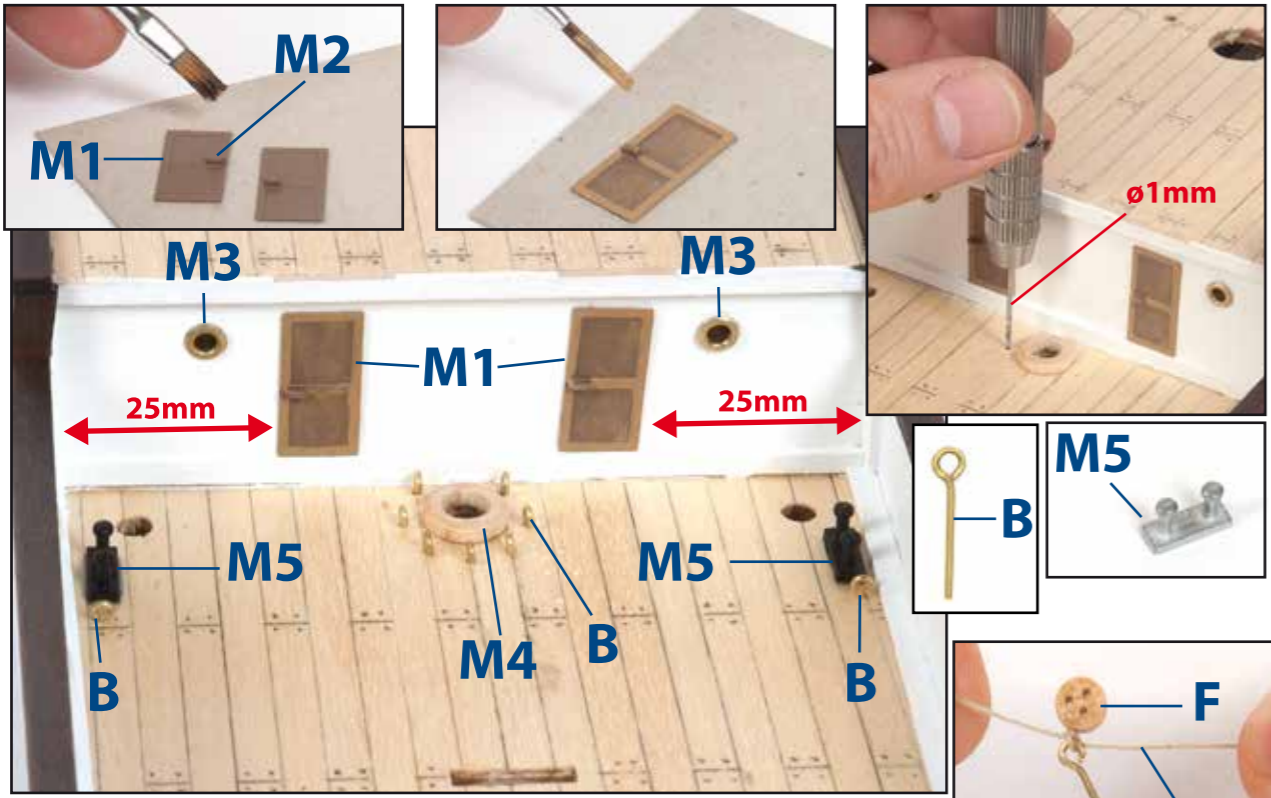

N

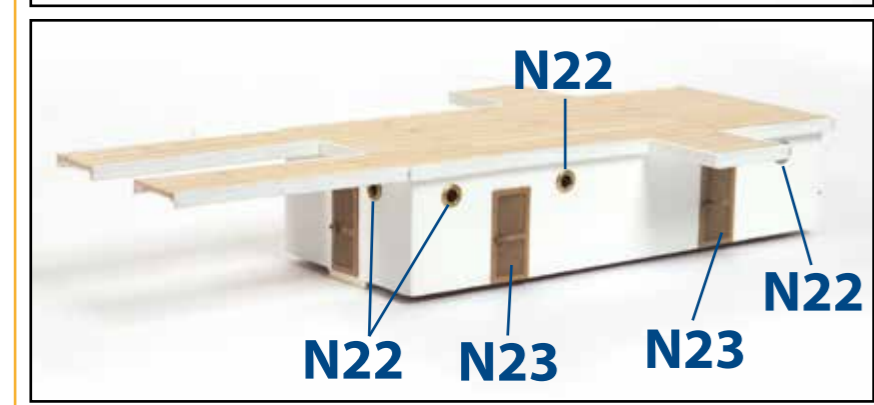
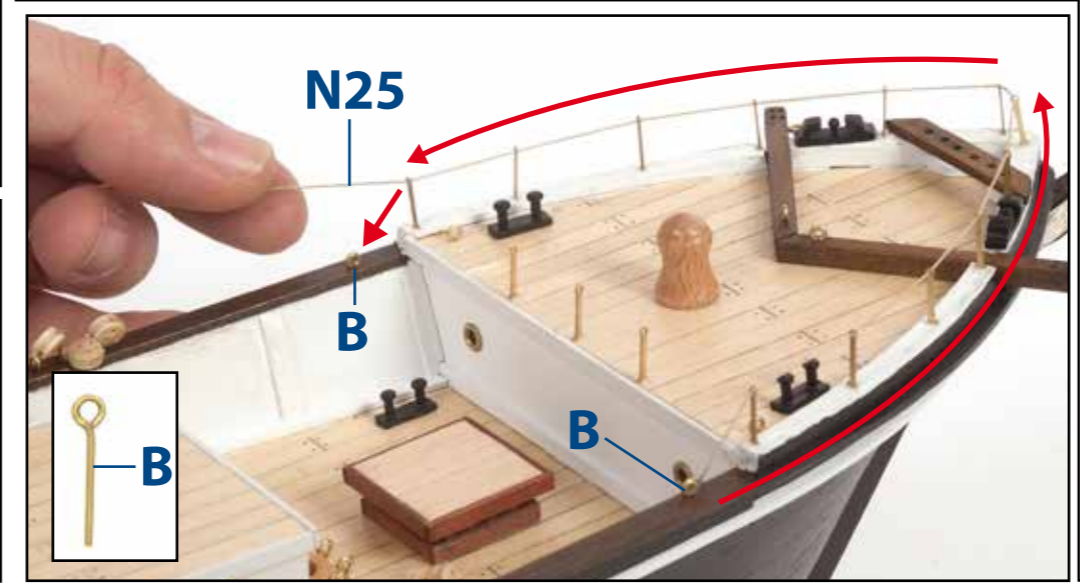
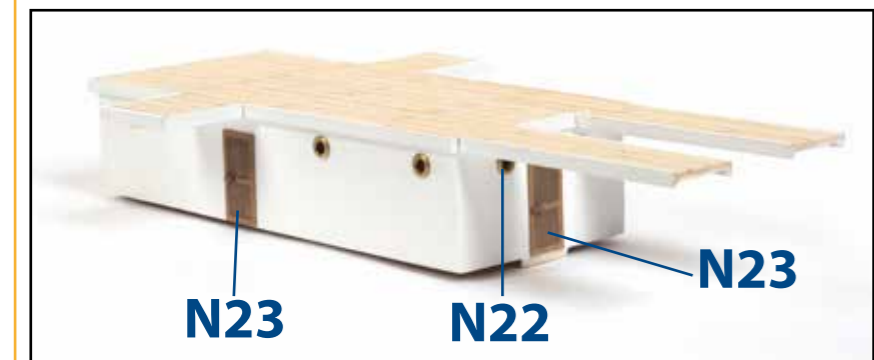
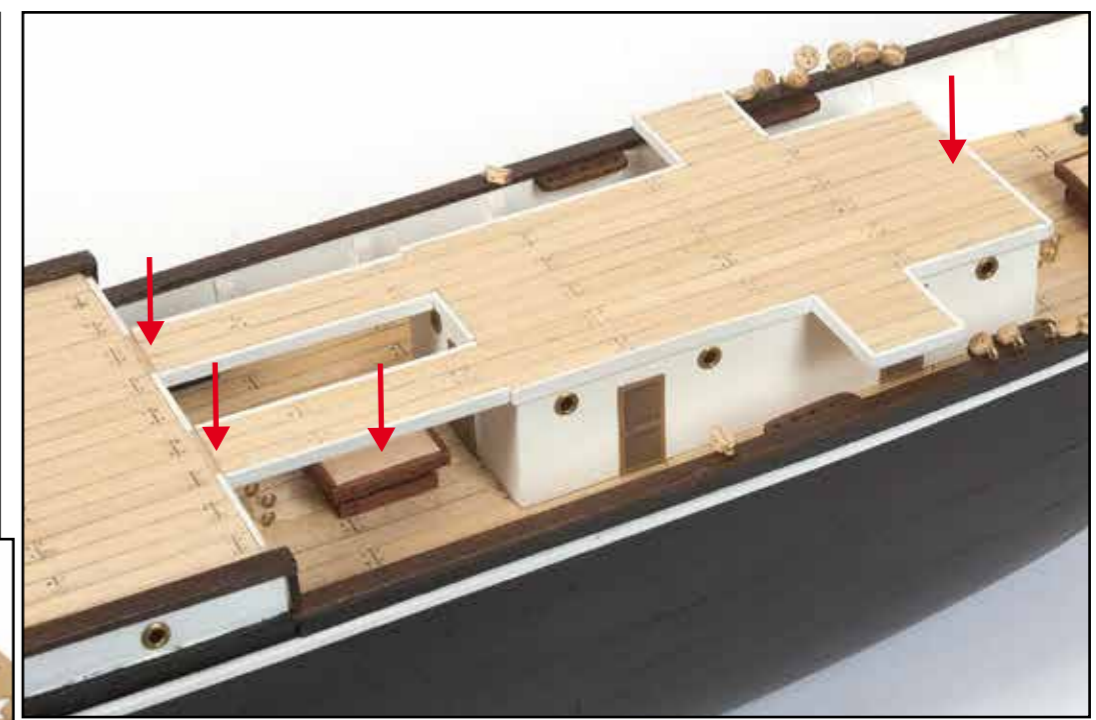
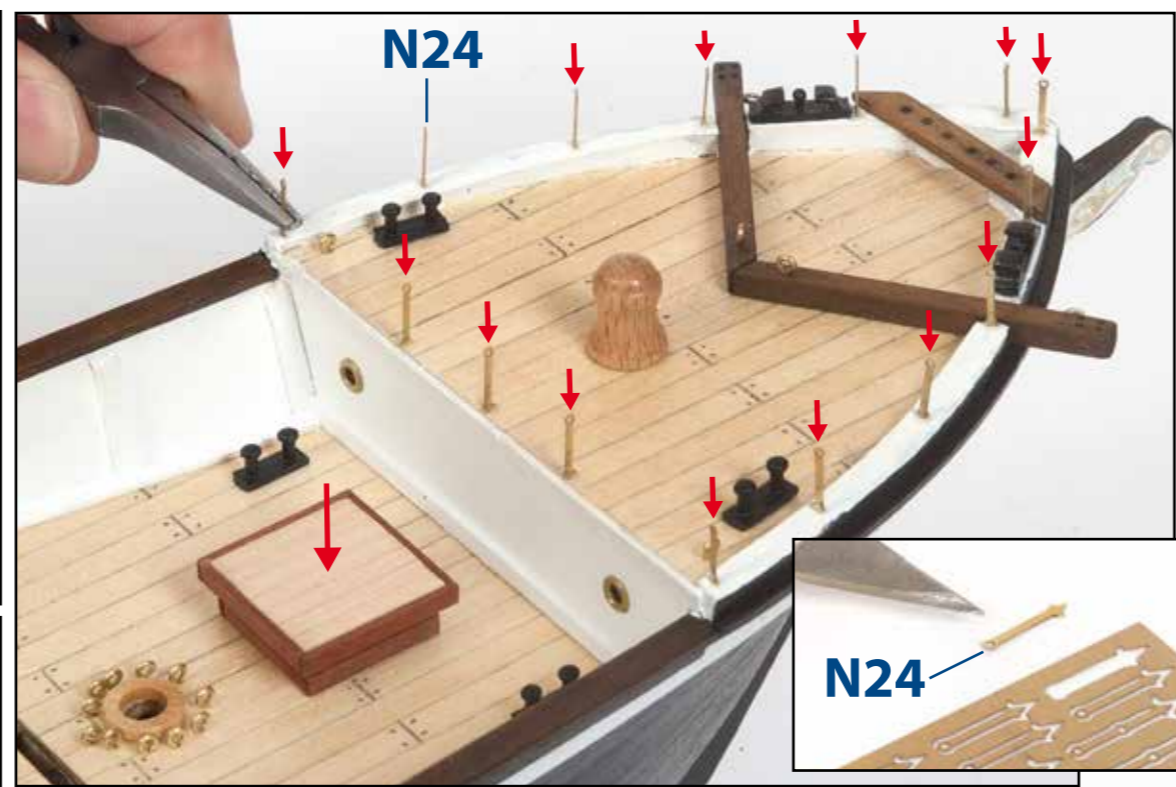
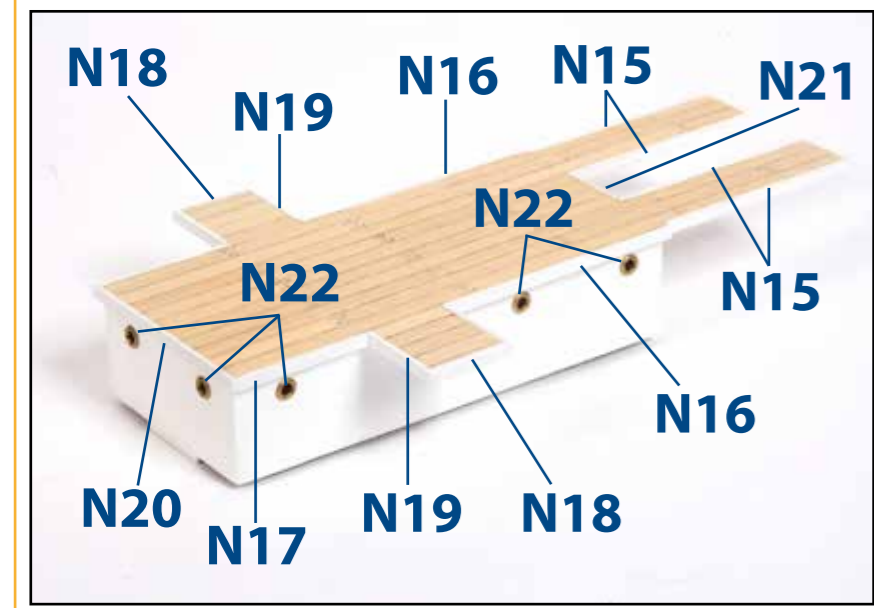
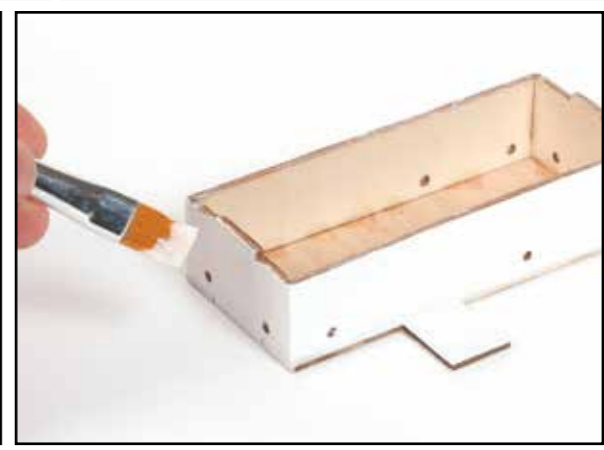
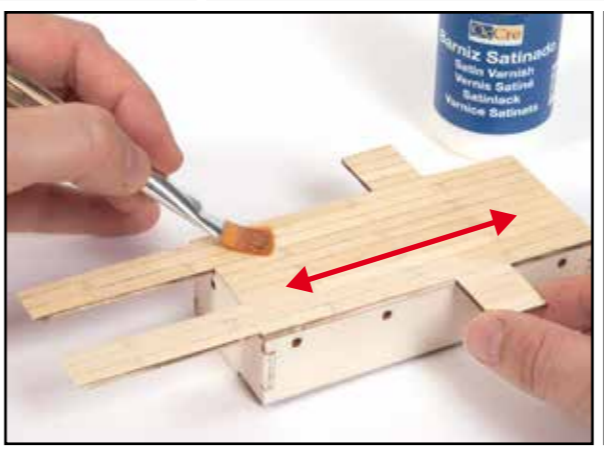
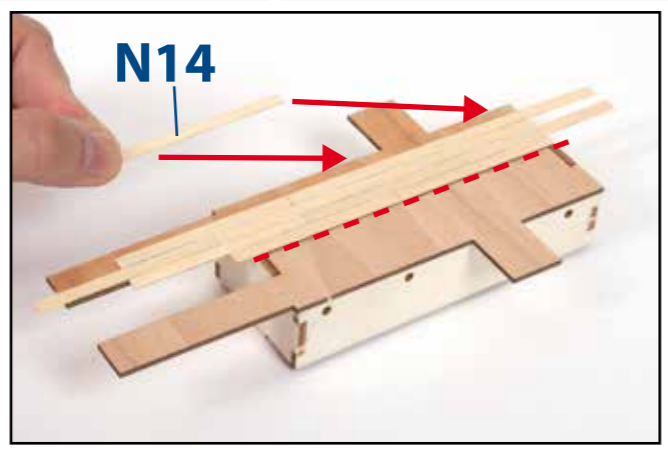
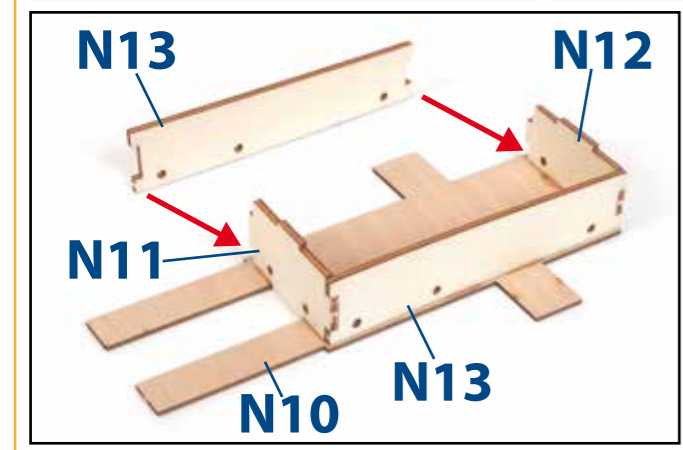
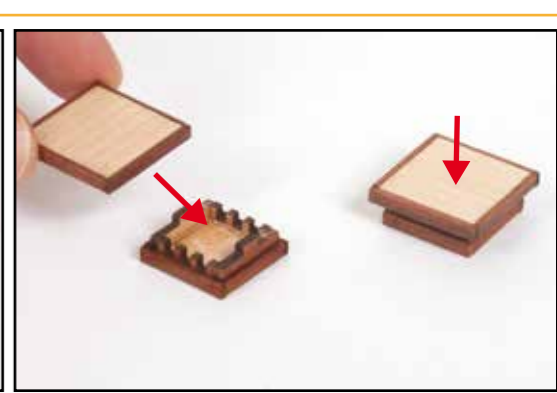
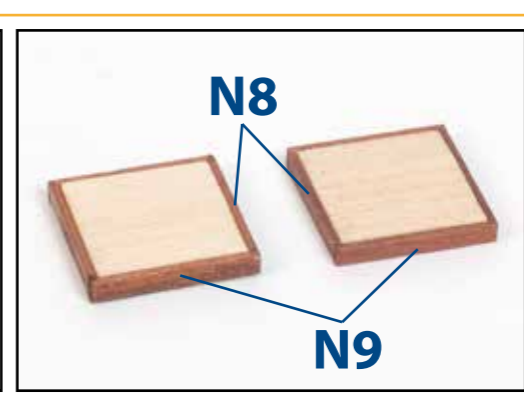
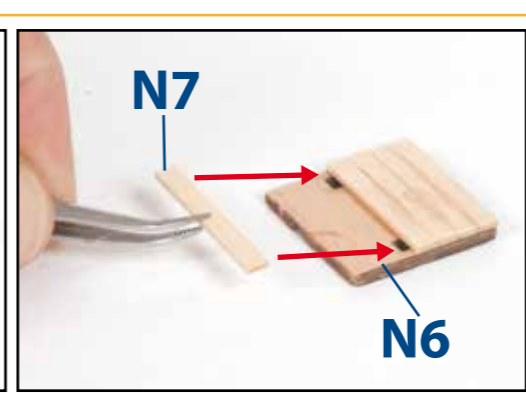
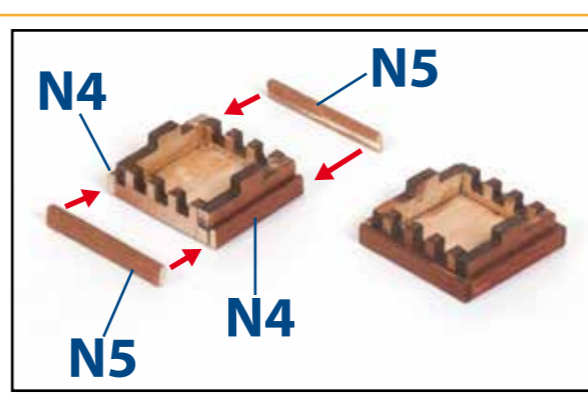
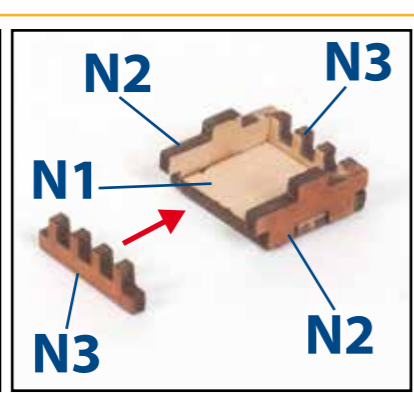

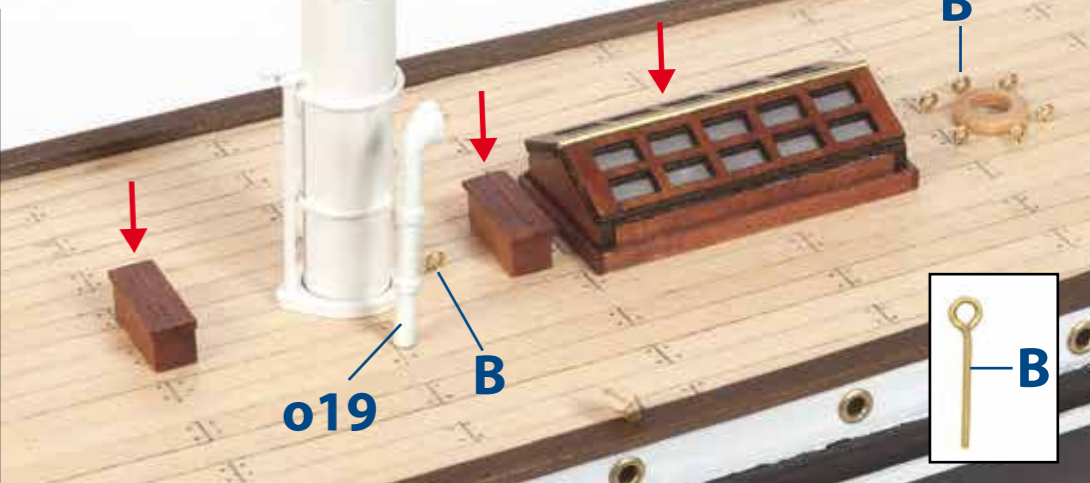
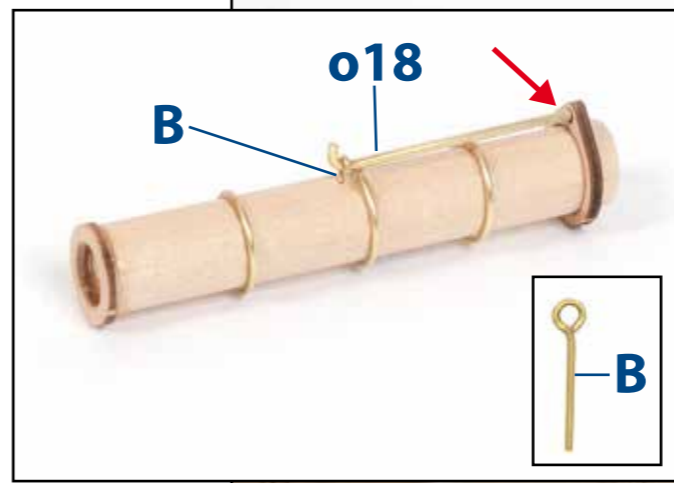
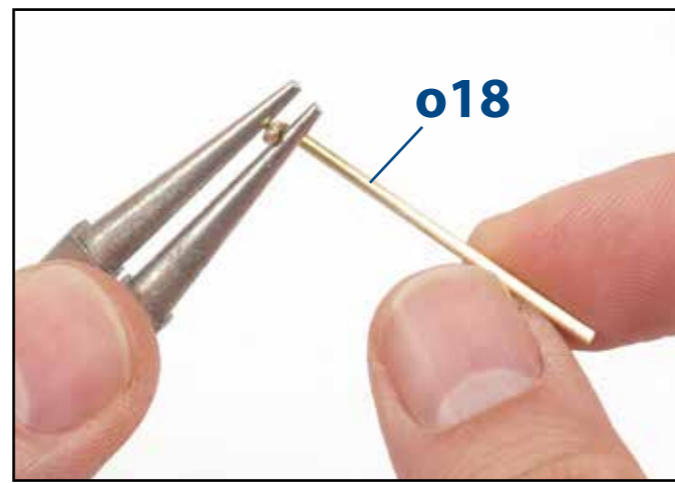
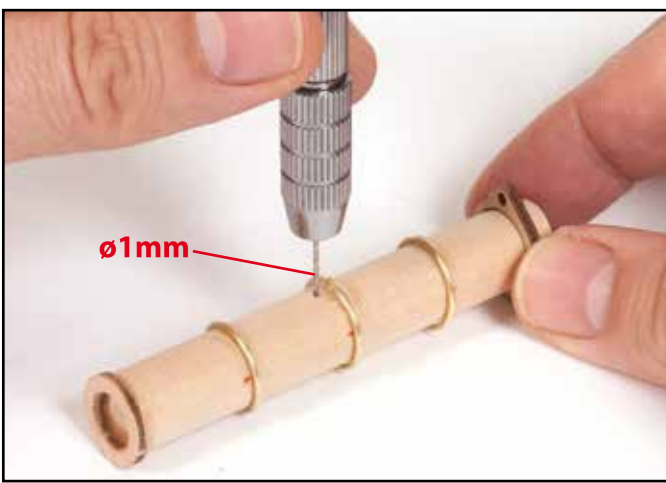
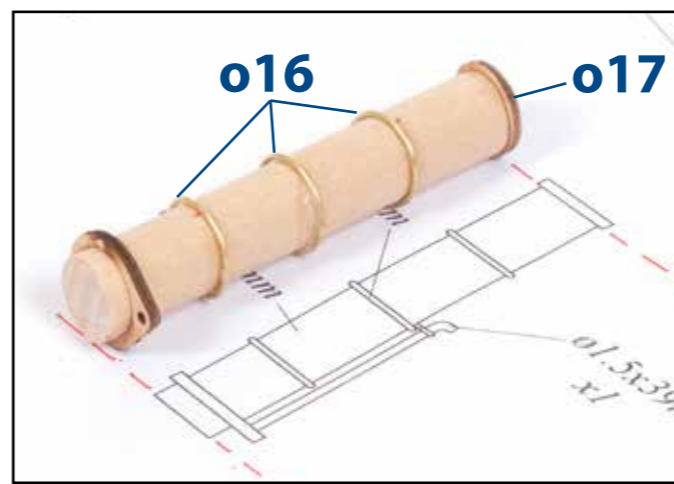
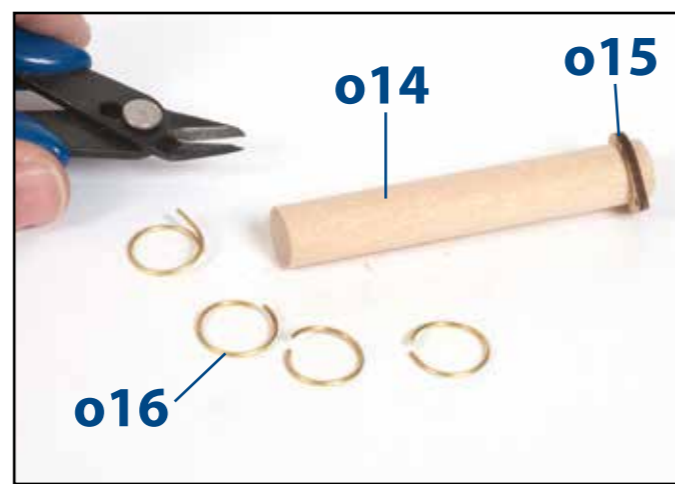
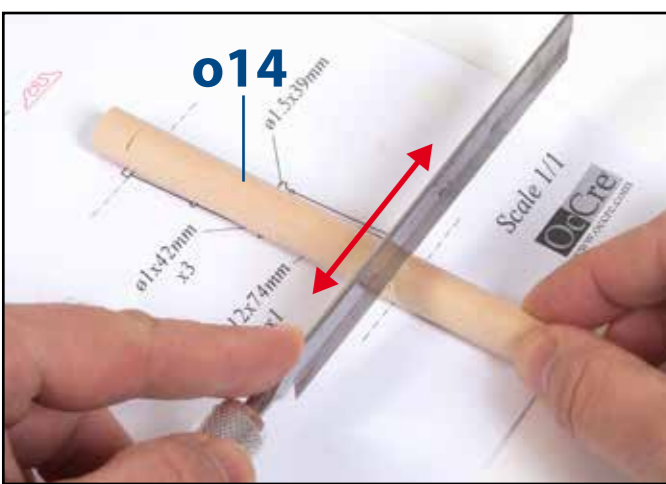
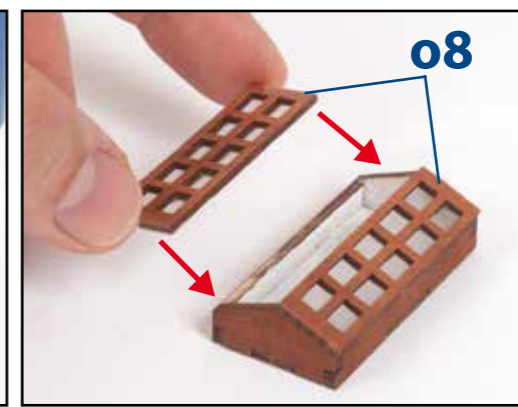
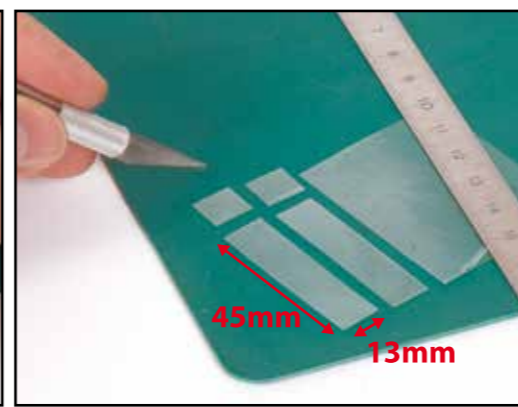
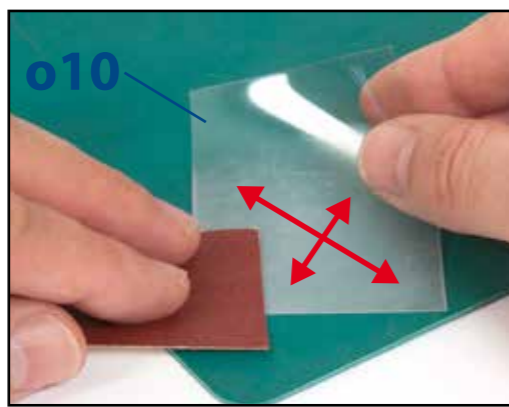
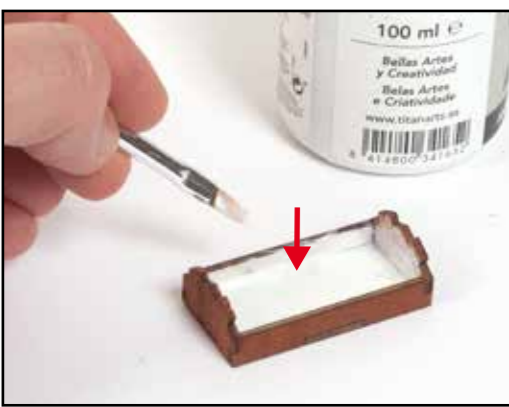
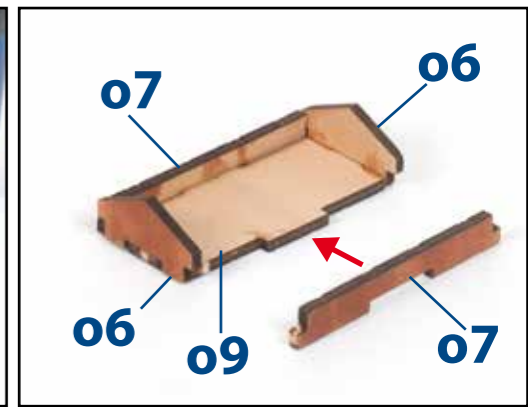
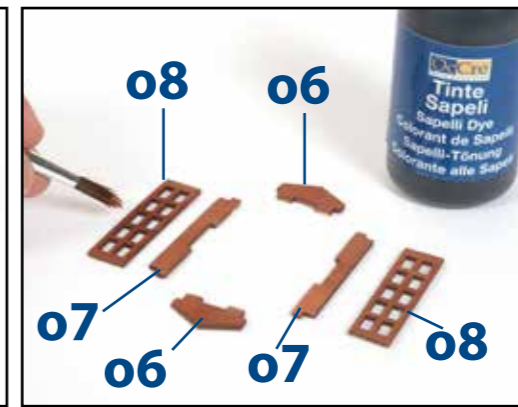
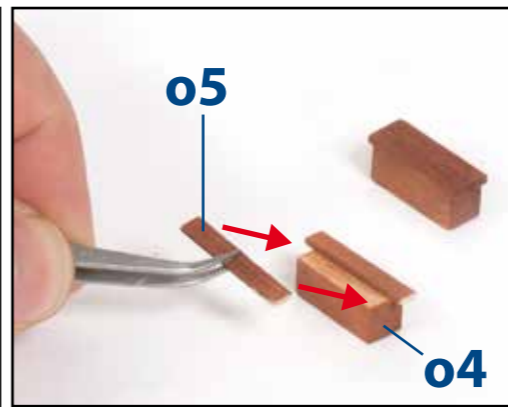
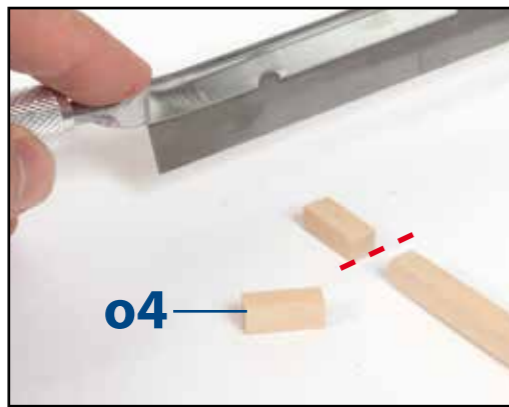
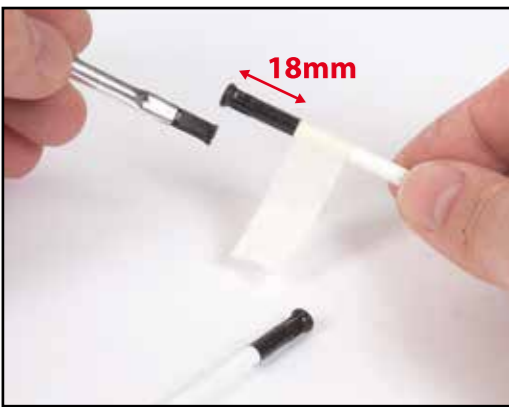
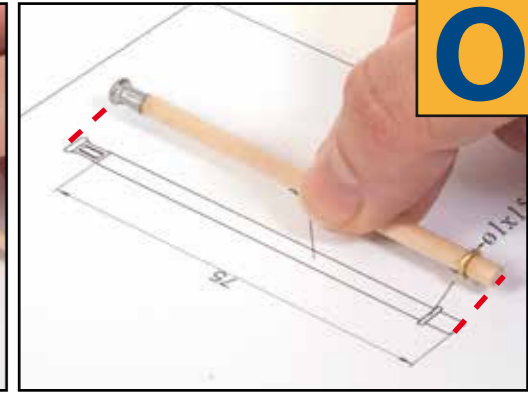
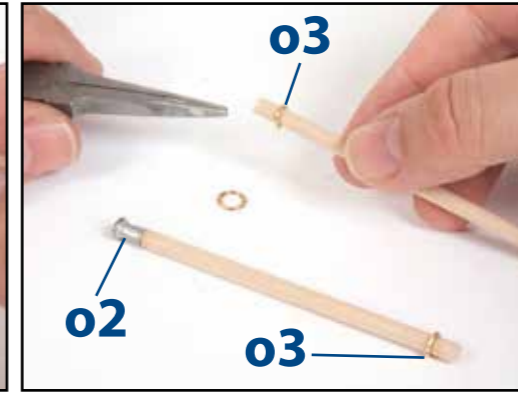
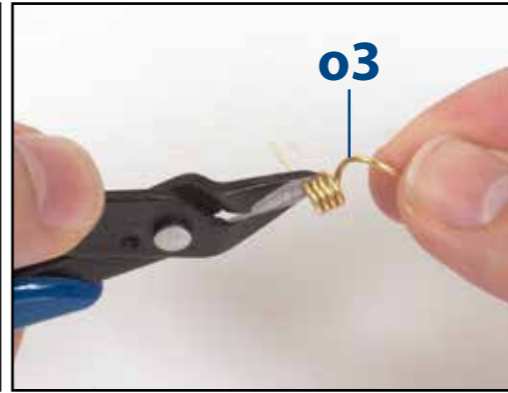
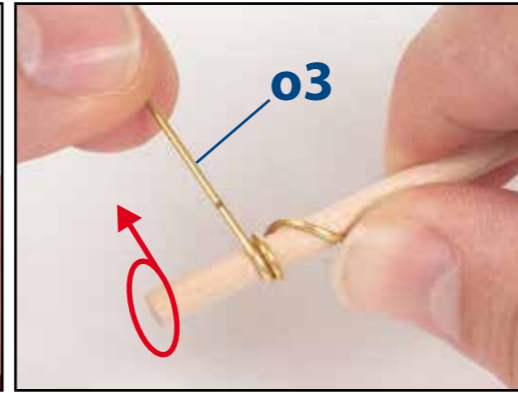
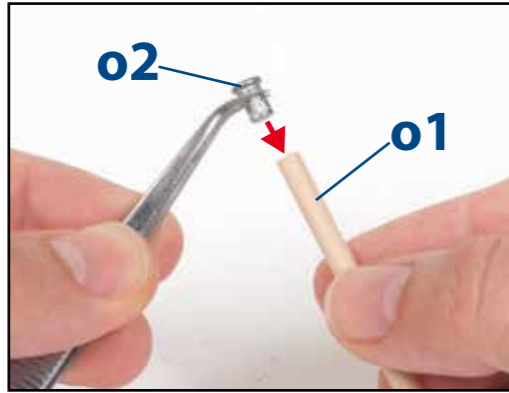
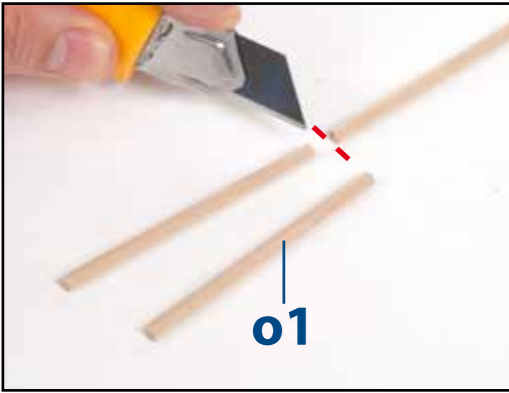

P

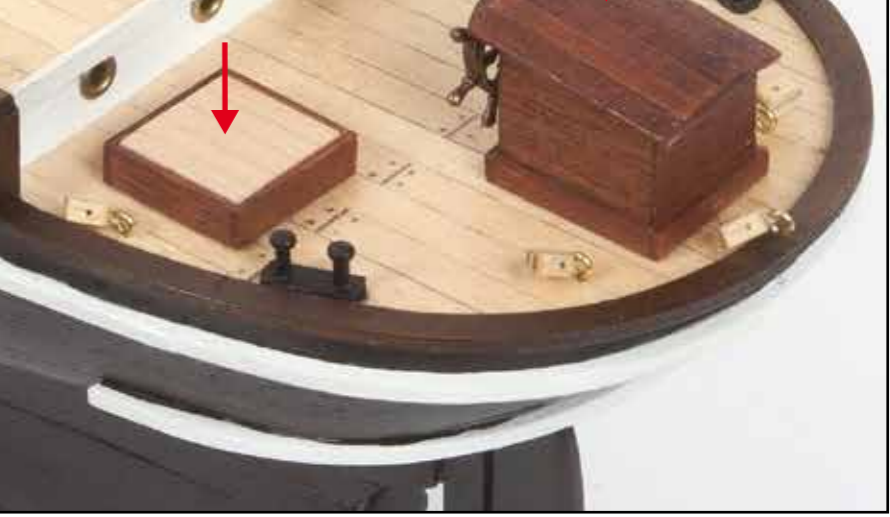
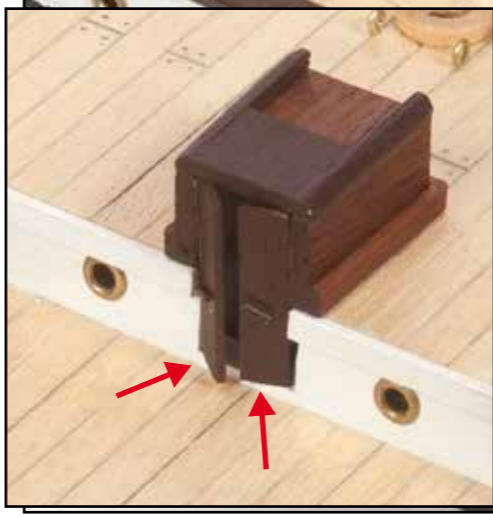
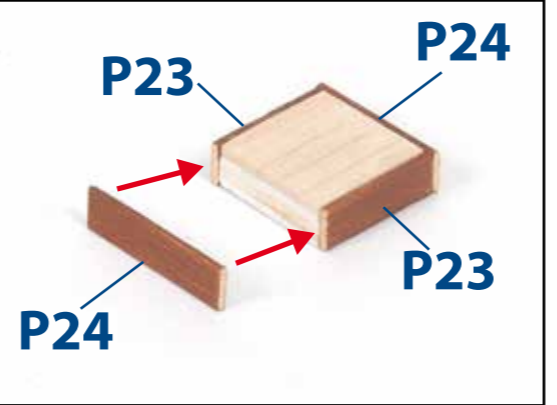
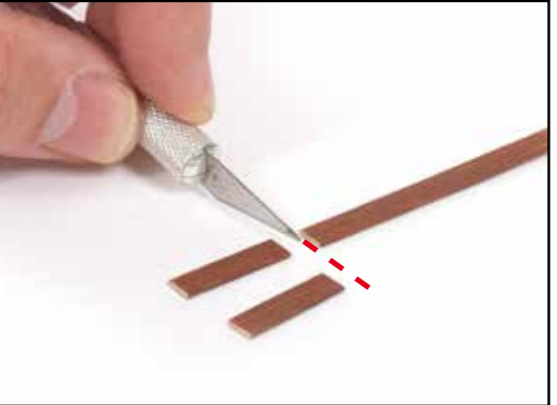
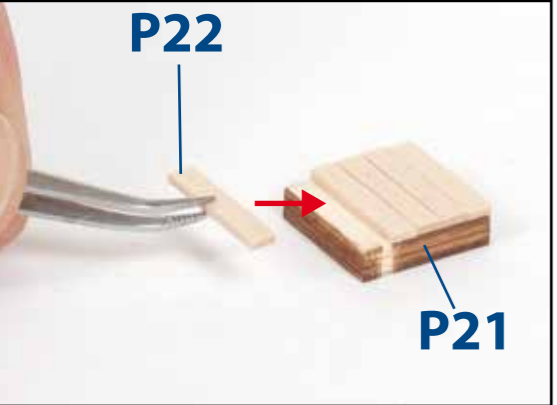
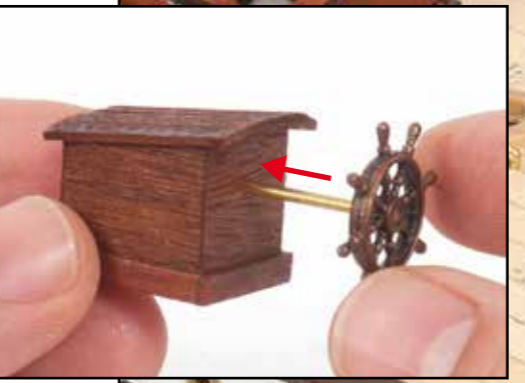
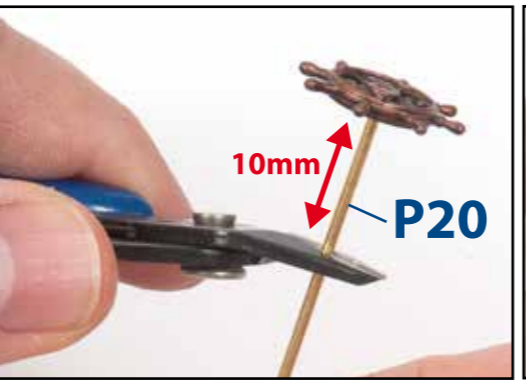
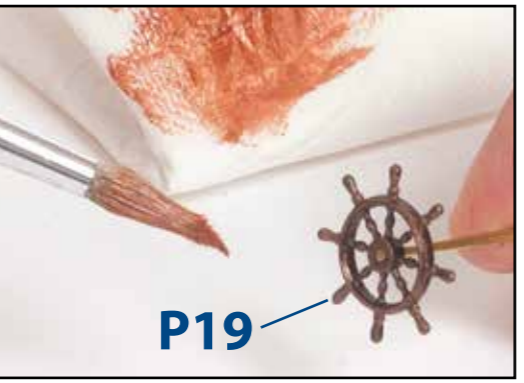
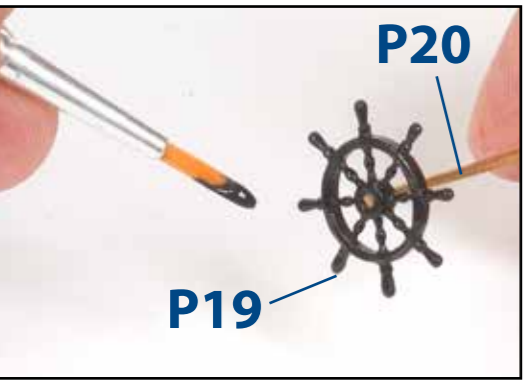
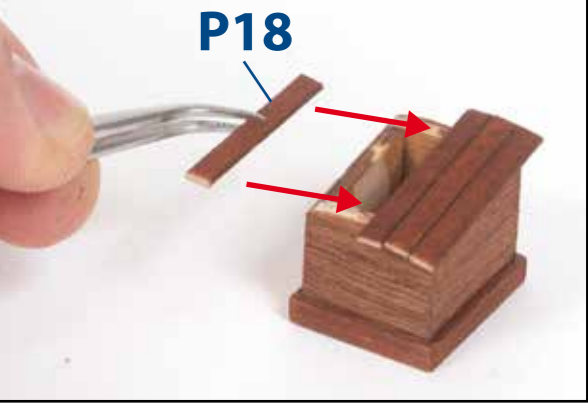
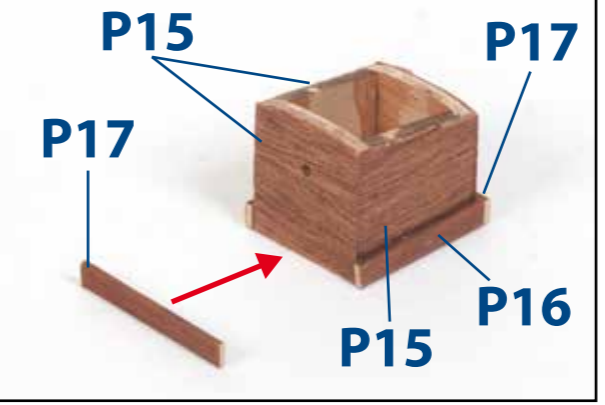
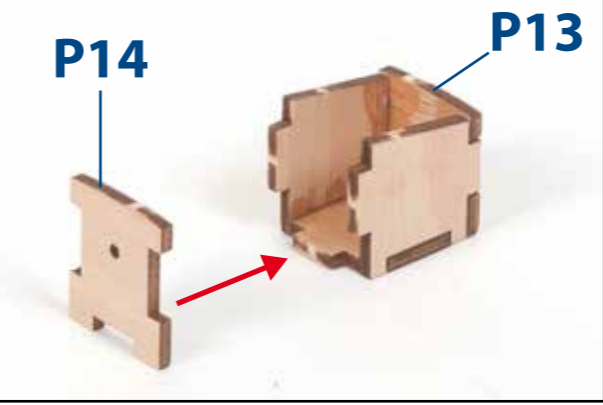
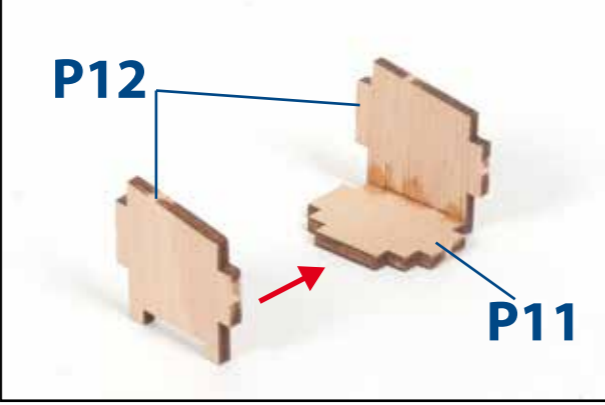
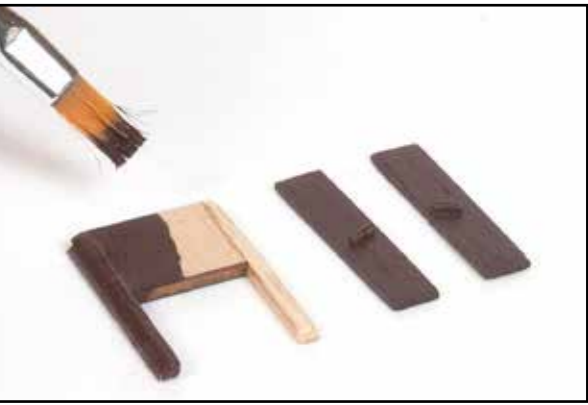
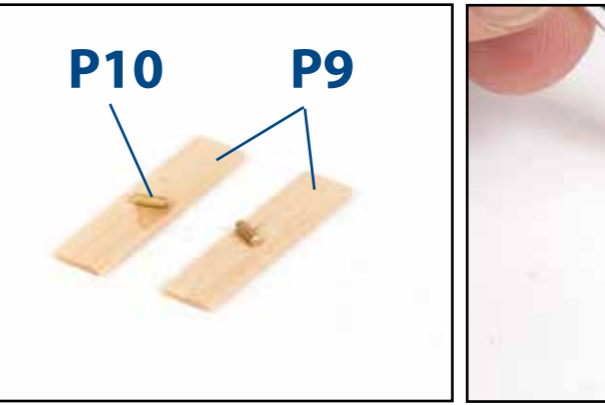
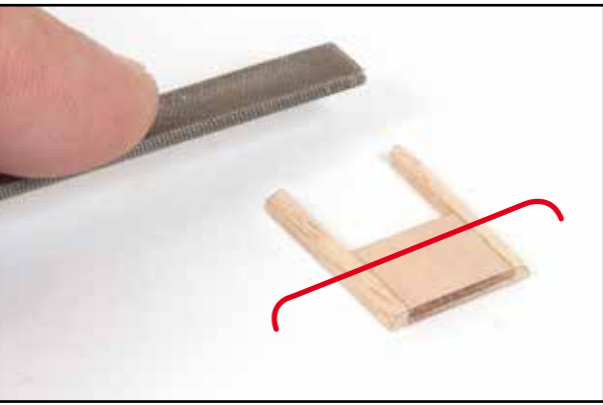
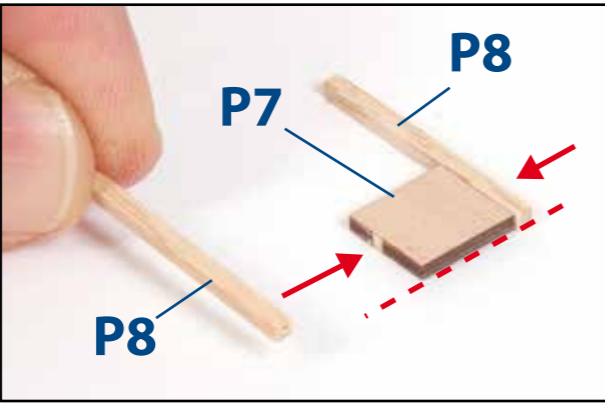
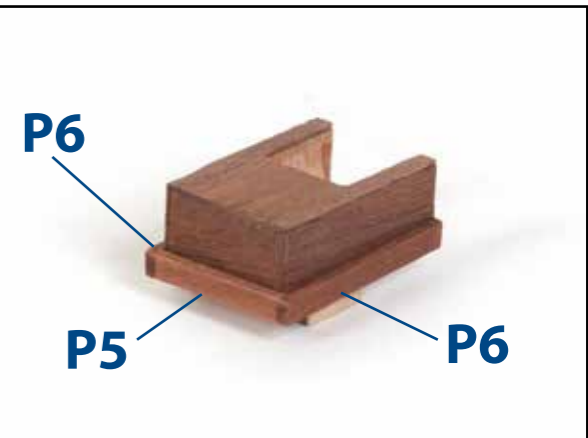
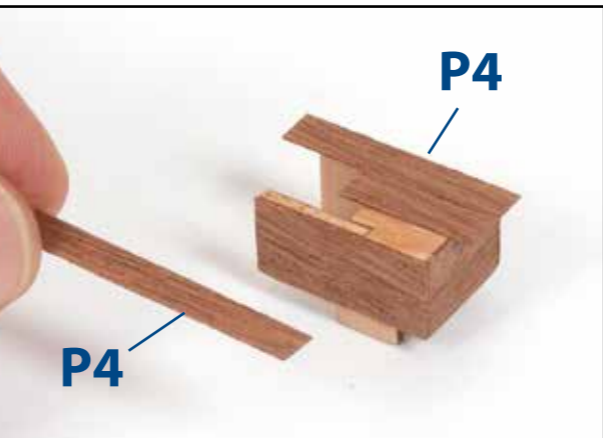
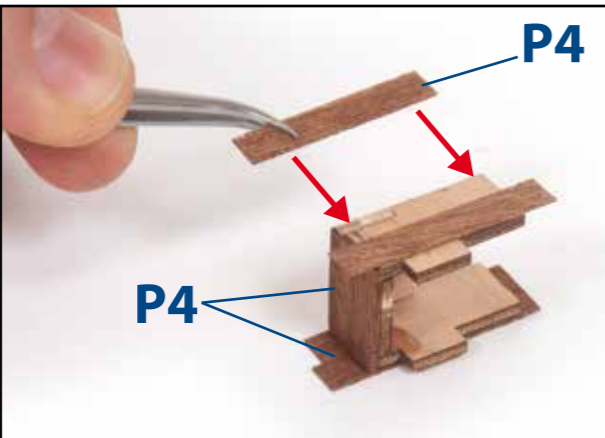
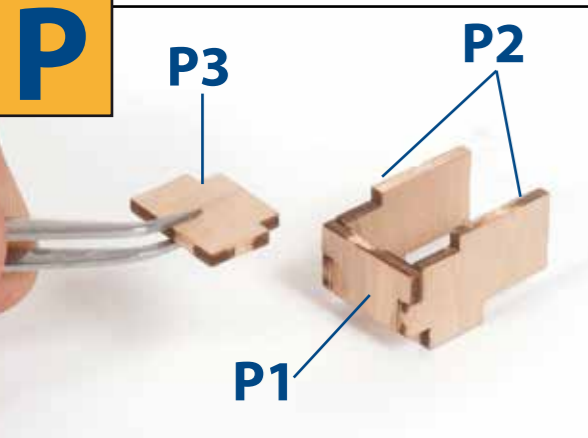

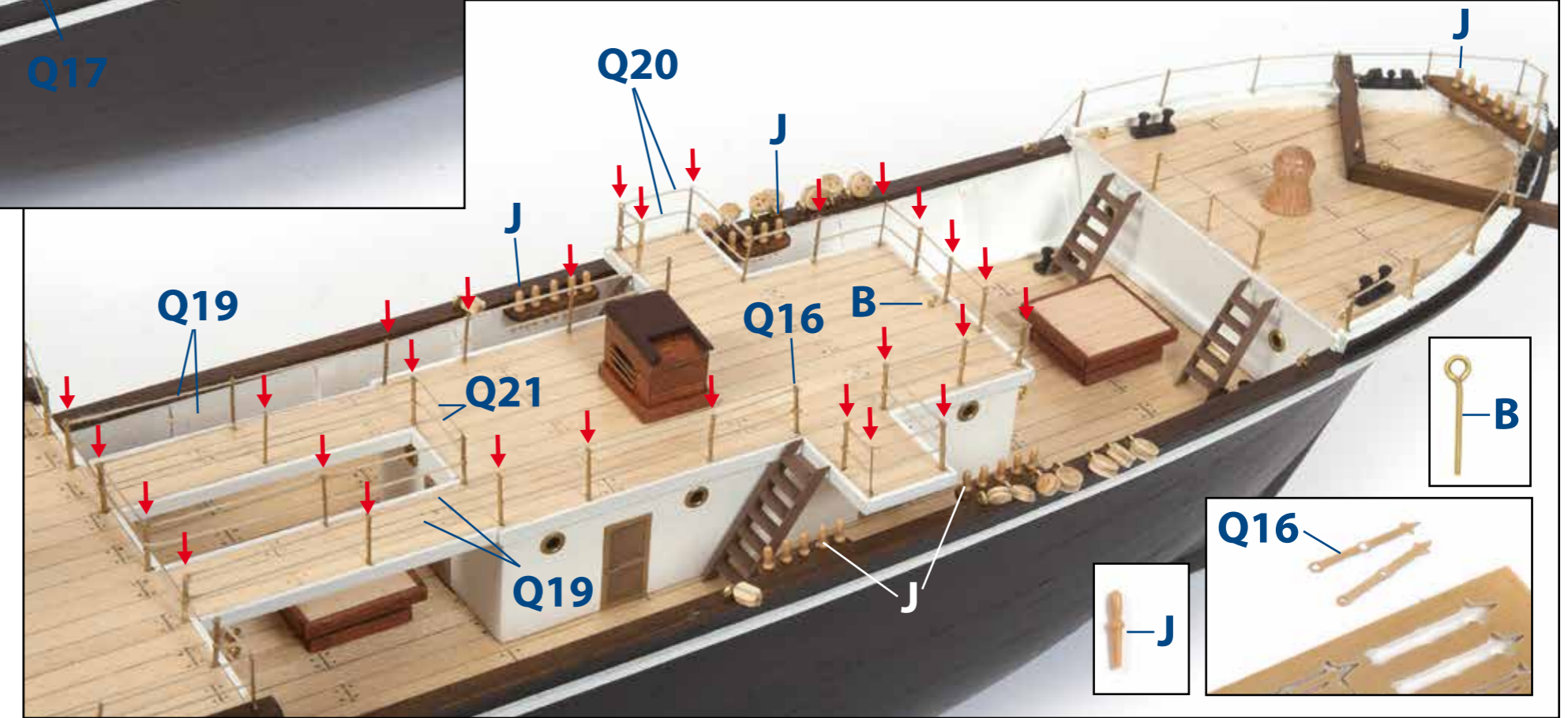
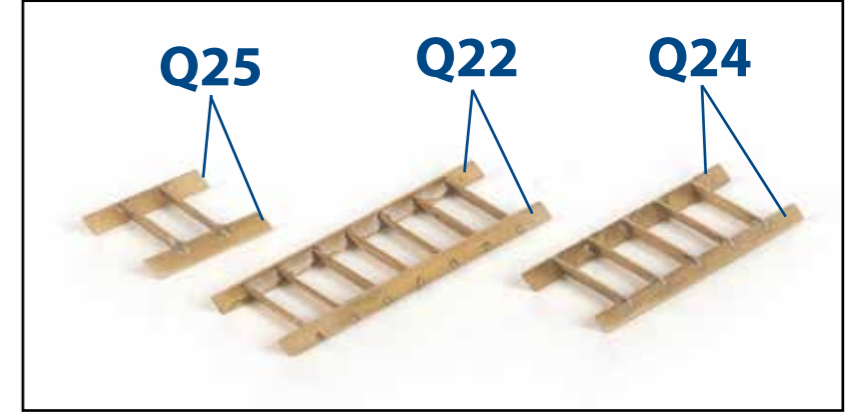
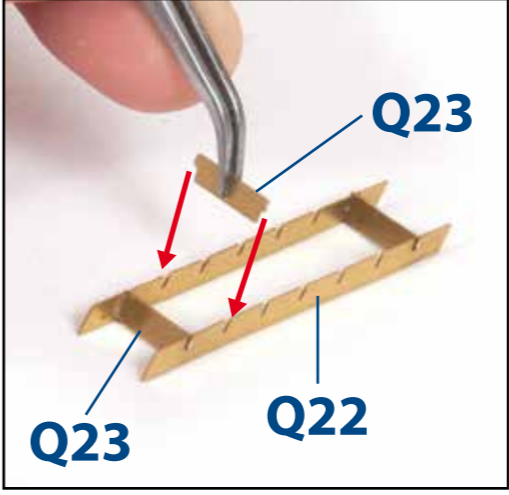
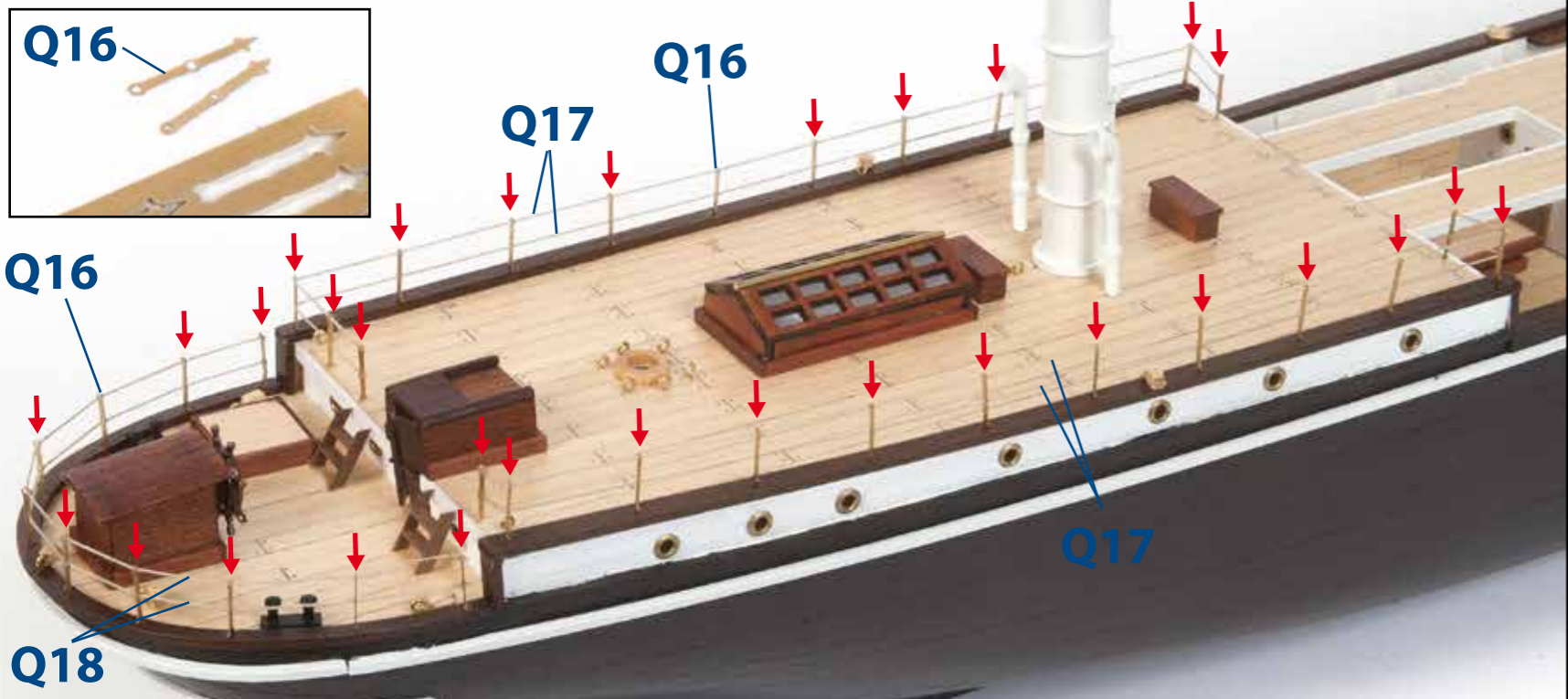
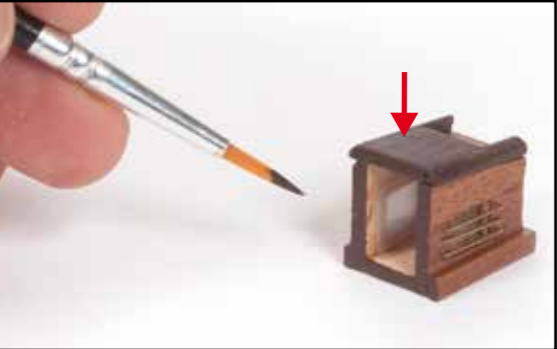
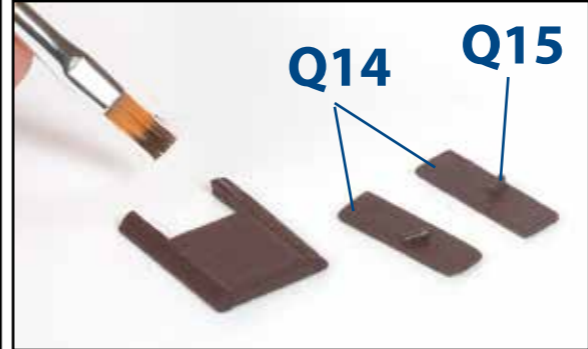
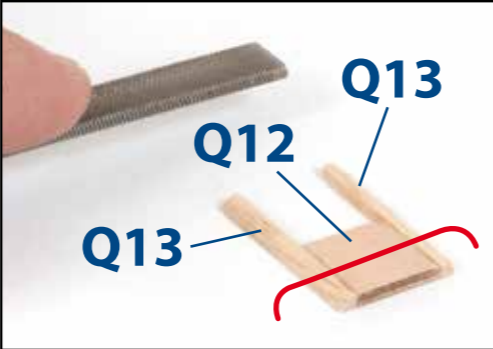
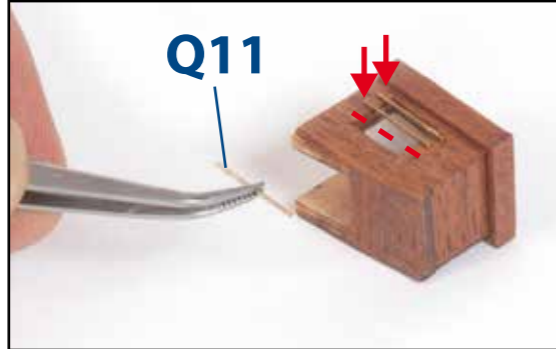
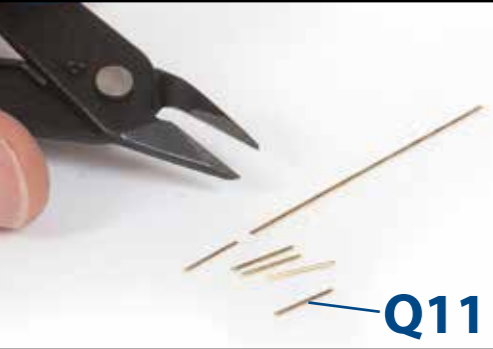
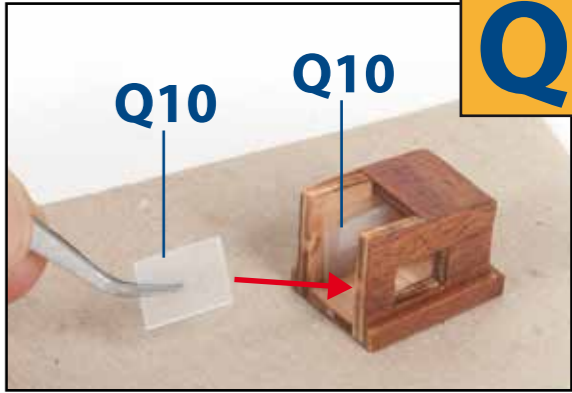
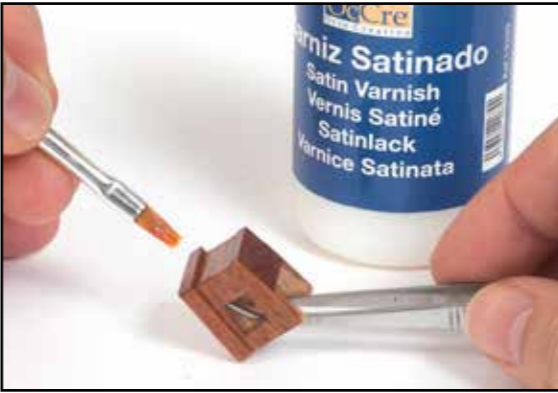
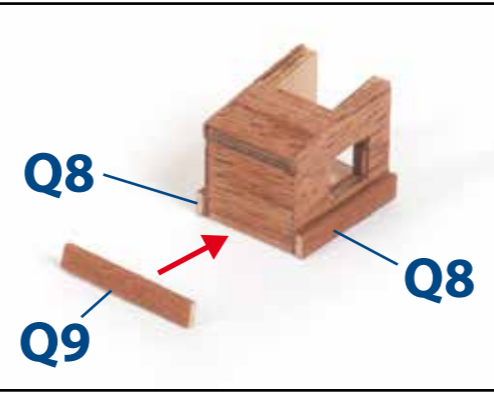
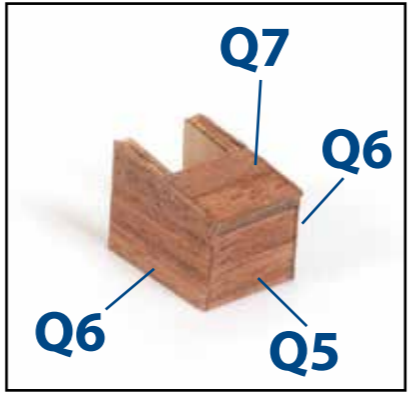
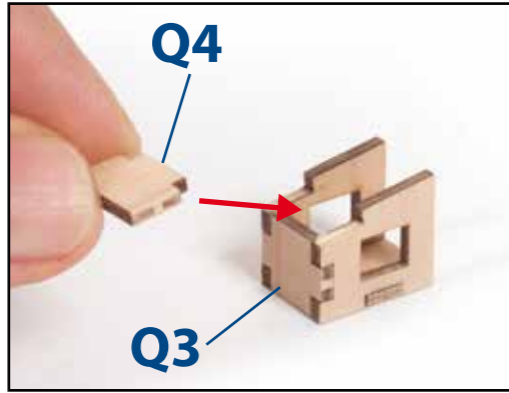
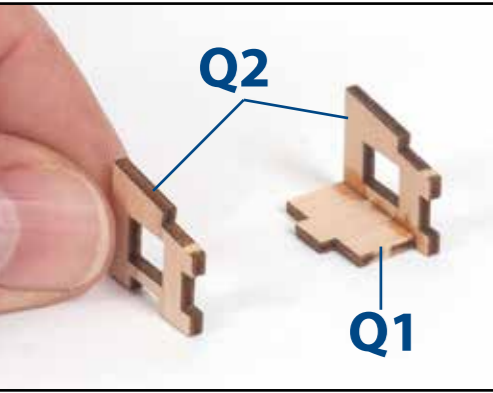

R

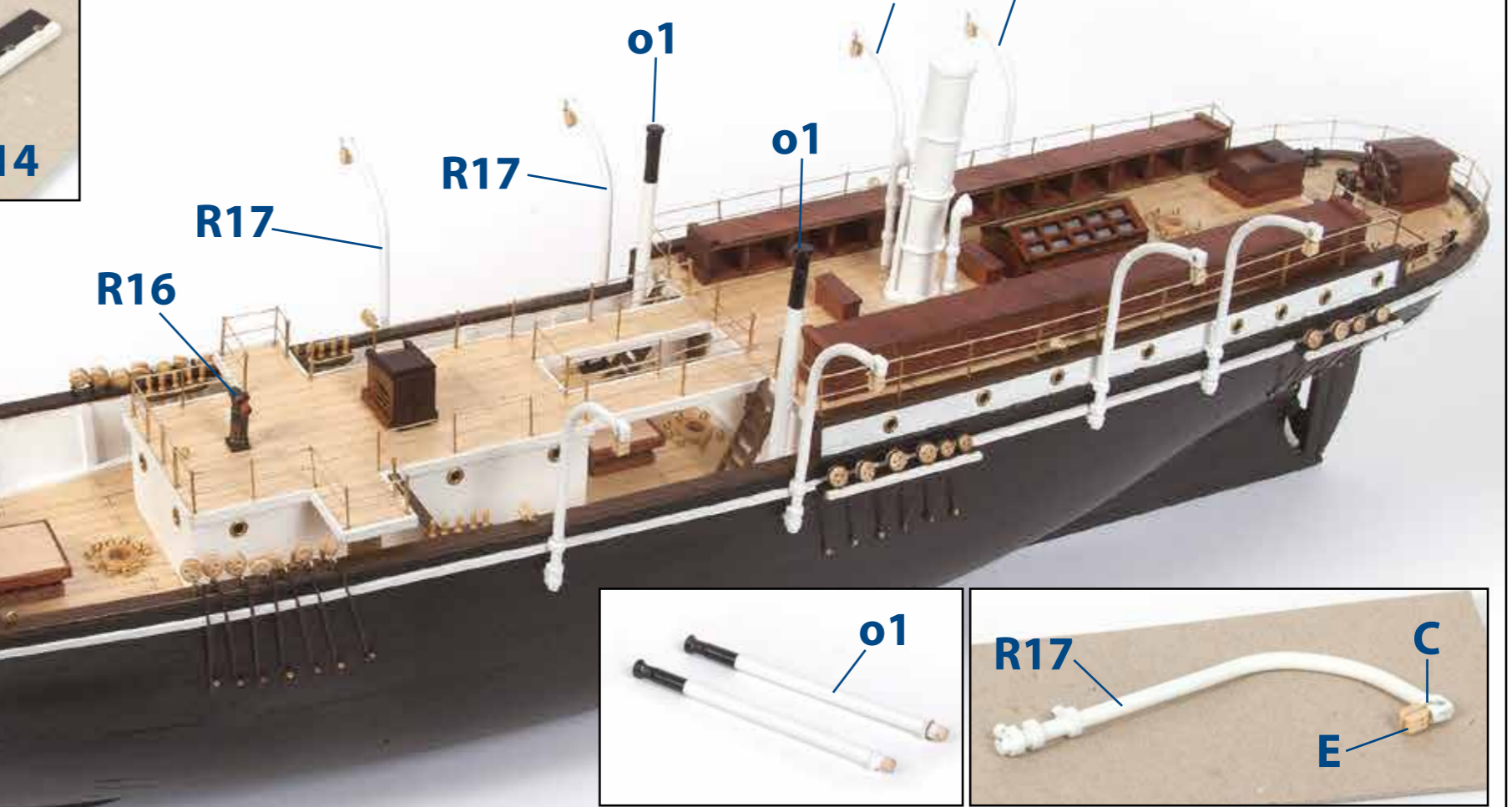
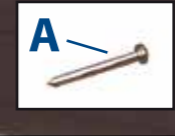
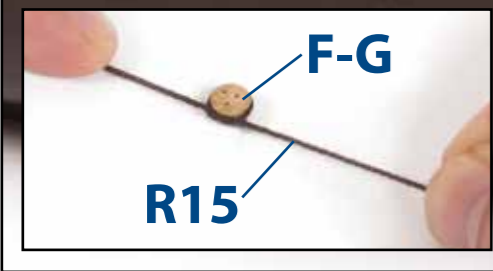
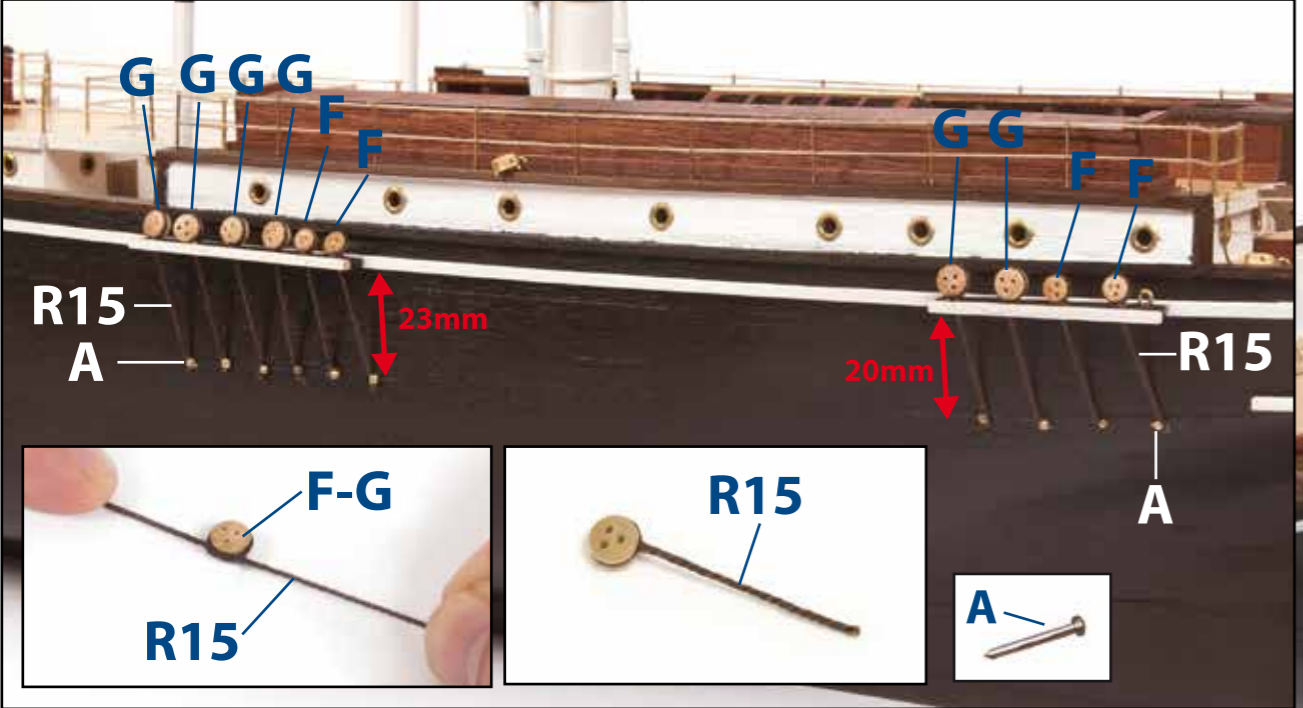
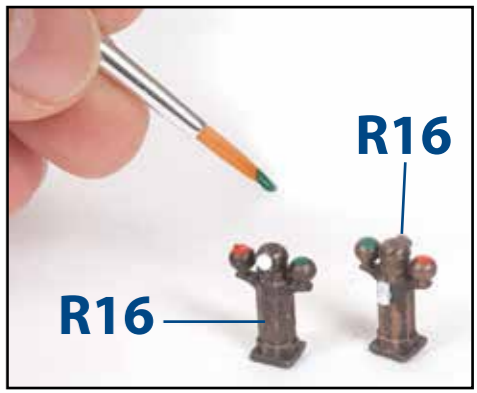
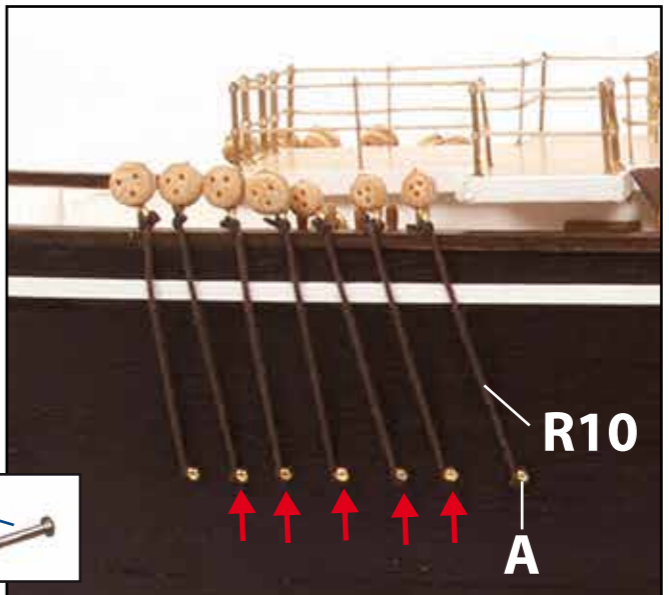
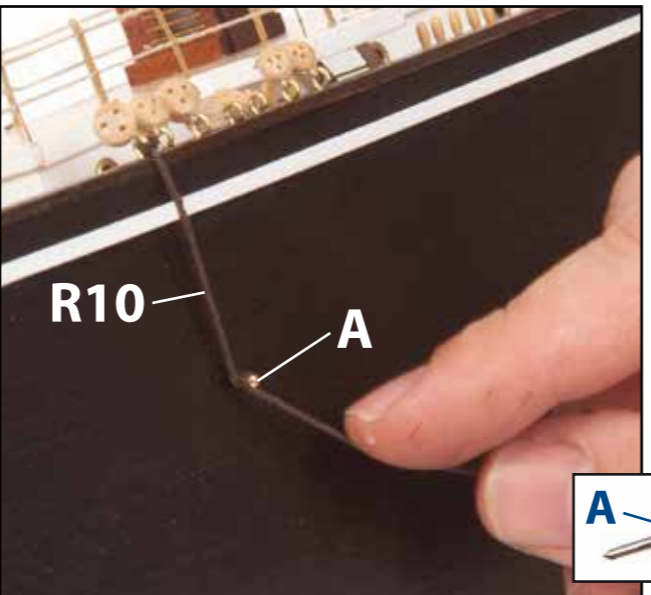
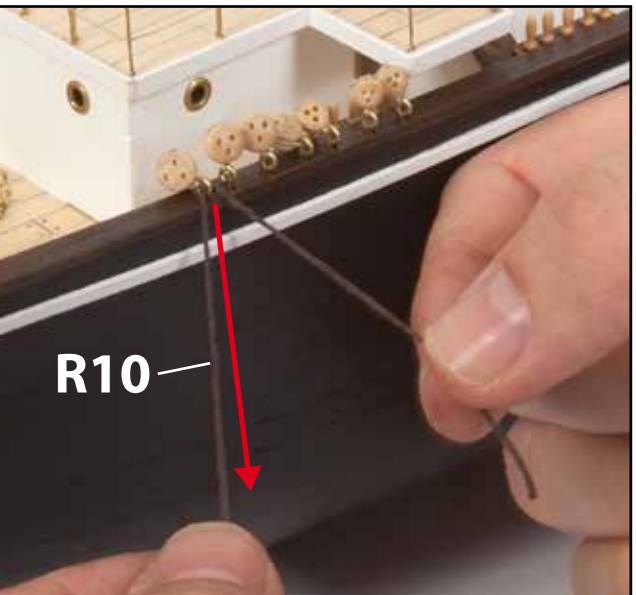
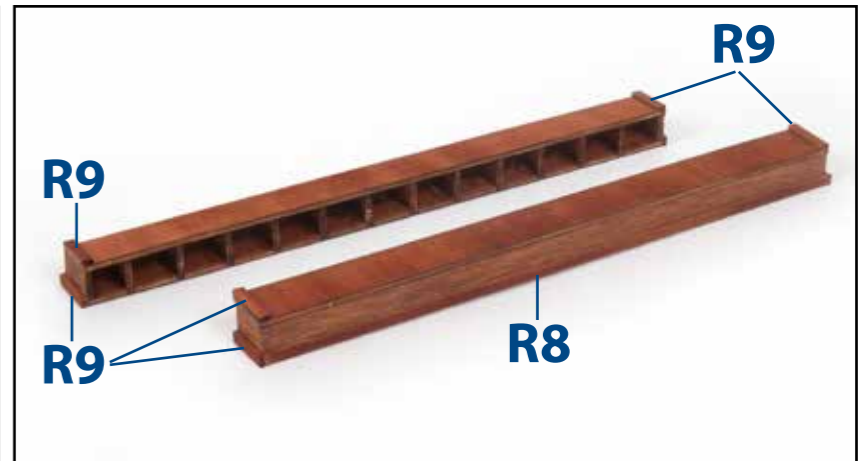
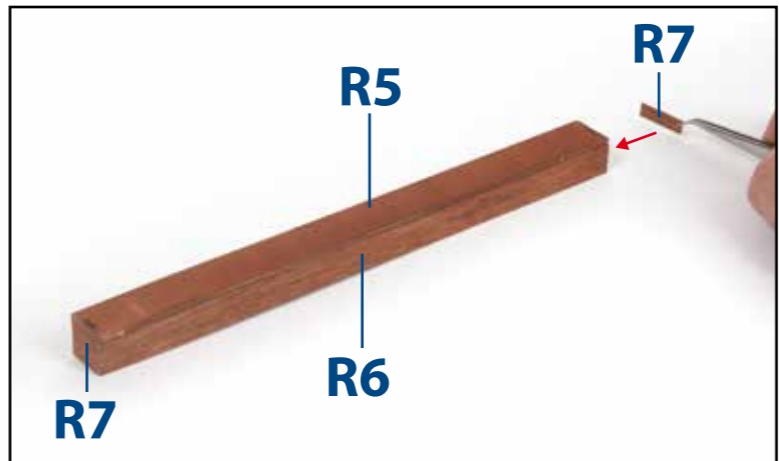
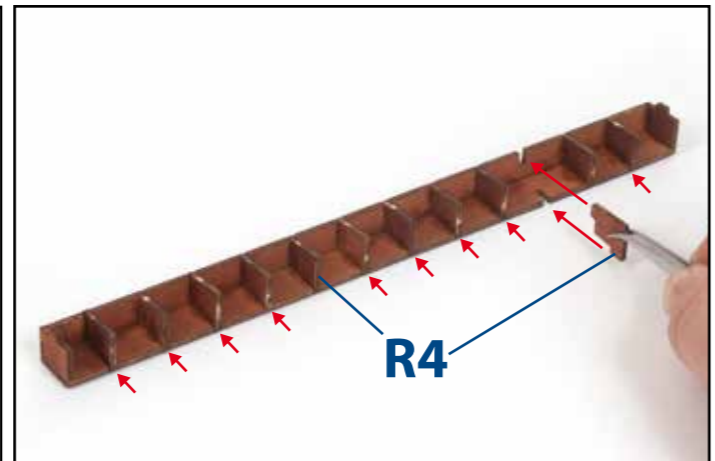
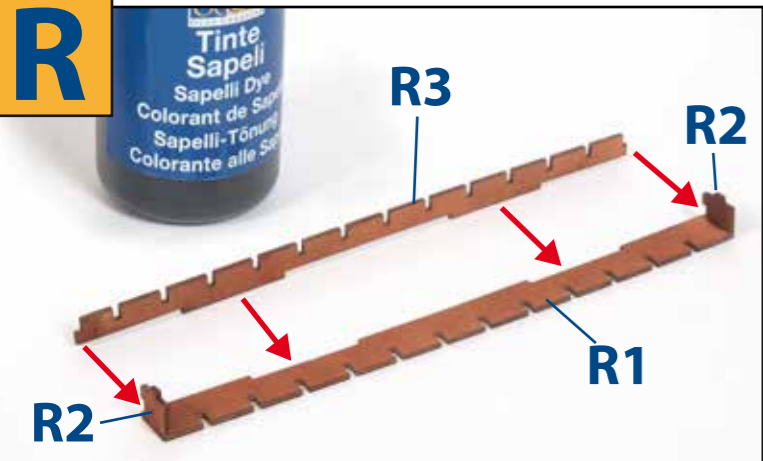

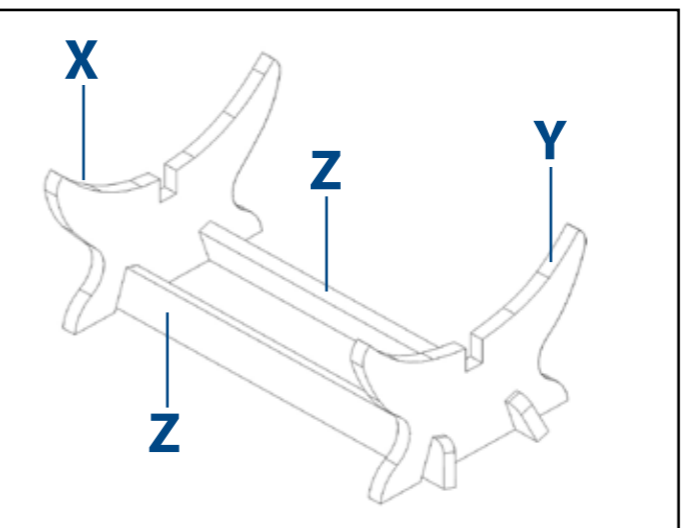
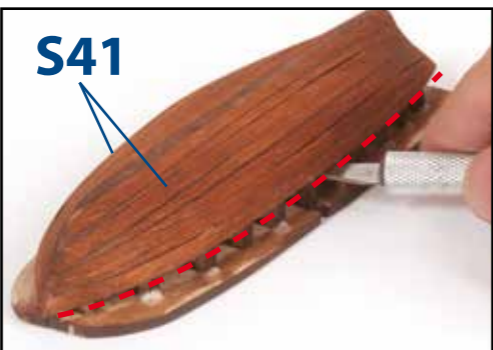
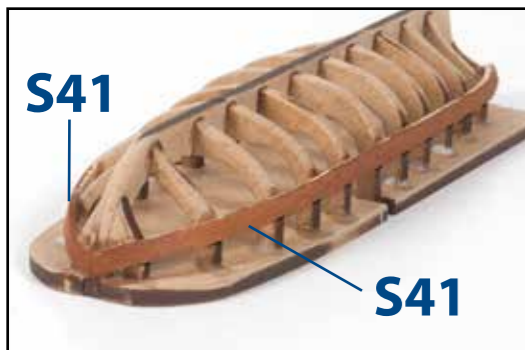
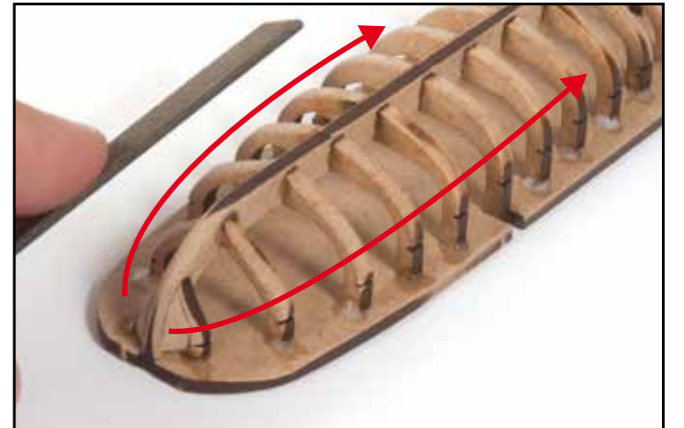
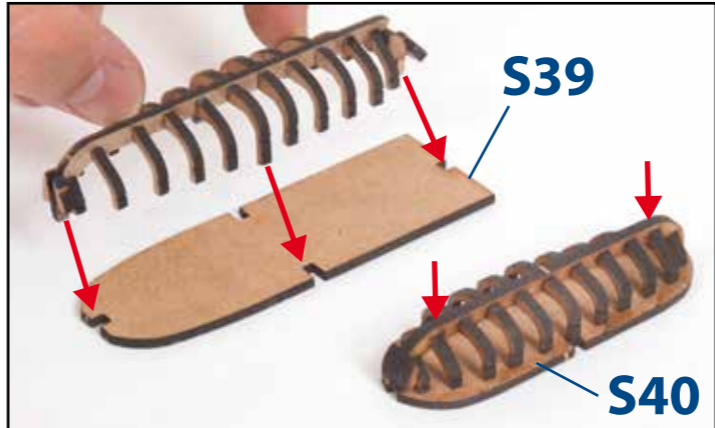
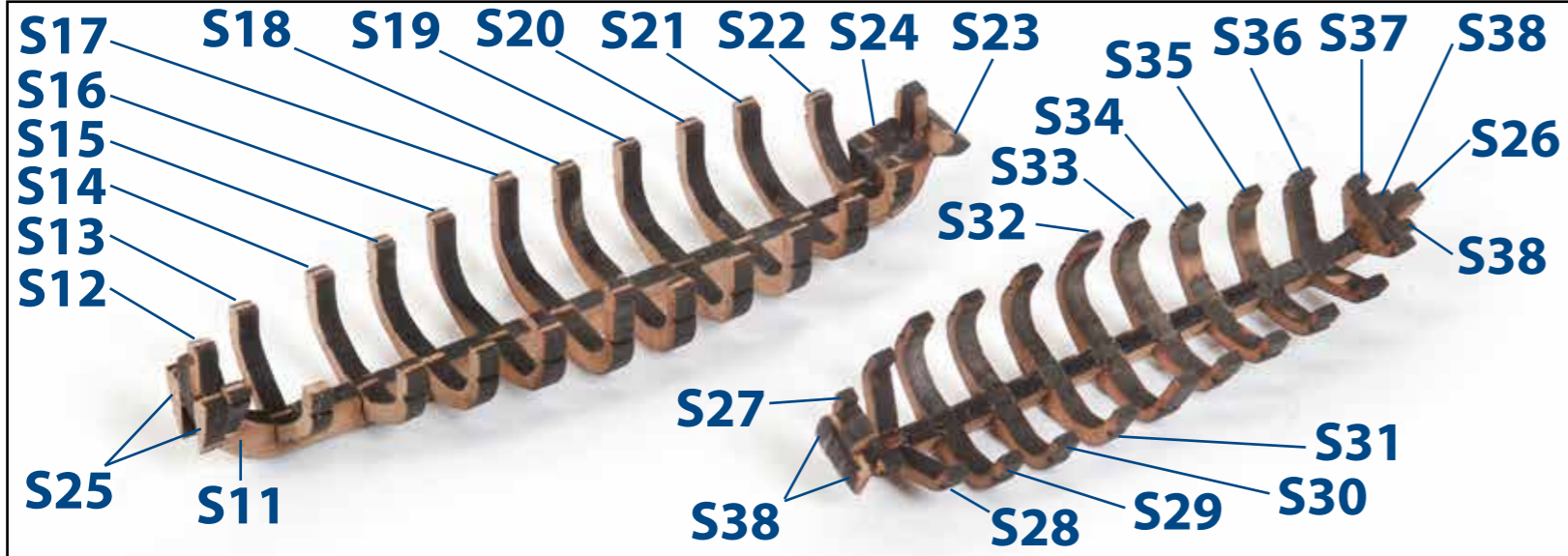
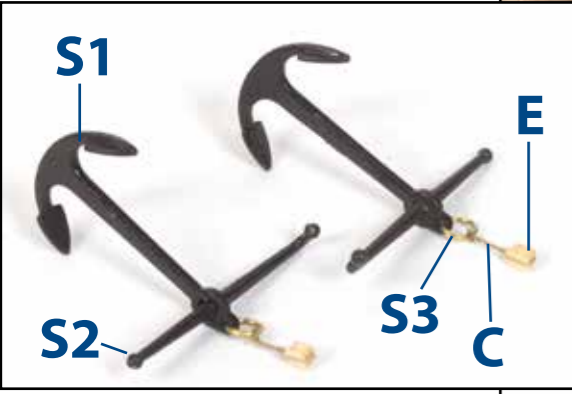
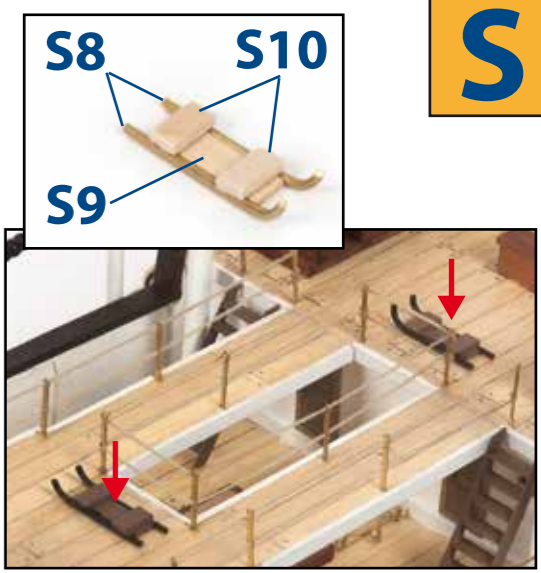
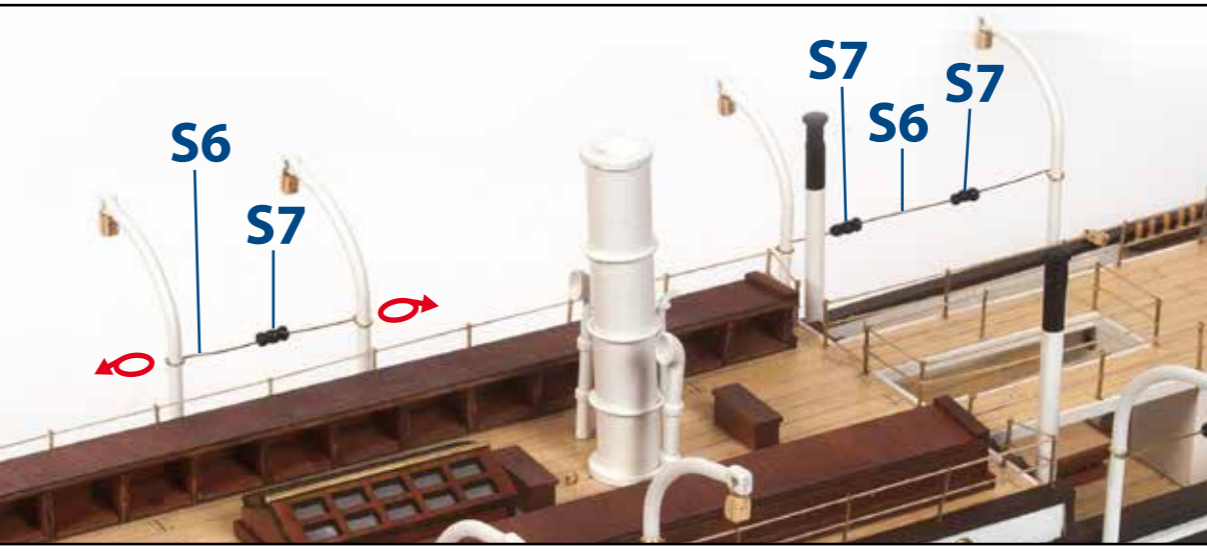
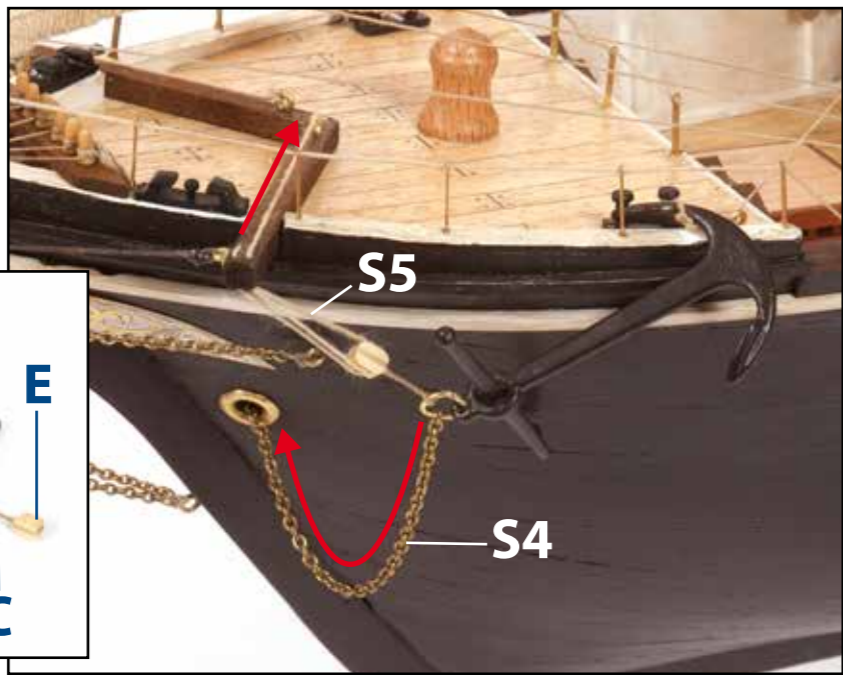
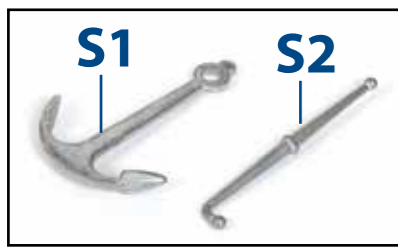

T

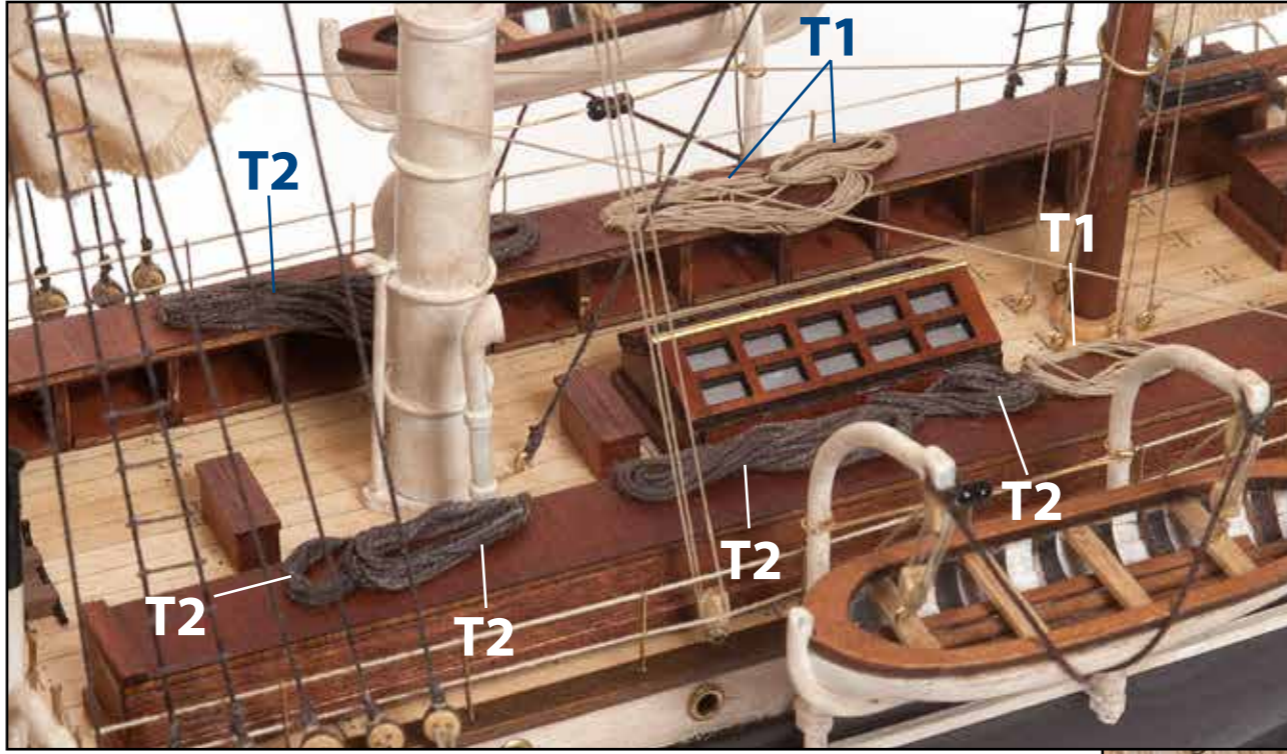

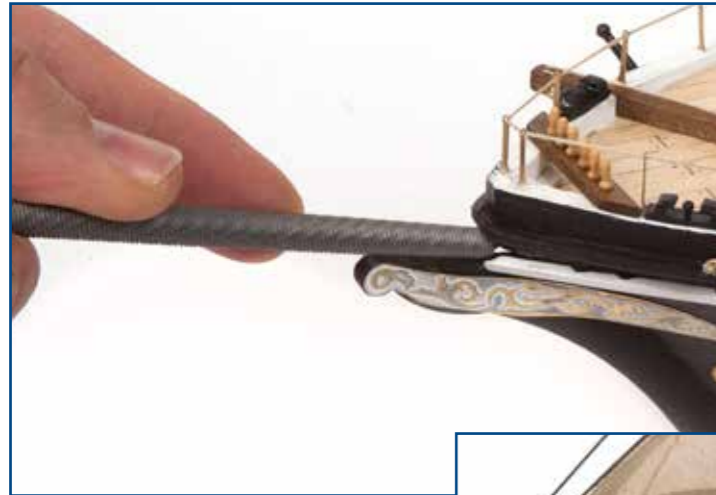
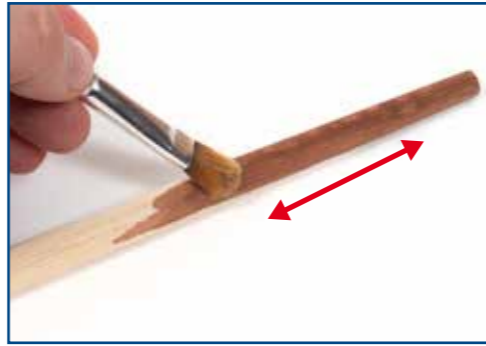
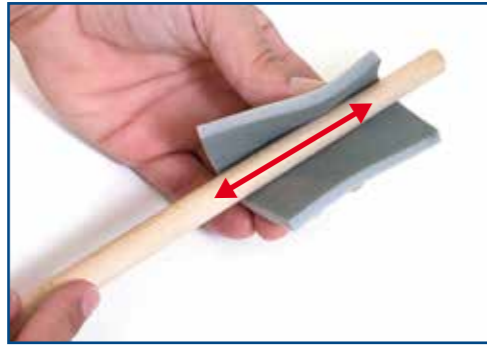
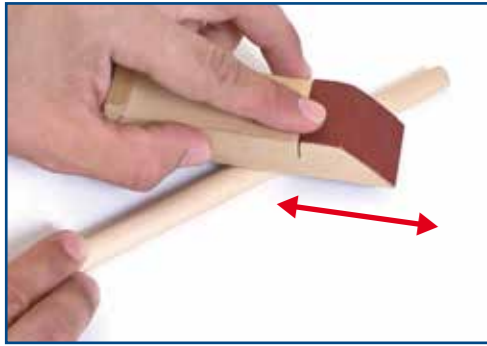

Consultar los planos de mástiles
Consult the masts drawings
Consulte os desenhos dos mastros
Consulter les dessins des mâts
Konsultieren Sie die Mastenzeichnungen
Обратитесь к рисункам мачты
Consultare i disegni degli alberi

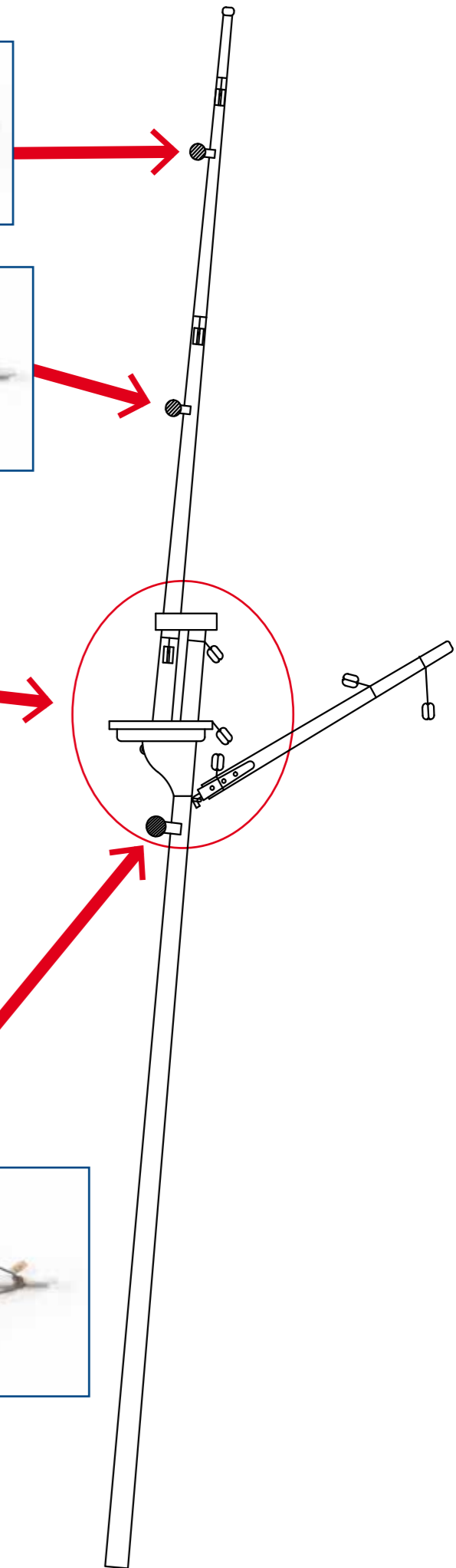
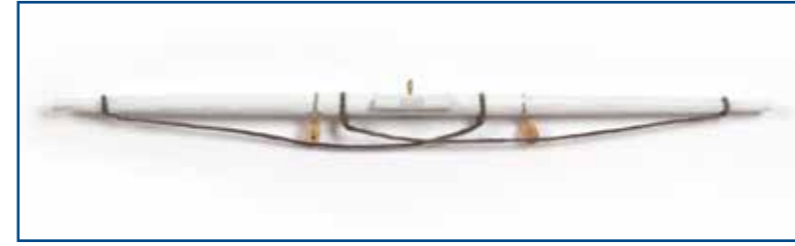
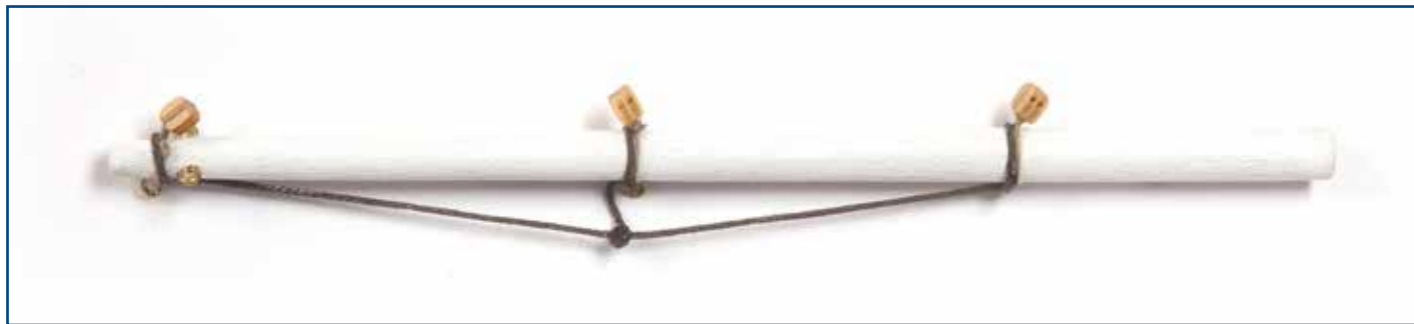
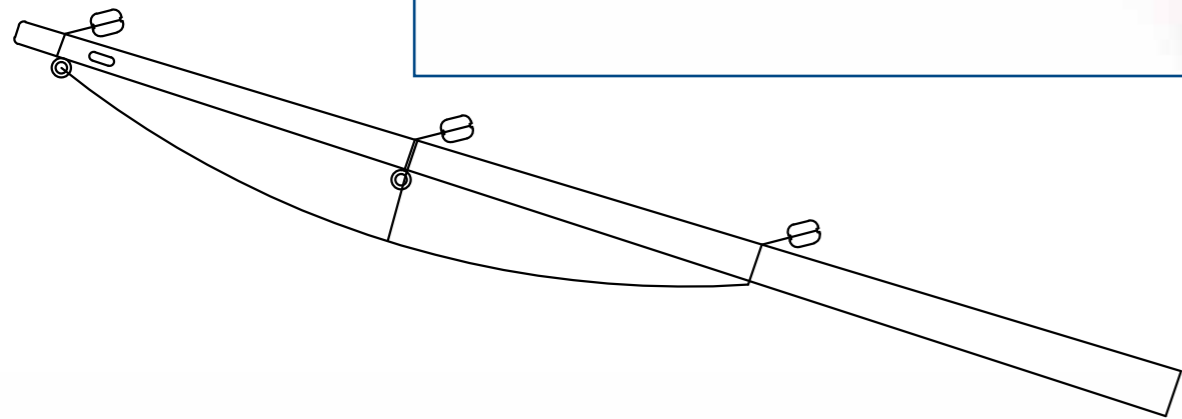

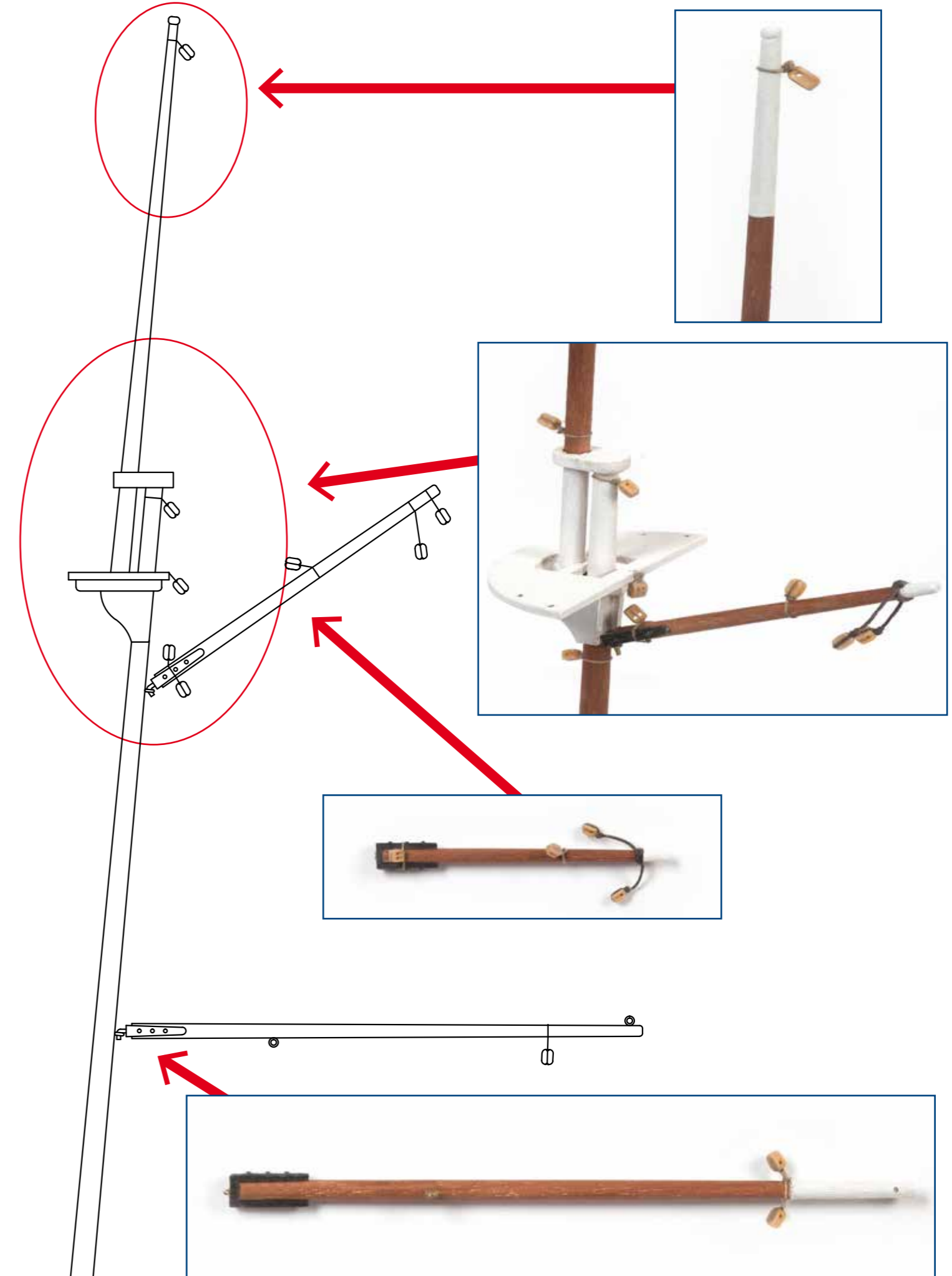
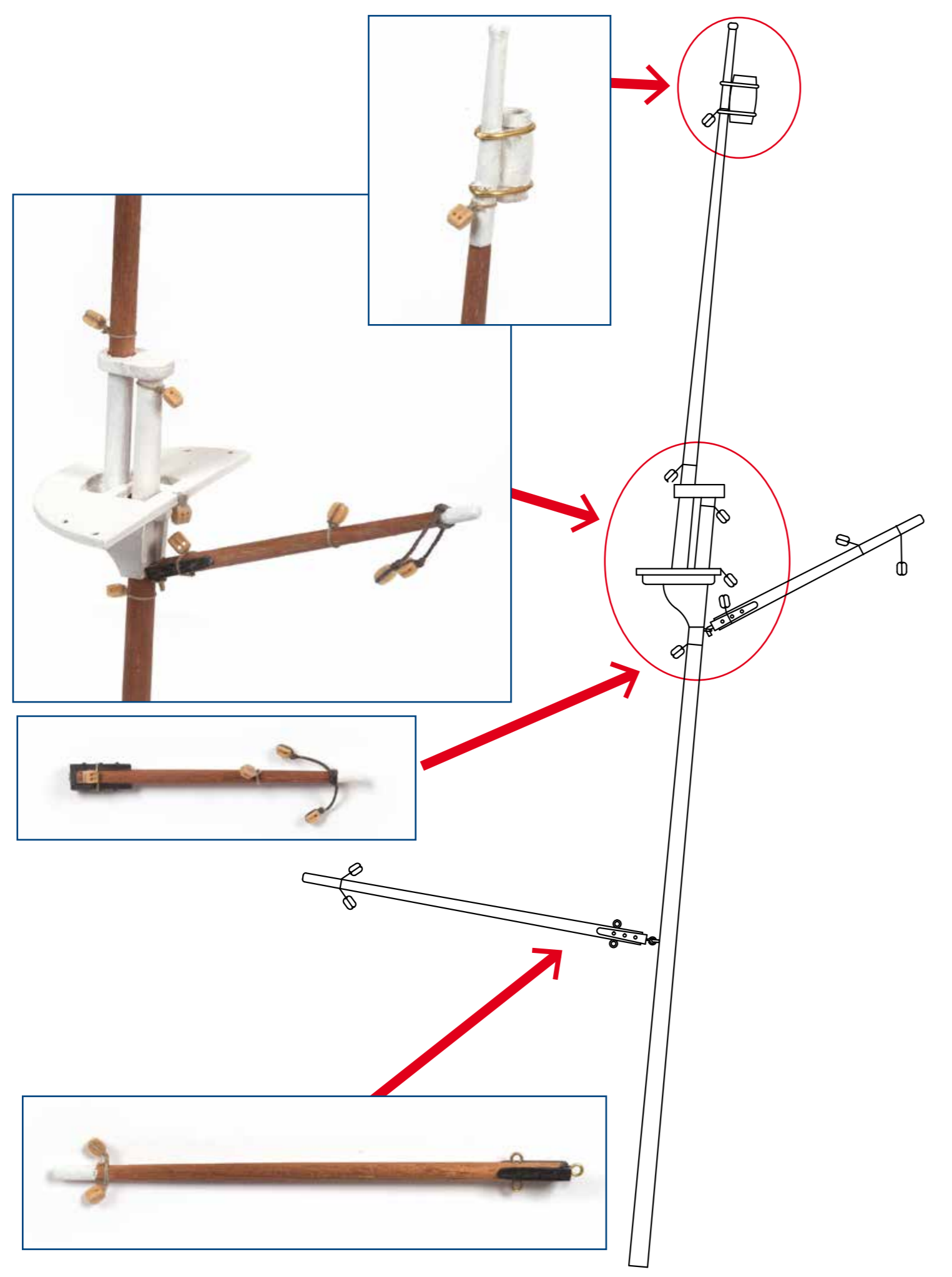

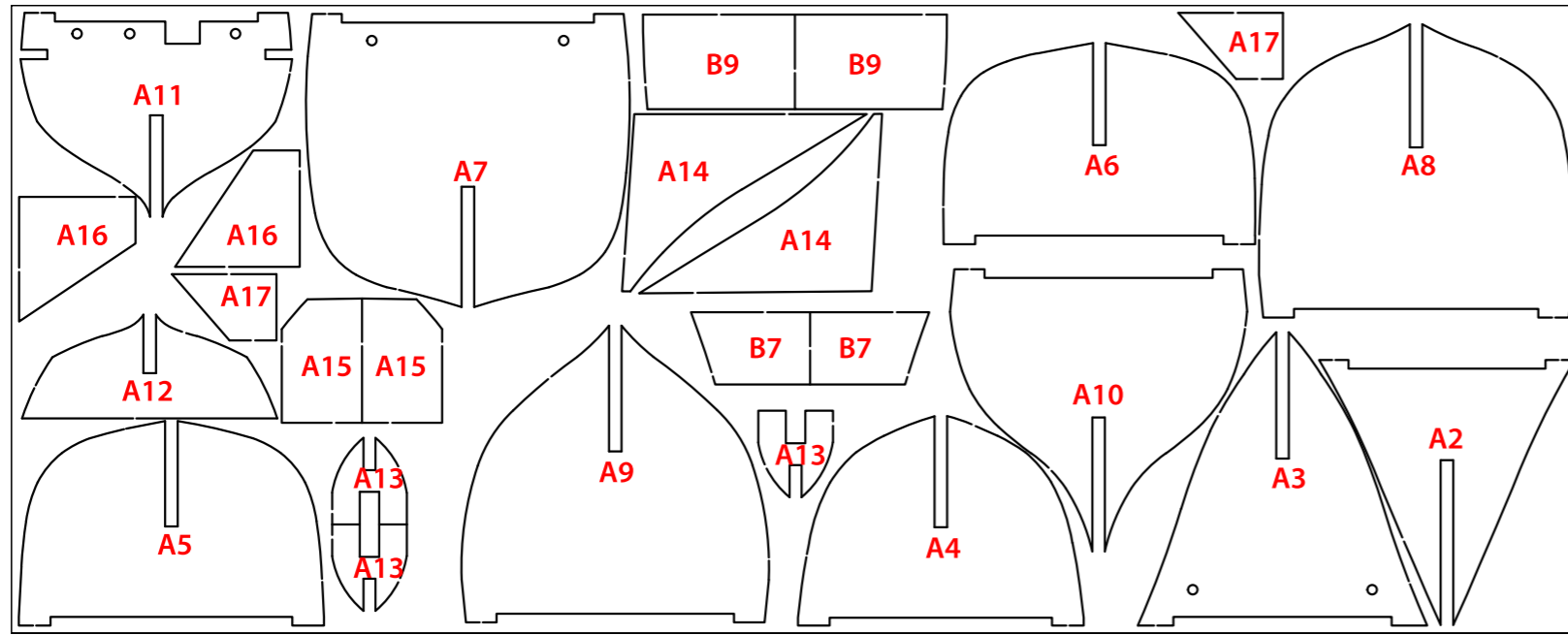

12008-2

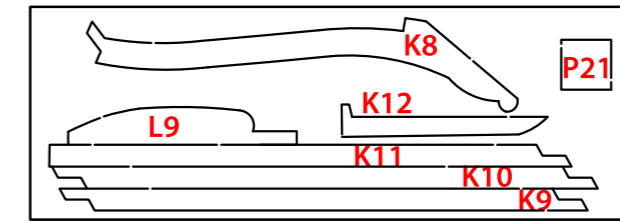

12008-4

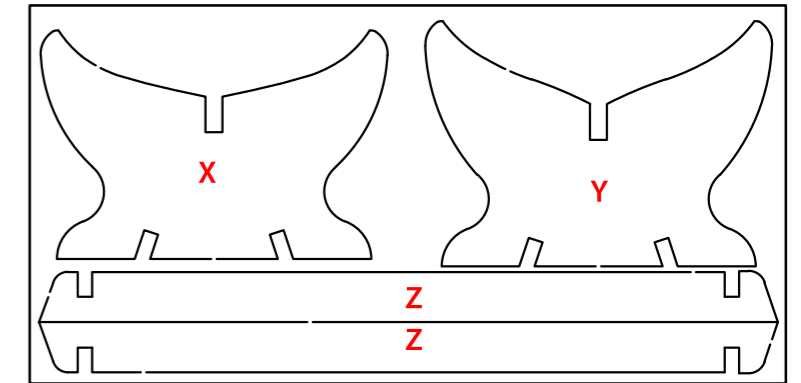

12008-11

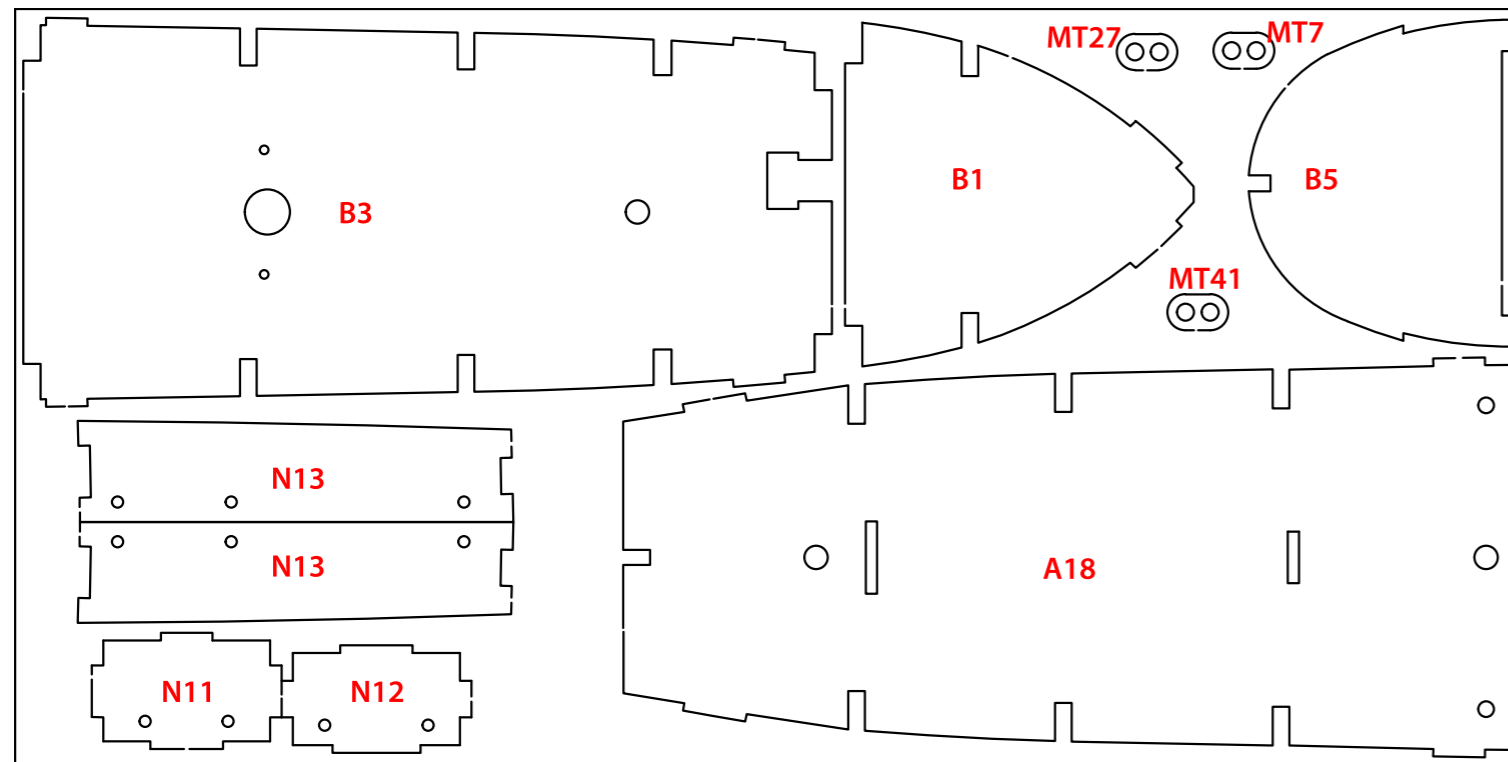

12008-3

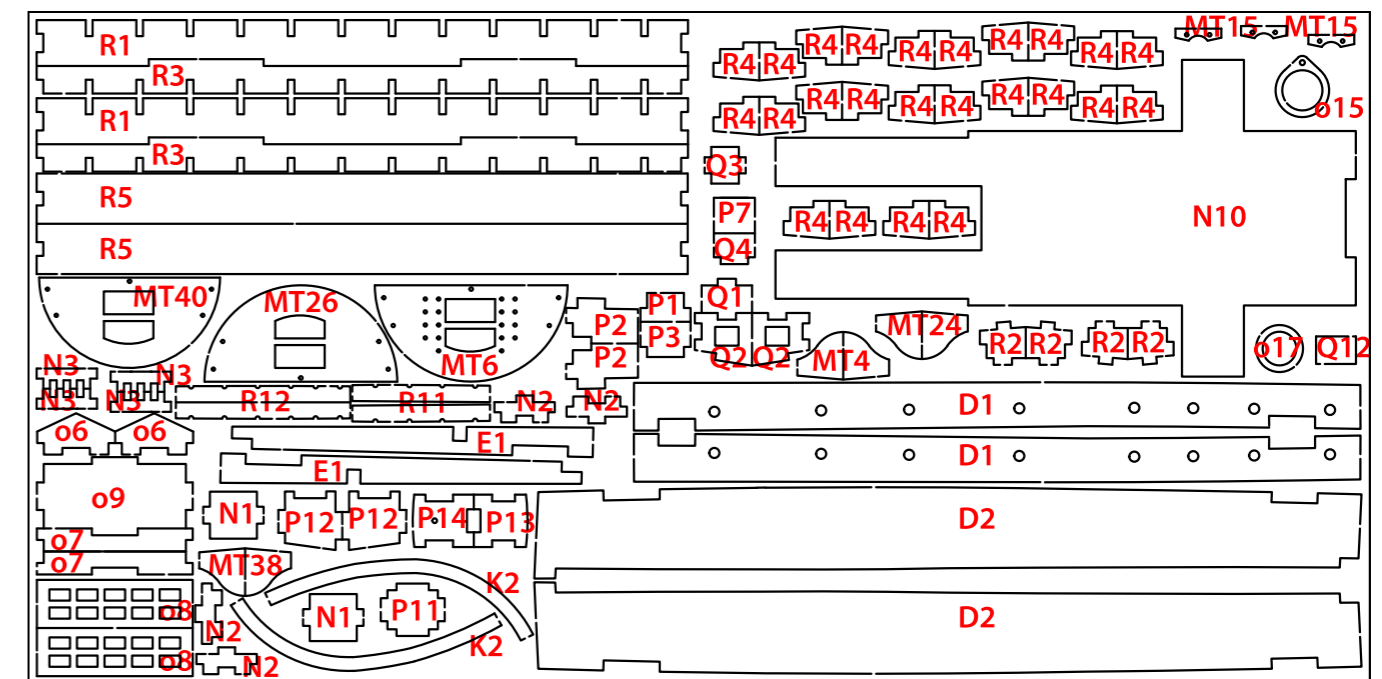

12008-5

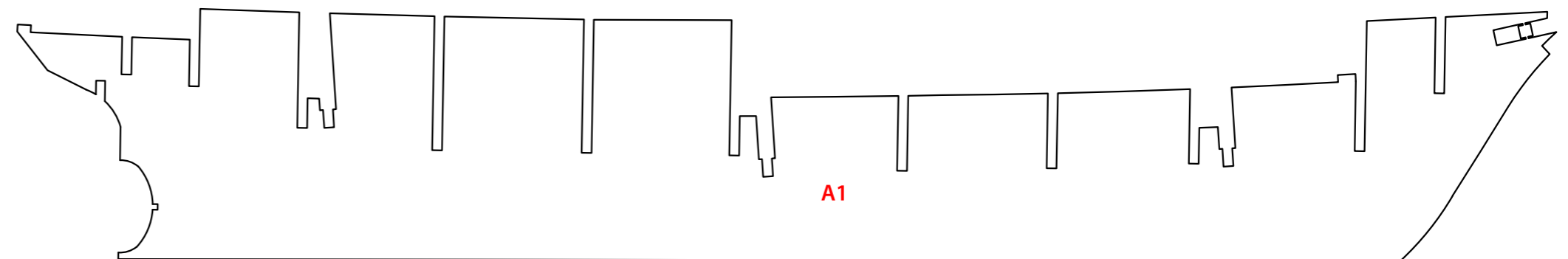

12008-1



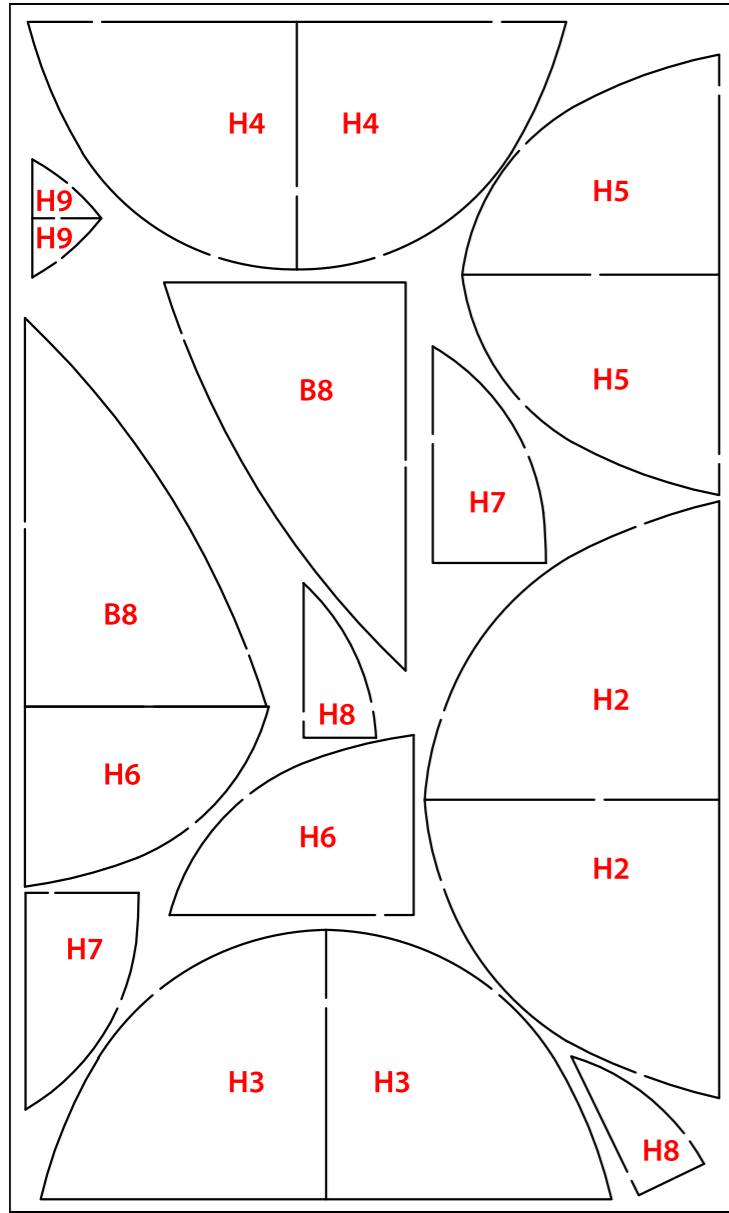

12008-6

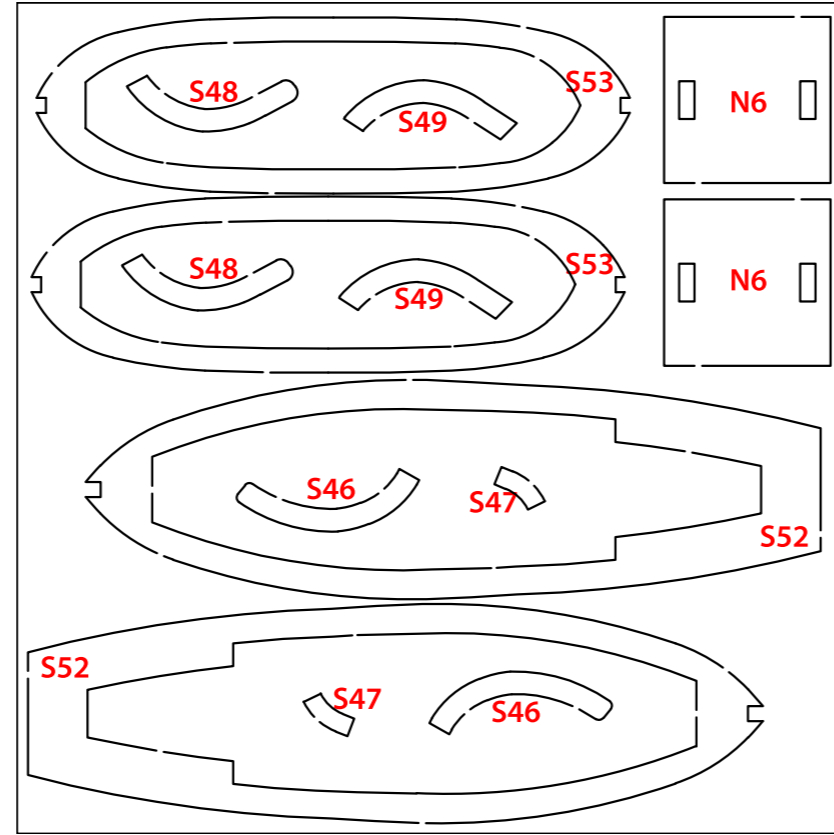

12008-8

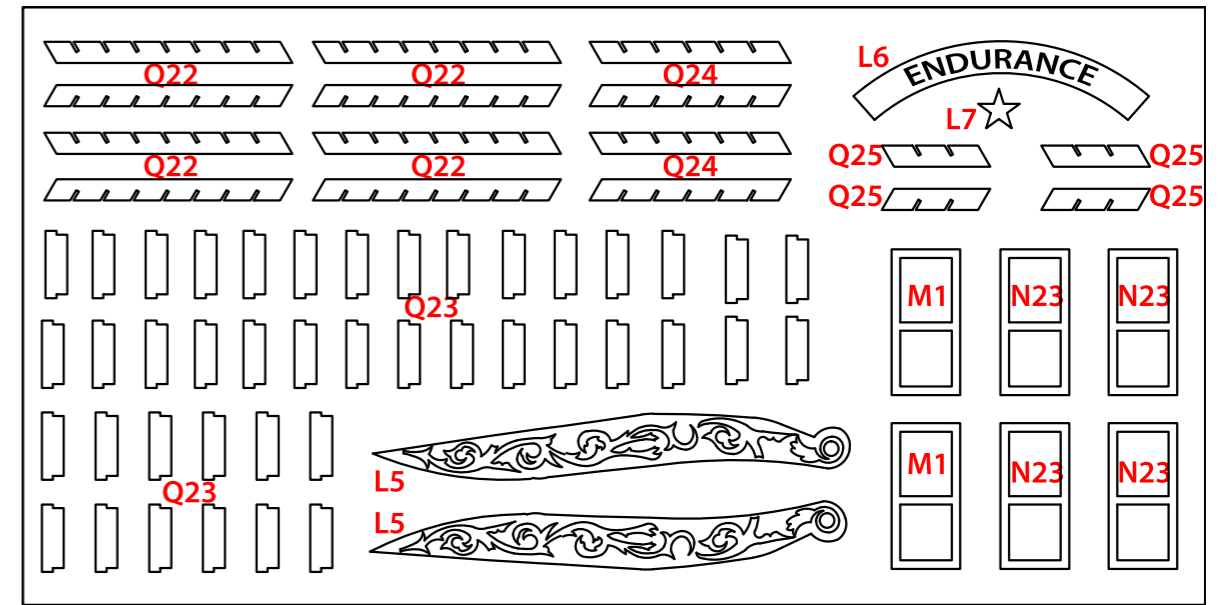

12008-10

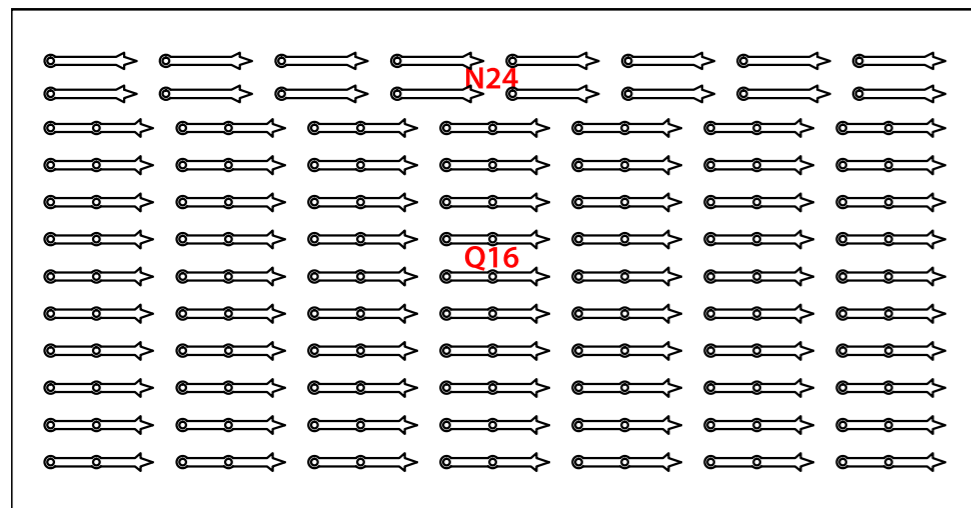

12008-9

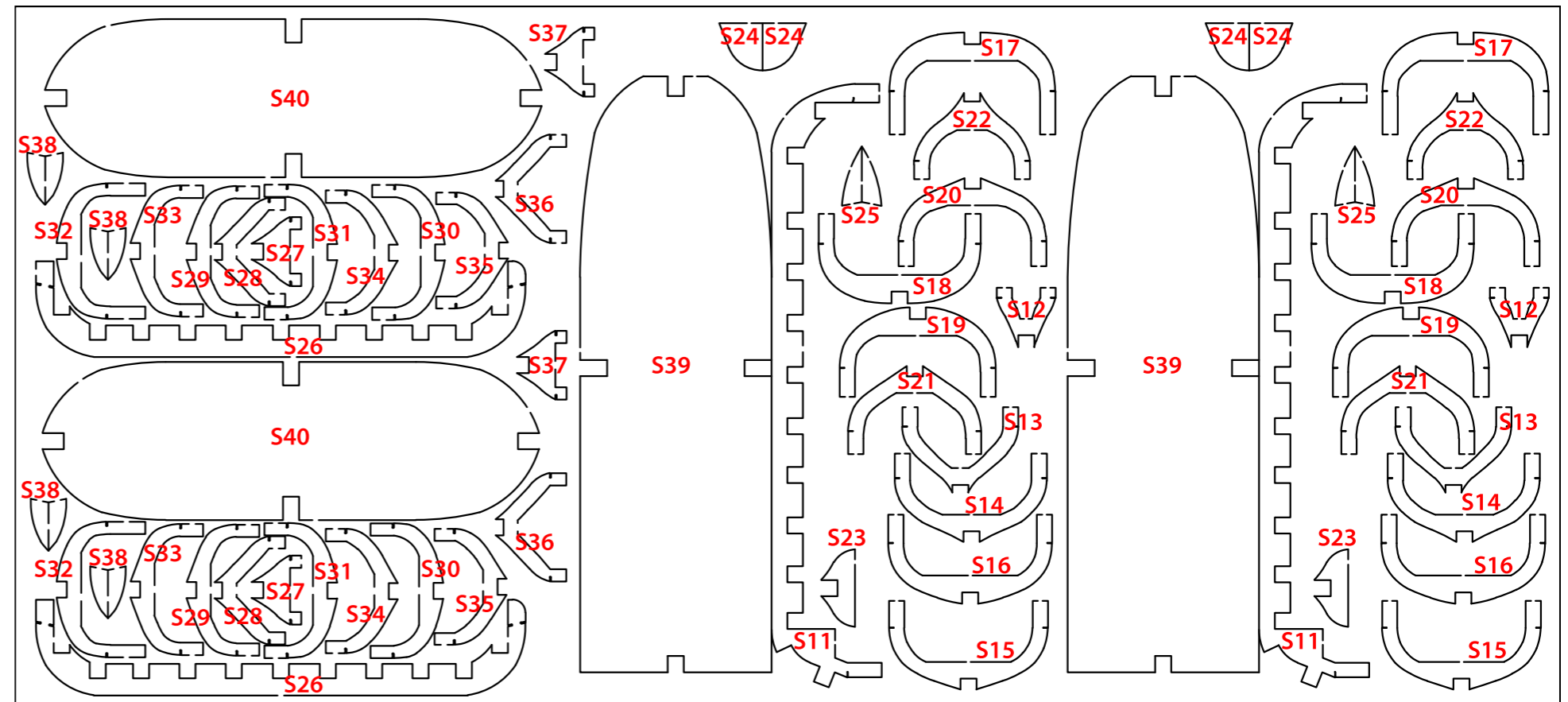

12008-7

Endurance PL-01

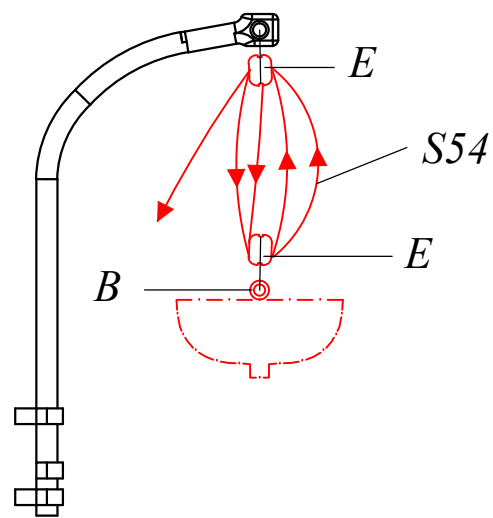
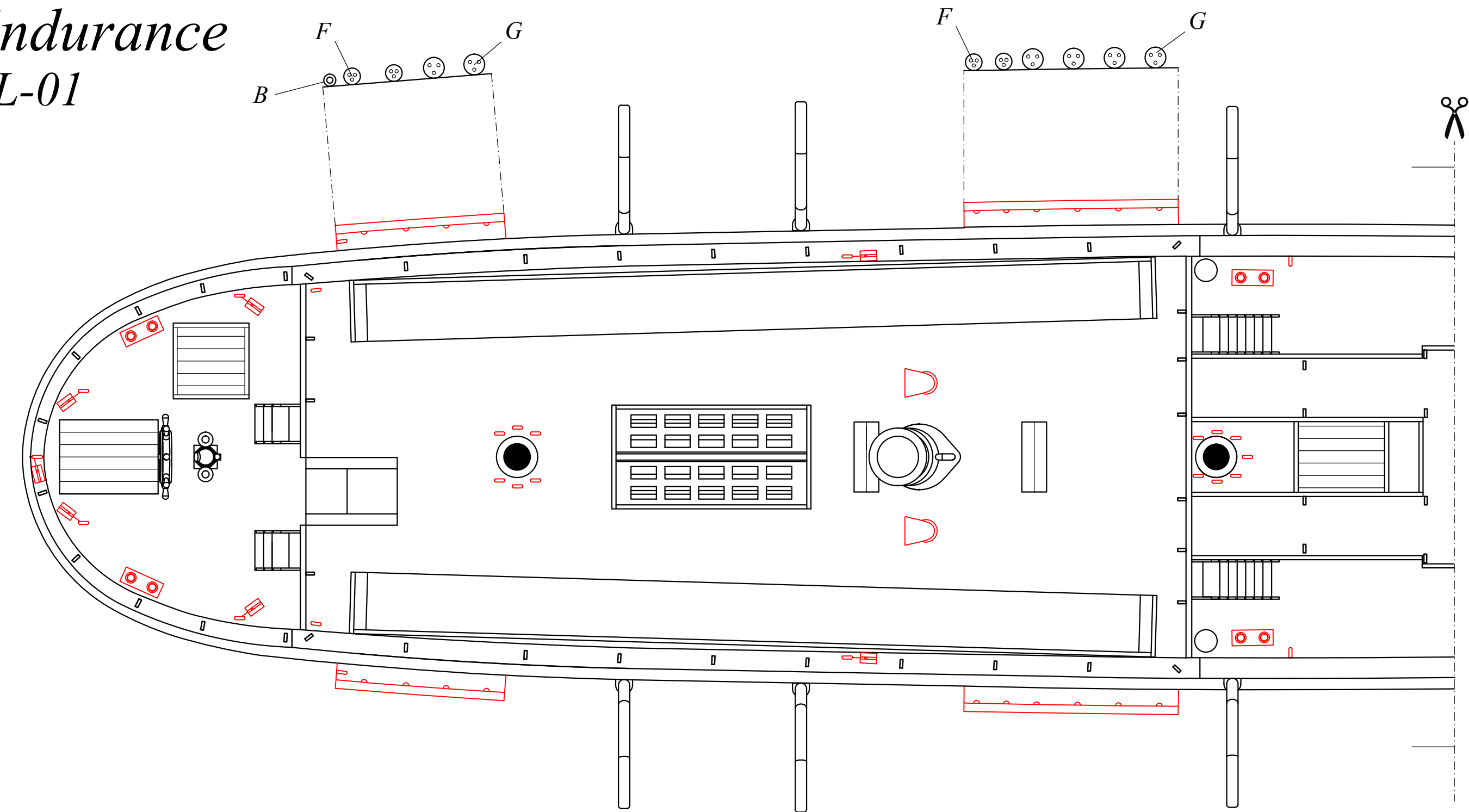

- S54
- S8 - $\phi 1 \times 22 \text{mm}$
x4
- S10 - $1 \times 3 \times 6 \text{mm}$
x4
- S9 - $1 \times 4 \times 13 \text{mm}$
x2

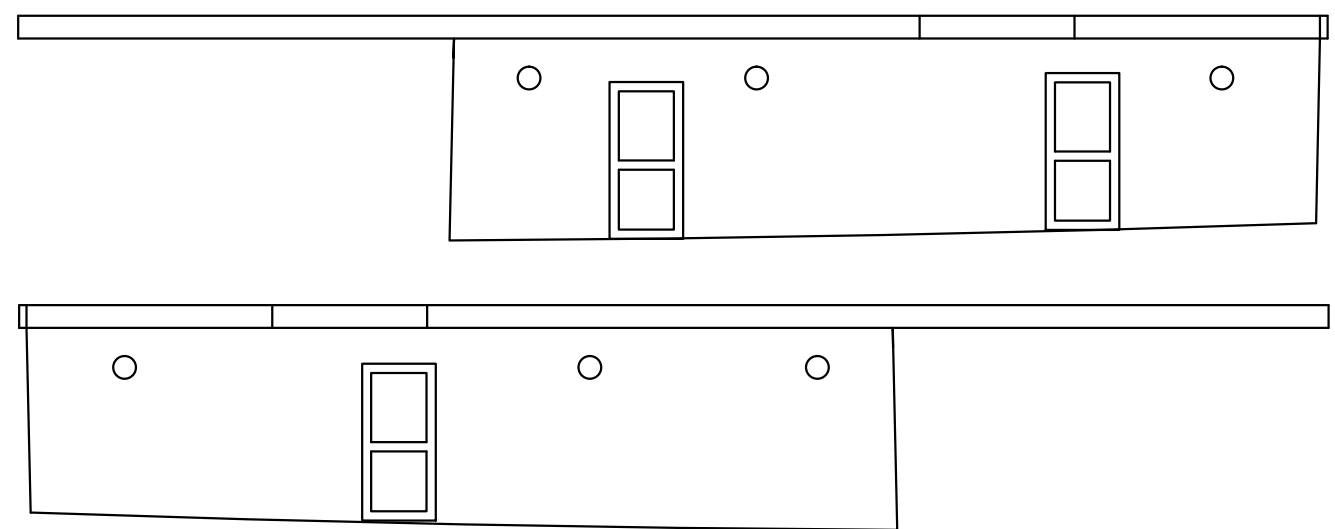

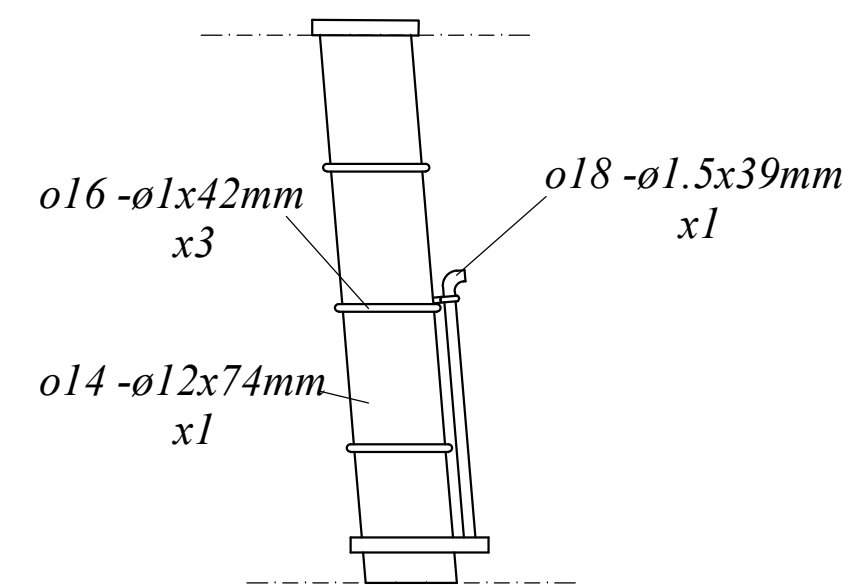
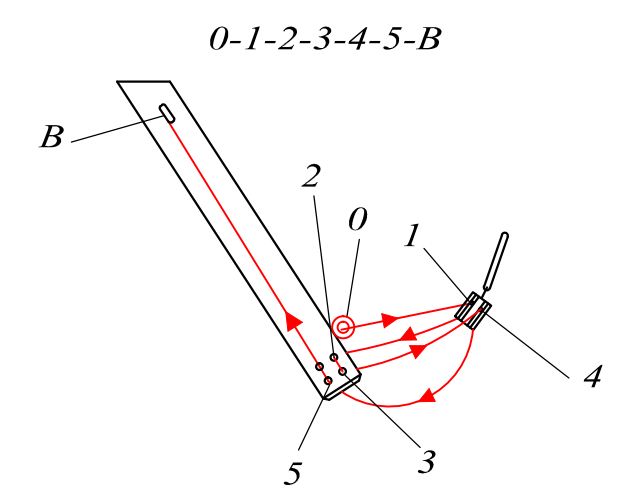
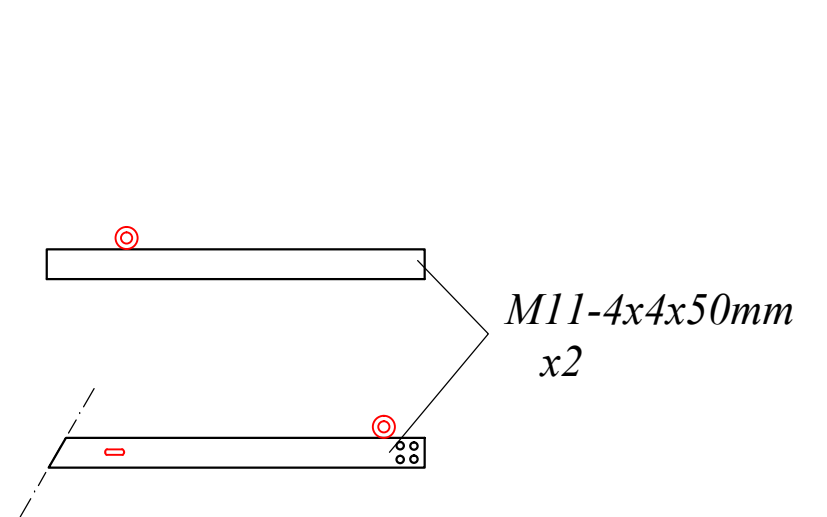
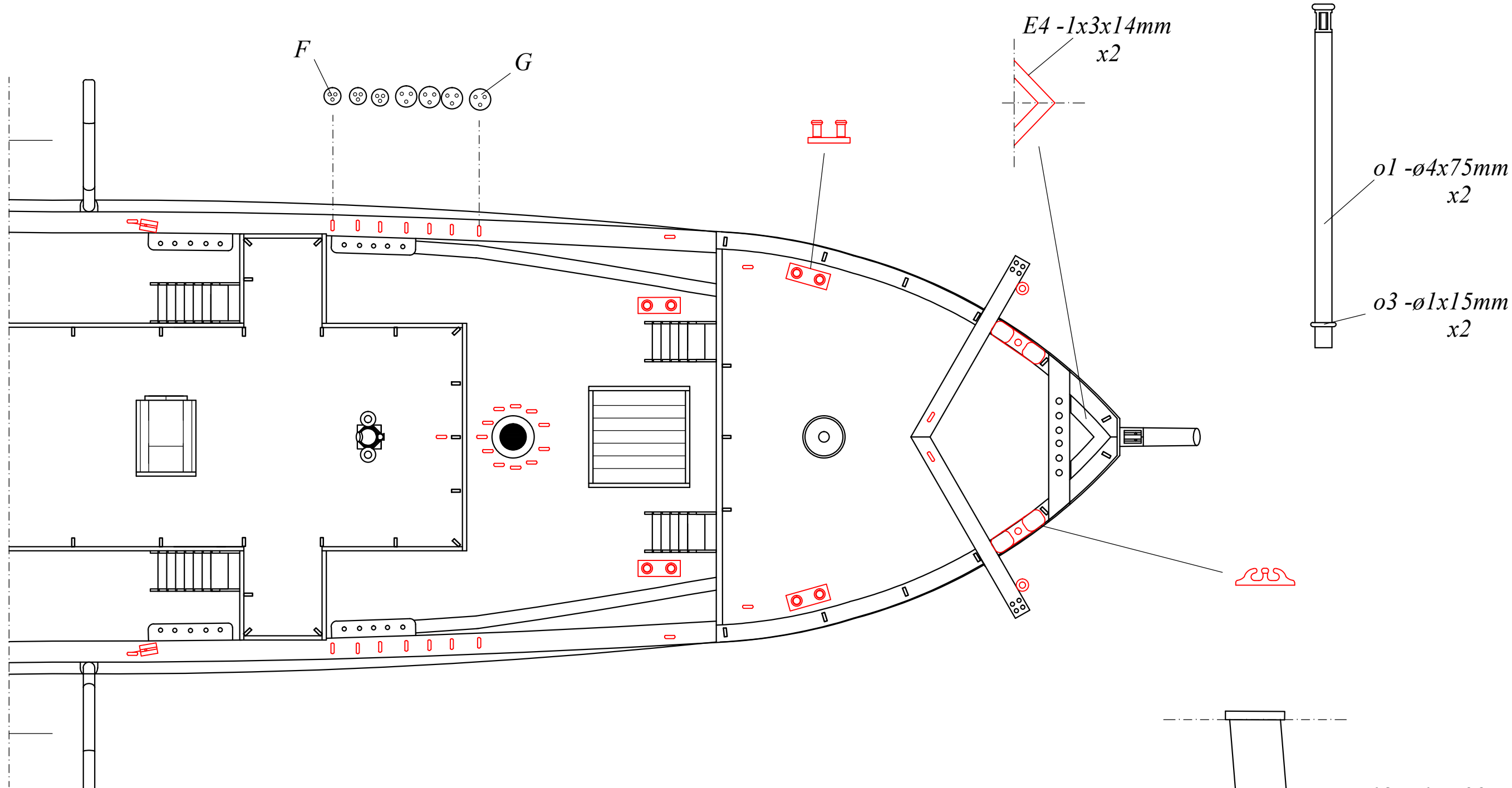





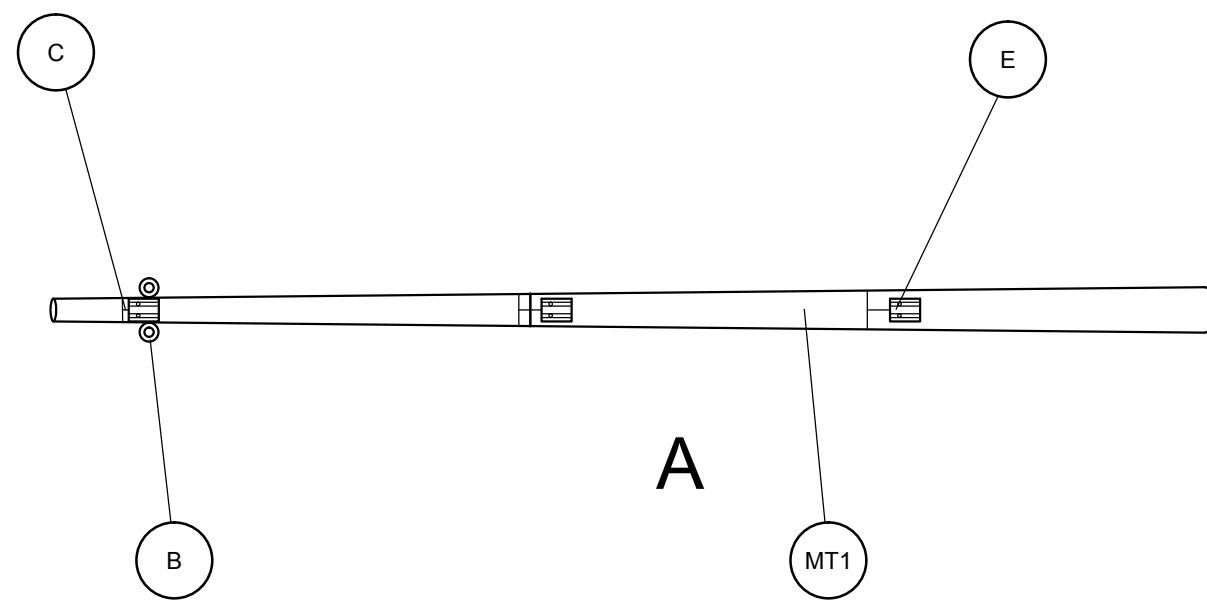
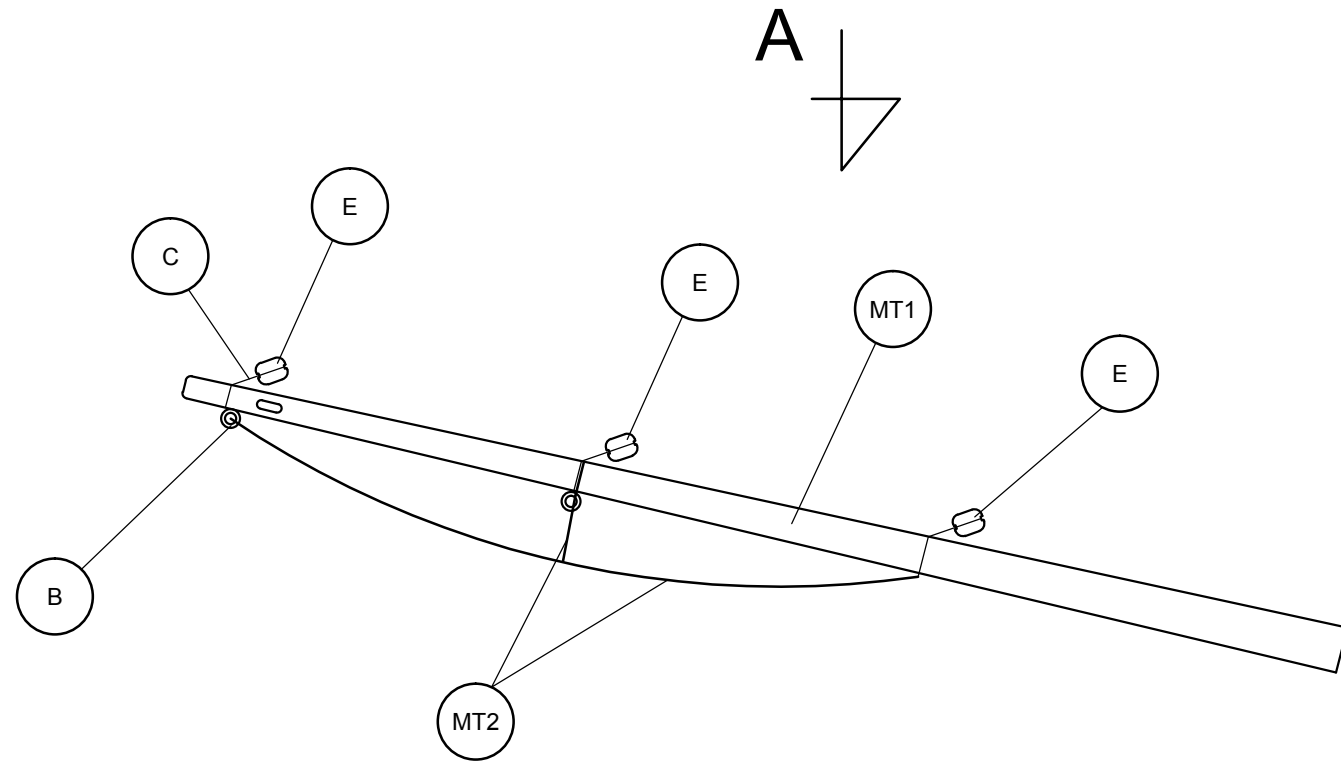
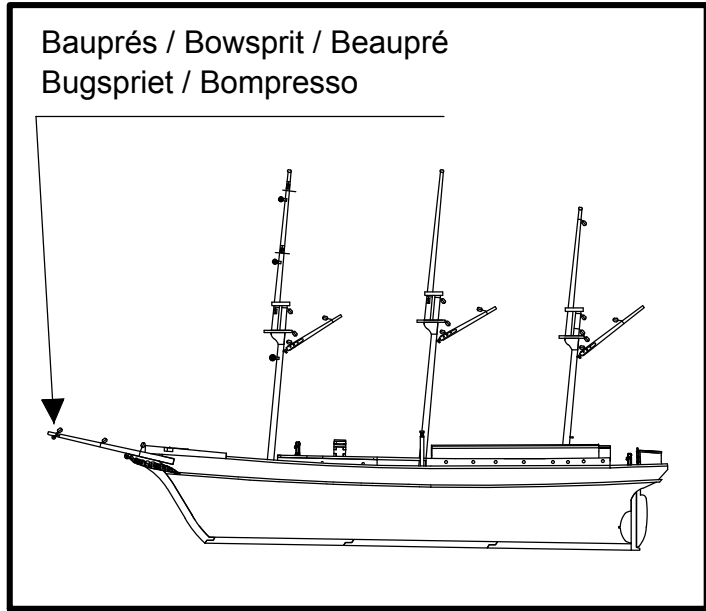

Scale 1/1

Endurance



Scale 1/1

MT1	∅6x157	Tilo / Lime wood / Tilleul / Linde / Tiglio
MT2	∅0,50x200	Hilo marrón / Brown thread / Fil brun / braunes Baumwollfaden / Filo marrone
B	15	Latón / Brass / Laiton / Messing / Ottone
C	∅0,15x100	Hilo crudo / Raw thread / Fil brut / Rohes Baumwollfaden / Filo crudo
E	4	Composite / Composite / Composite / Composite / Composite

<p>B </p> <p><i>Cáncamo</i> <i>Eyebolts</i> <i>Piton à oeil</i> <i>Tragöse</i> <i>Cavilie di ferro ad anello</i></p>	<p>D </p> <p><i>Moton</i> <i>Blocks</i> <i>Poulie</i> <i>Blockrolle</i> <i>Bozzello</i></p>	<p>E </p> <p><i>Cuadernal</i> <i>Double blocks</i> <i>Poulie double</i> <i>Block</i> <i>Costale</i></p>	<p>F-G </p> <p><i>Vigota</i> <i>Dead eyes</i> <i>Cap de mouton</i> <i>Jungferblock</i> <i>Bigotta</i></p>	<p>H </p> <p><i>Anilla</i> <i>Rings</i> <i>Oeil</i> <i>Öse</i> <i>Anello</i></p>	<p>J </p> <p><i>Cabilla</i> <i>Belaying Pins</i> <i>Cheville</i> <i>Rundeisen</i> <i>Caviglia</i></p>
--	---	---	---	--	---

Endurance

Palo trinquete / Fore mast / Mât de misaine
Albero trinchetto / Fockmast

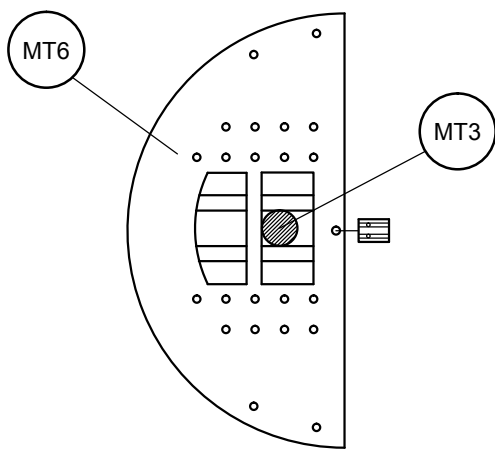
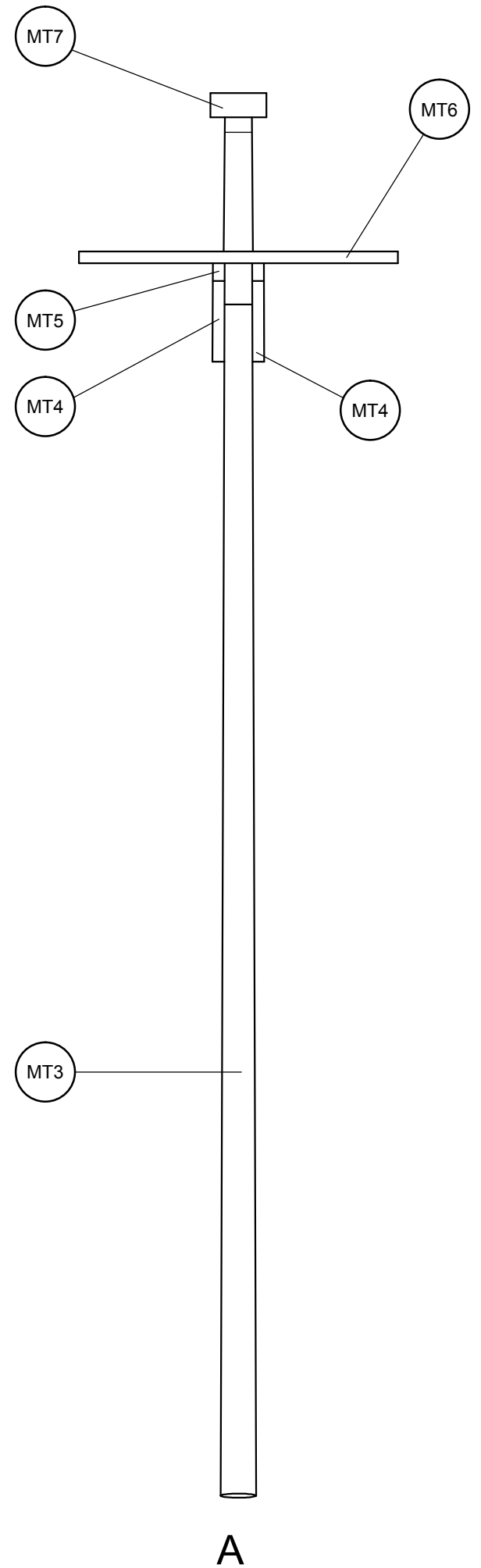
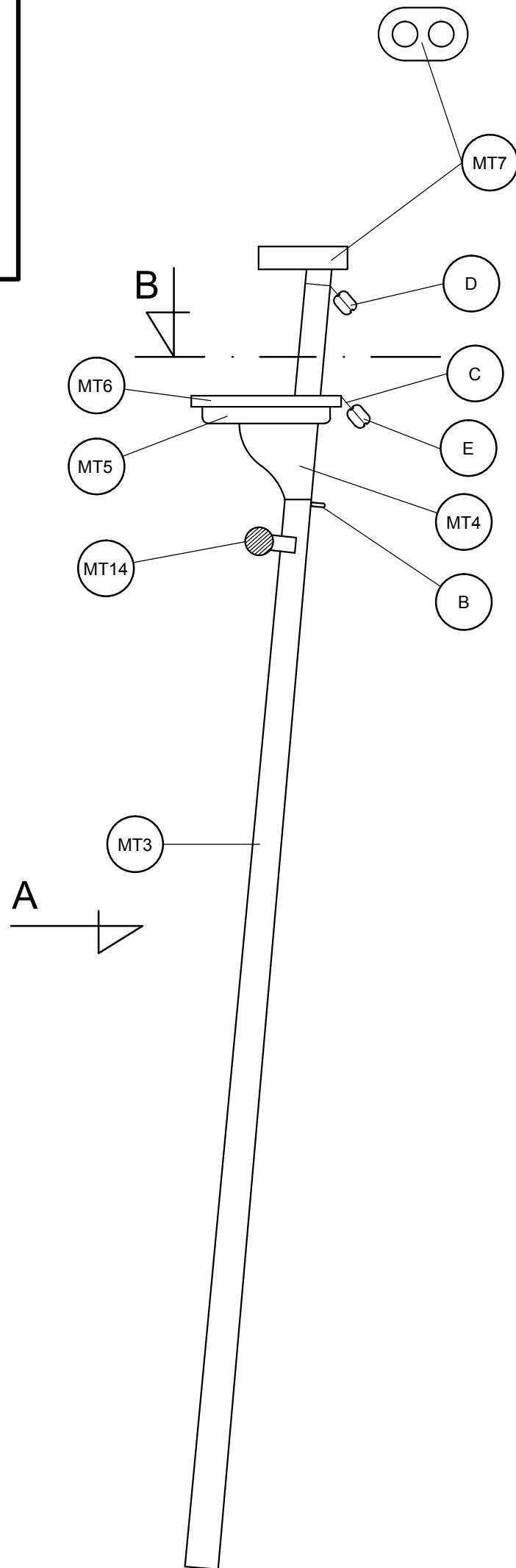
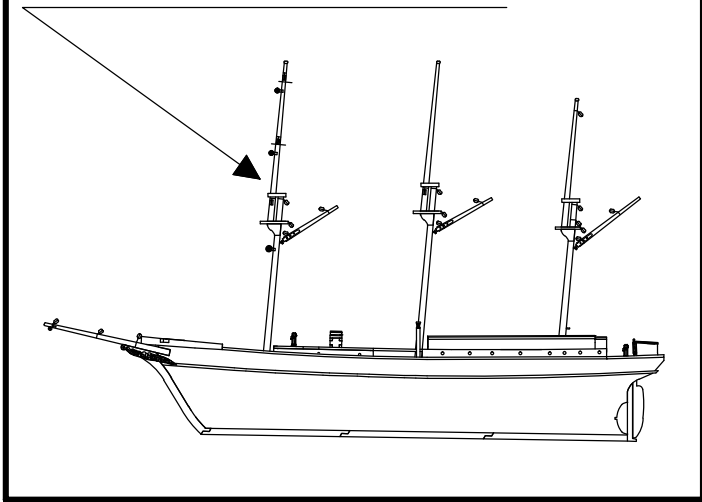

B

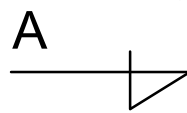

A

MT3	ø6x239	Tilo / Lime wood / Tilleul / Linde / Tiglio	B	15	Latón / Brass / Laiton / Messing / Ottone
MT4	Precortado / Precut / Prédécoupé / Vorgeschnitten/ Pretagliato	Tablero / Plywood / Planche / Sperrholz / Tavola	C	ø0,15x100	Hilo crudo / Raw thread / Fil brut / Rohes Baumwollfaden / Filo crudo
MT5	2x3x23	Tilo / Lime wood / Tilleul / Linde / Tiglio	D	4	Composite / Composite / Composite / Composite / Composite
MT6	Precortado / Precut / Prédécoupé / Vorgeschnitten/ Pretagliato	Tablero / Plywood / Planche / Sperrholz / Tavola	E	4	Composite / Composite / Composite / Composite / Composite
MT7	Precortado / Precut / Prédécoupé / Vorgeschnitten/ Pretagliato	Tablero / Plywood / Planche / Sperrholz / Tavola			

Endurance

Palo trinquete / Fore mast / Mât de misaine
 Albero trinchetto / Fockmast

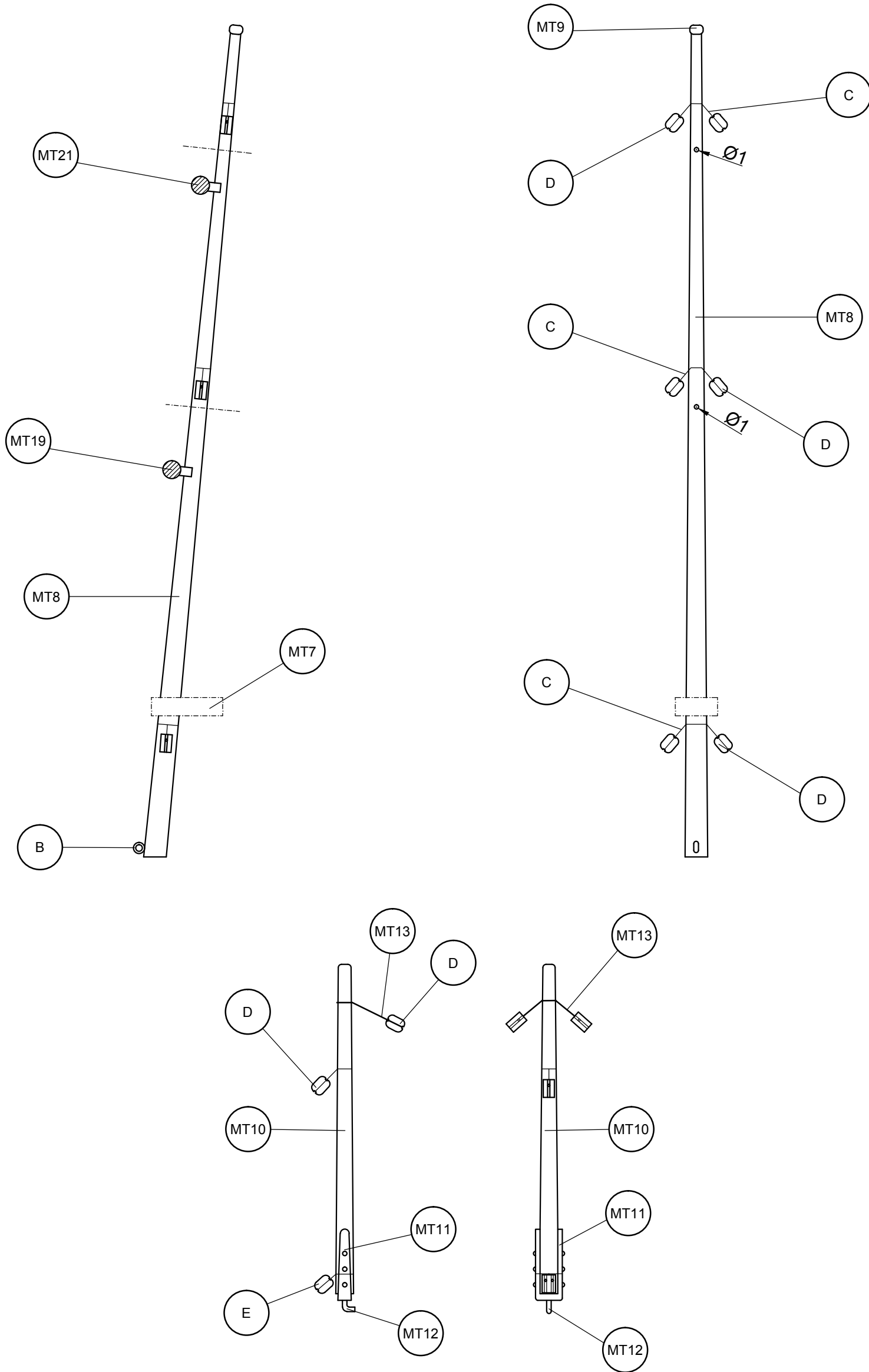

Scale 1/1

MT8	Ø5x186	Tilo / Lime wood / Tilleul / Linde / Tiglio	MT13	ø0,50x100	Hilo marrón / Brown thread / Fil brun /braunes Baumwollfaden / Filo marrone
MT9	ø3	Cristal / Glass / Verre / Glas / Cristallo	B	15	Latón / Brass / Laiton / Messing / Ottone
MT10	Ø4x74	Tilo / Lime wood / Tilleul / Linde / Tiglio	C	ø0,15x100	Hilo crudo / Raw thread / Fil brut / Rohes Baumwollfaden / Filo crudo
MT11	Preformado / Preformed/ Préformé / Vorgeformt / Preformato	Metal / Metal / Metal / Metall / Metallo	D	4	Composite / Composite / Composite / Composite / Composite
MT12	ø1x10	Latón / Brass / Laiton / Messing / Ottone	E	4	Composite / Composite / Composite / Composite / Composite

Endurance

Palo trinquete / Fore mast / Mât de misaine
 Albero trinchetto / Fockmast

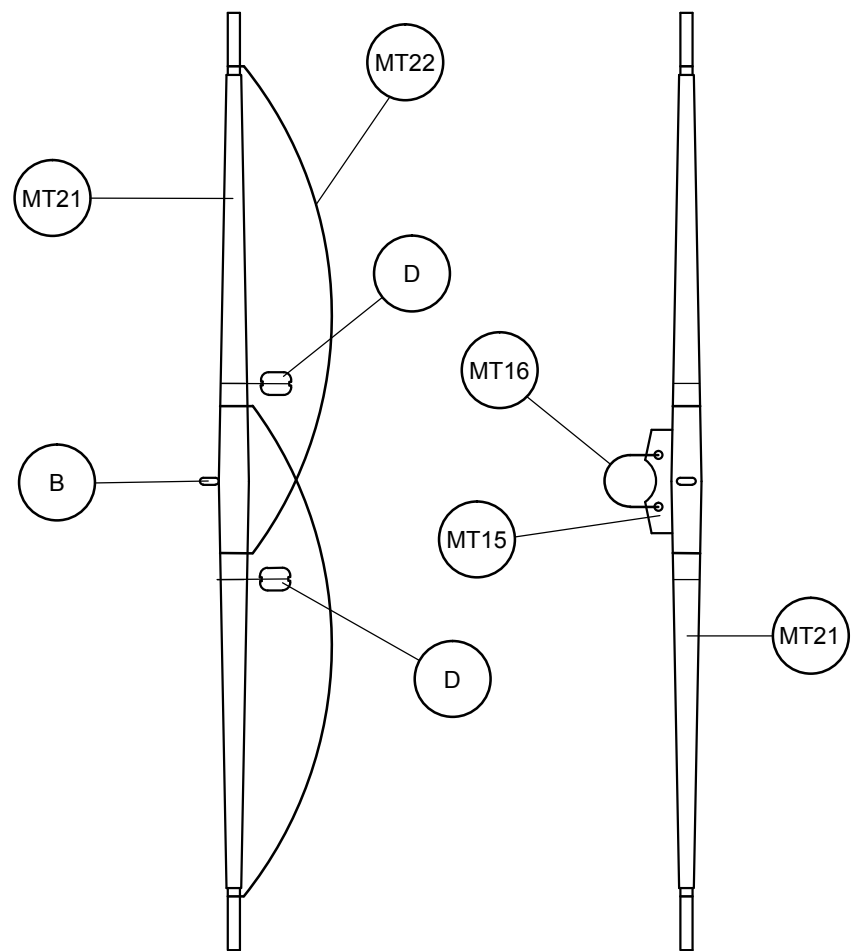
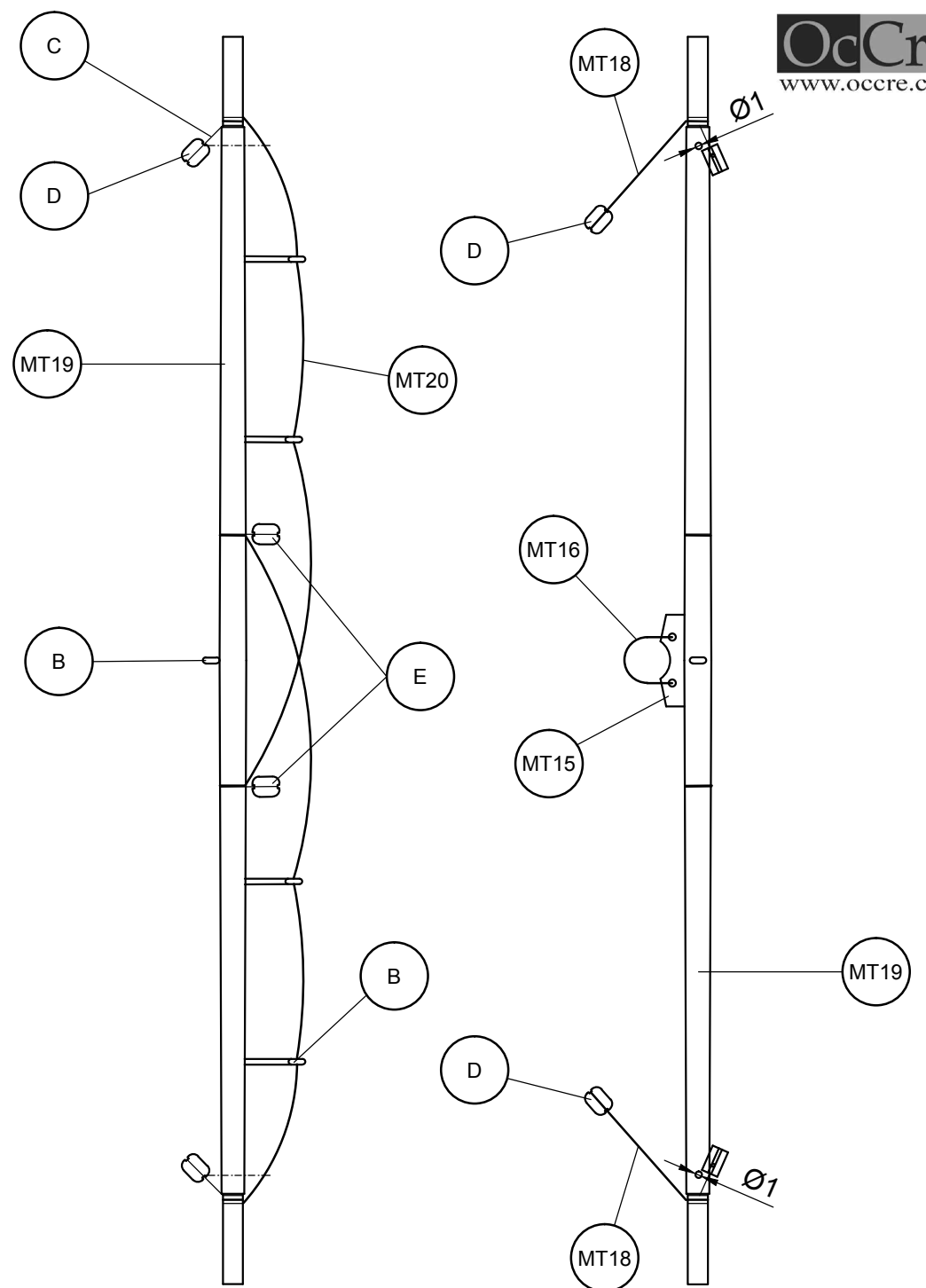
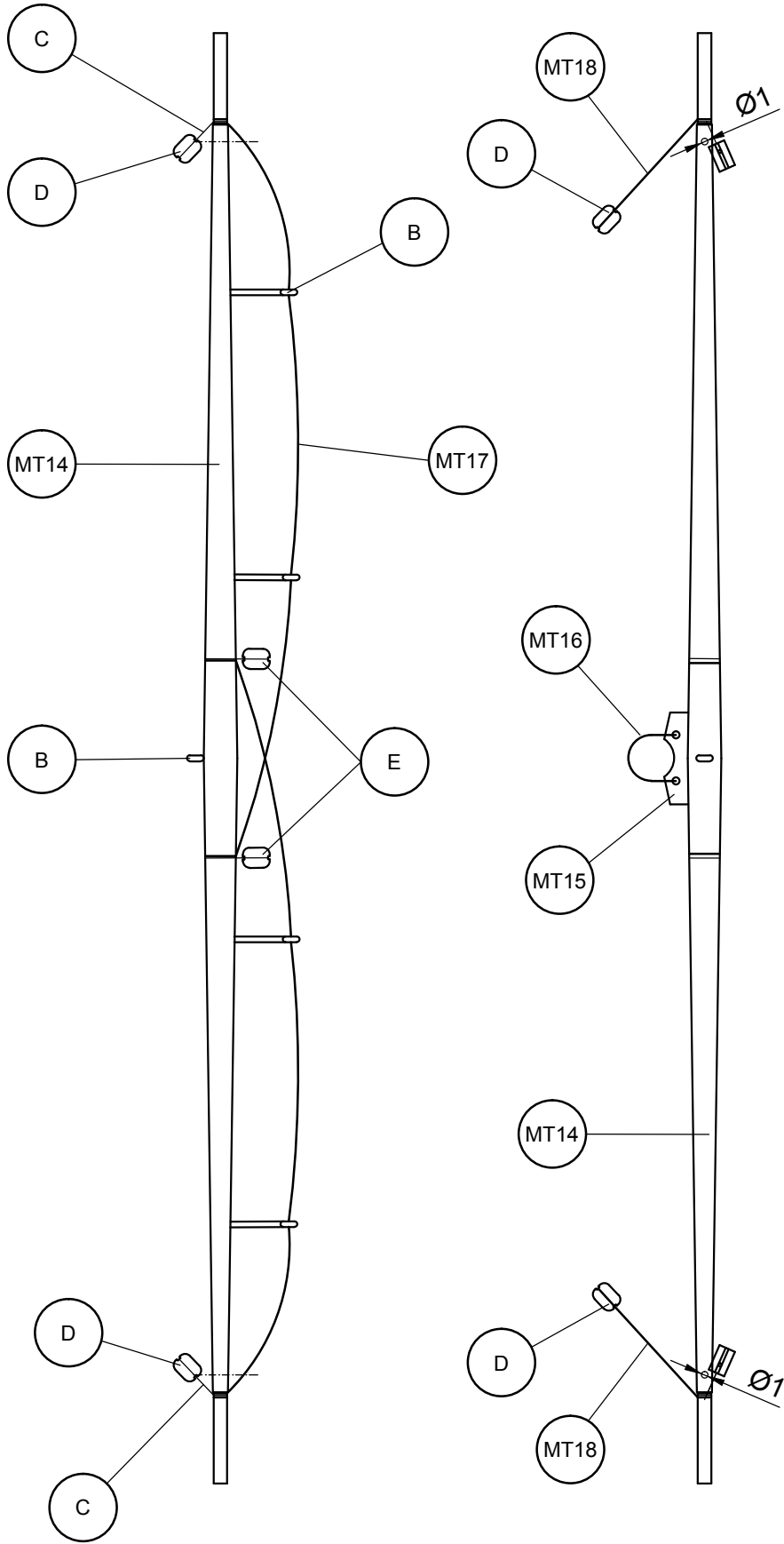

MT14	Ø5x216	Tilo / Lime wood / Tilleul / Linde / Tiglio	MT21	Ø4x124	Tilo / Lime wood / Tilleul / Linde / Tiglio
MT15	Precortado / Precut / Prédécoupé / Vorgeschnitten/ Pretagliato	Tablero / Plywood / Planche / Sperrholz / Tavola	MT22	Ø0,50x150	Hilo marrón / Brown thread / Fil brun /braunes Baumwollfaden / Filo marrone
MT16	Ø0,50x100	Hilo marrón / Brown thread / Fil brun /braunes Baumwollfaden / Filo marrone	B	15	Latón / Brass / Laiton / Messing / Ottone
MT17	Ø0,50x200	Hilo marrón / Brown thread / Fil brun /braunes Baumwollfaden / Filo marrone	C	Ø0,15x100	Hilo crudo / Raw thread / Fil brut / Rohes Baumwollfaden / Filo crudo
MT18	Ø0,50x125	Hilo marrón / Brown thread / Fil brun /braunes Baumwollfaden / Filo marrone	D	4	Composite / Composite / Composite / Composite / Composite
MT19	Ø4x186	Tilo / Lime wood / Tilleul / Linde / Tiglio	E	4	Composite / Composite / Composite / Composite / Composite
MT20	Ø0,50x175	Hilo marrón / Brown thread / Fil brun /braunes Baumwollfaden / Filo marrone			

Endurance

Palo mayor / Main mast / Grand mât
Hauptmast / Albero maestro

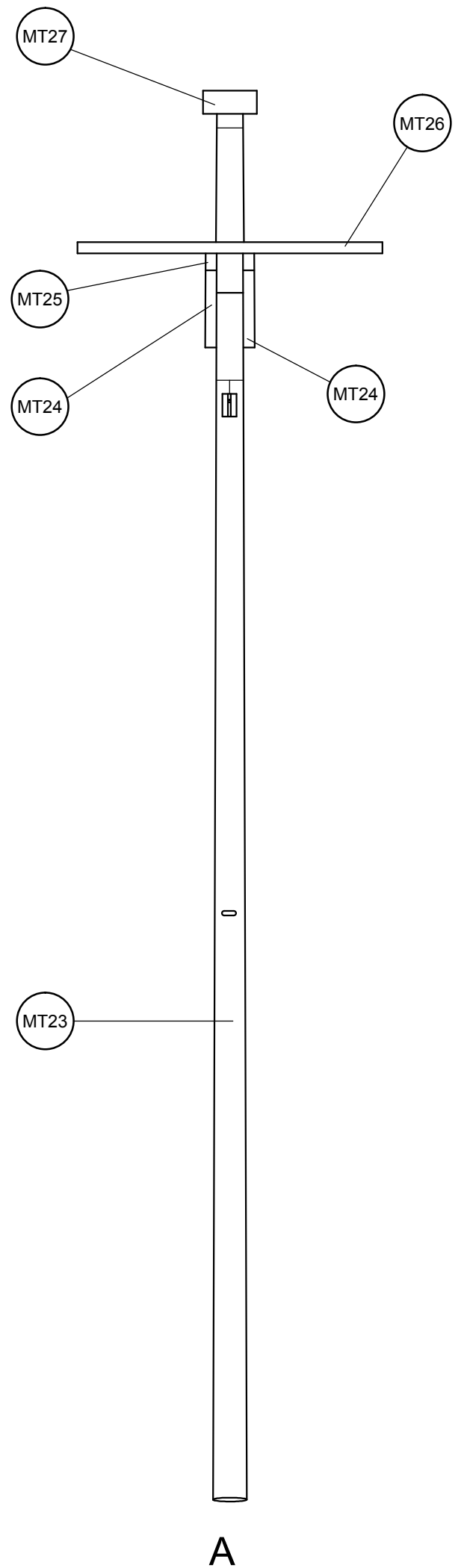
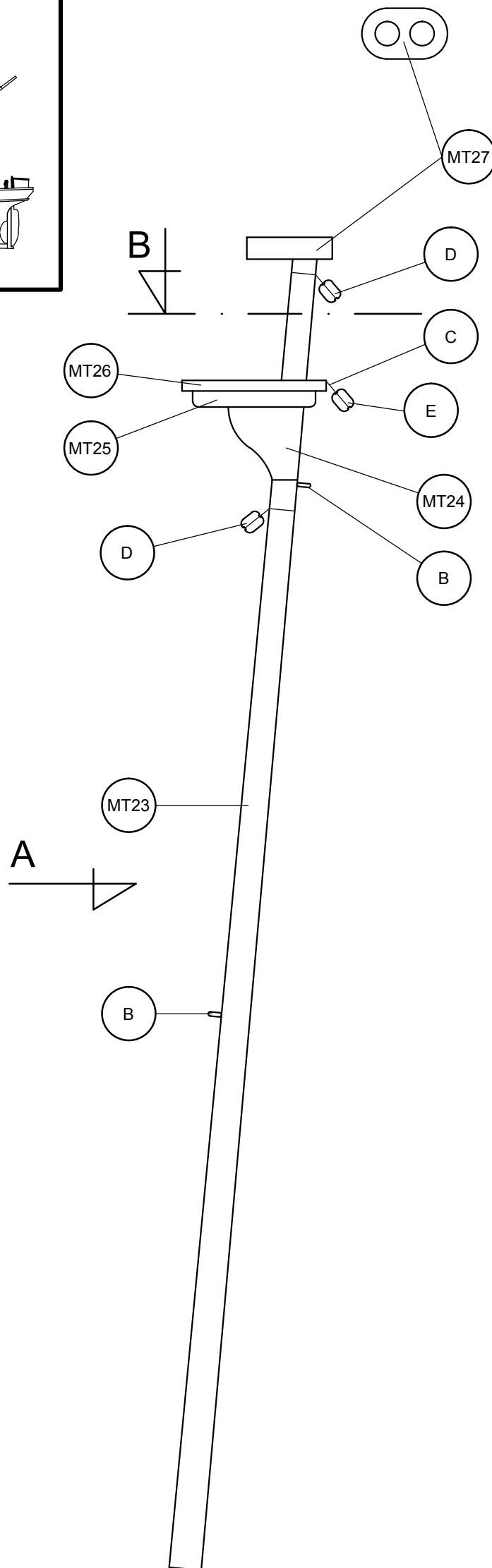
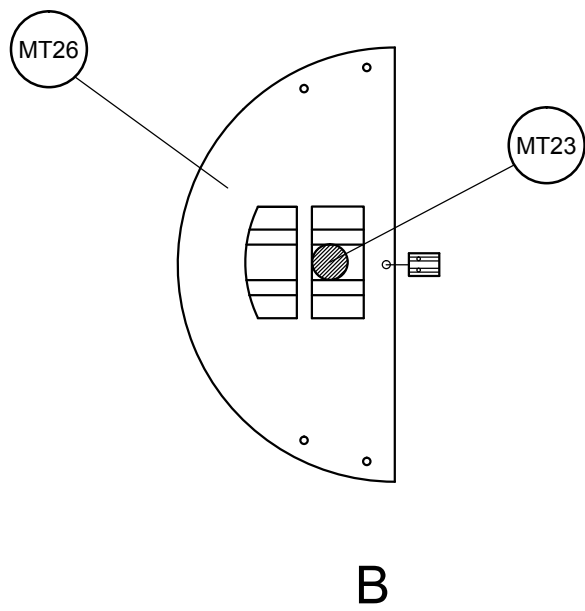
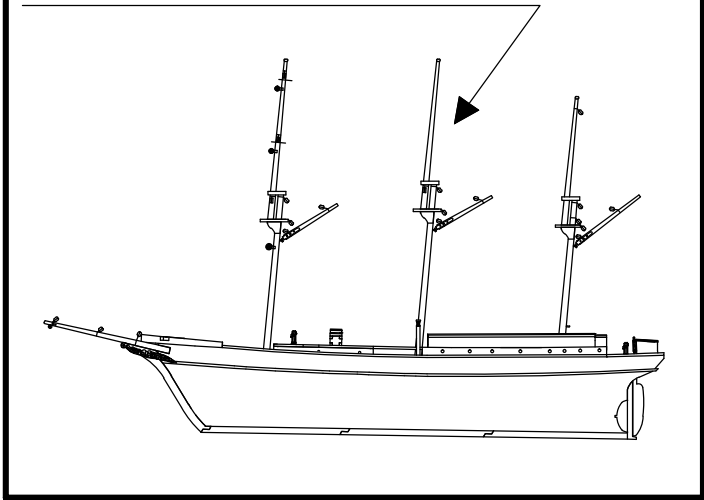

Scale 1/1

MT23	ø6x251	Tilo / Lime wood / Tilleul / Linde / Tiglio	B	15	Latón / Brass / Laiton / Messing / Ottone
MT24	Precortado / Precut / Prédécoupé / Vorgeschnitten/ Pretagliato	Tablero / Plywood / Planche / Sperrholz / Tavola	C	ø0,15x100	Hilo crudo / Raw thread / Fil brut / Rohes Baumwollfaden / Filo crudo
MT25	2x3x23	Tilo / Lime wood / Tilleul / Linde / Tiglio	D	4	Composite / Composite / Composite / Composite / Composite
MT26	Precortado / Precut / Prédécoupé / Vorgeschnitten/ Pretagliato	Tablero / Plywood / Planche / Sperrholz / Tavola	E	4	Composite / Composite / Composite / Composite / Composite
MT27	Precortado / Precut / Prédécoupé / Vorgeschnitten/ Pretagliato	Tablero / Plywood / Planche / Sperrholz / Tavola			

Endurance

Palo mayor / Main mast / Grand mât
Hauptmast / Albero maestro

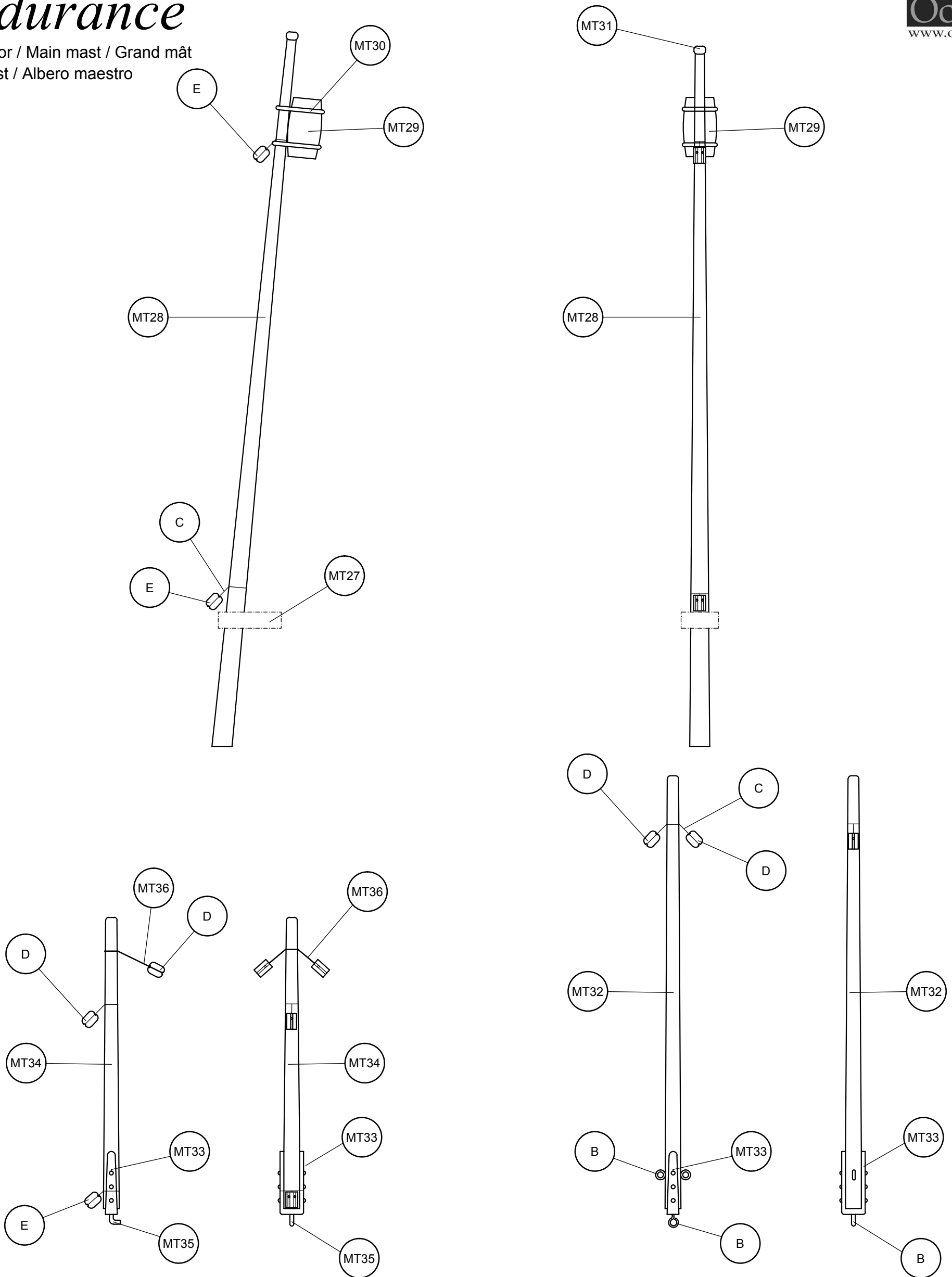

Scale 1/1

MT28	ø5x181	Tilo / Lime wood / Tilleul / Linde / Tiglio	MT35	ø1x10	Latón / Brass / Laiton / Messing / Ottone
MT29	Preformado / Prefomed/ Préformé / Vorgeformt / Preformato	Madera / Wood / Bois / Holz / Legno	MT36	ø0,50x100	Hilo marrón / Brown thread / Fil brun /braunes Baumwollfaden / Filo marrone
MT30	ø1x80	Latón / Brass / Laiton / Messing / Ottone	B	15	Latón / Brass / Laiton / Messing / Ottone
MT31	ø3	Cristal / Glass / Verre / Glas / Cristallo	C	ø0,15x100	Hilo crudo / Raw thread / Fil brut / Rohes Baumwollfaden / Filo crudo
MT32	ø4x110	Tilo / Lime wood / Tilleul / Linde / Tiglio	D	4	Composite / Composite / Composite / Composite / Composite
MT33	Preformado / Prefomed/ Préformé / Vorgeformt / Preformato	Metal / Metal / Metal / Metall / Metallo	E	4	Composite / Composite / Composite / Composite / Composite
MT34	ø4x74	Tilo / Lime wood / Tilleul / Linde / Tiglio			

Endurance

Palo mesana / Mizze mast / Mât d'artimon
Besanmast / Albero mezzana

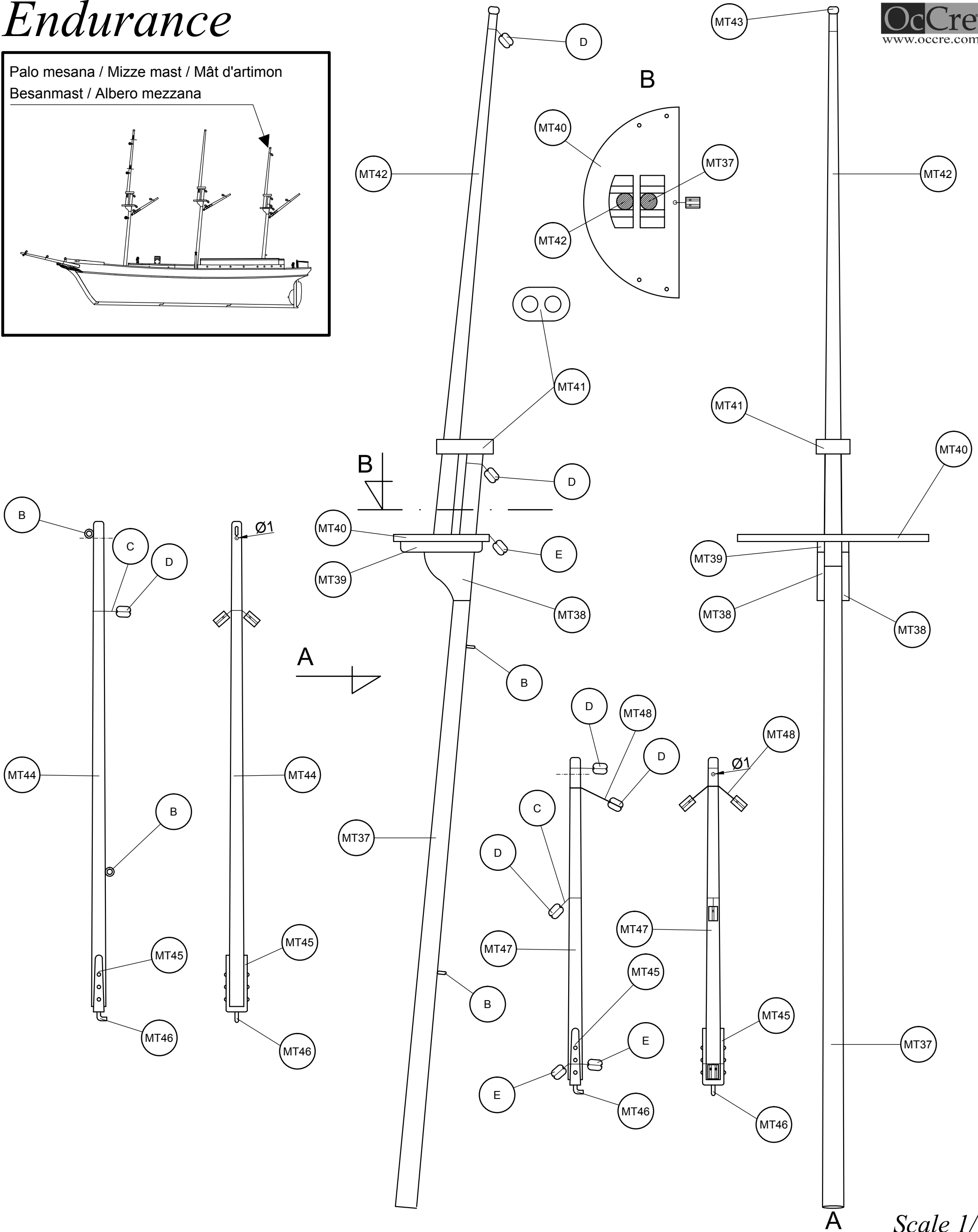
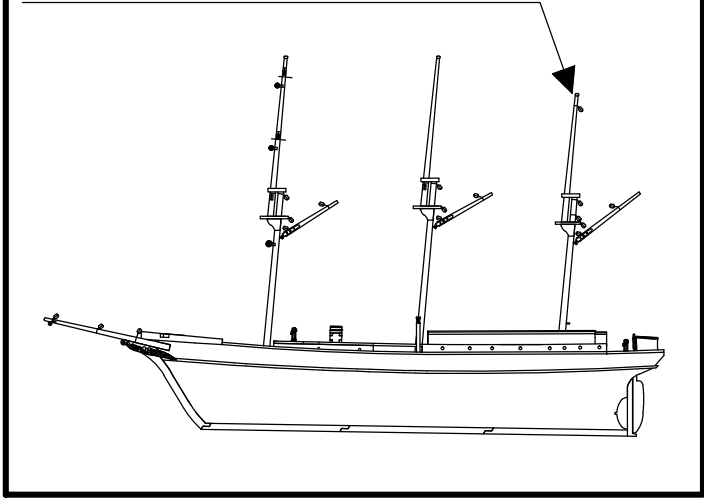

Scale 1/1

MT37	∅6x217	Tilo / Lime wood / Tilleul / Linde / Tiglio	MT45	Preformado / Prefomed/ Préformé / Vorgeformt / Preformato	Metal / Metal / Metal / Metall / Metallo
MT38	Precortado / Precut / Prédécoupé / Vorgeschnitten/ Pretagliato	Tablero / Plywood / Planche / Sperrholz / Tavola	MT46	∅1x10	Latón / Brass / Laiton / Messing / Ottone
MT39	2x3x23	Tilo / Lime wood / Tilleul / Linde / Tiglio	MT47	∅4x91	Tilo / Lime wood / Tilleul / Linde / Tiglio
MT40	Precortado / Precut / Prédécoupé / Vorgeschnitten/ Pretagliato	Tablero / Plywood / Planche / Sperrholz / Tavola	MT48	∅0,50x100	Hilo marrón / Brown thread / Fil brun/braunes Baumwollfaden / Filo marrone
MT41	Precortado / Precut / Prédécoupé / Vorgeschnitten/ Pretagliato	Tablero / Plywood / Planche / Sperrholz / Tavola	B	15	Latón / Brass / Laiton / Messing / Ottone
MT42	∅5x156	Tilo / Lime wood / Tilleul / Linde / Tiglio	C	∅0,15x100	Hilo crudo / Raw thread / Fil brut / Rohes Baumwollfaden / Filo crudo
MT43	∅3	Cristal / Glass / Verre / Glas / Cristallo	D	4	Composite / Composite / Composite / Composite / Composite
MT44	∅4x137	Tilo / Lime wood / Tilleul / Linde / Tiglio	E	4	Composite / Composite / Composite / Composite / Composite

Endurance

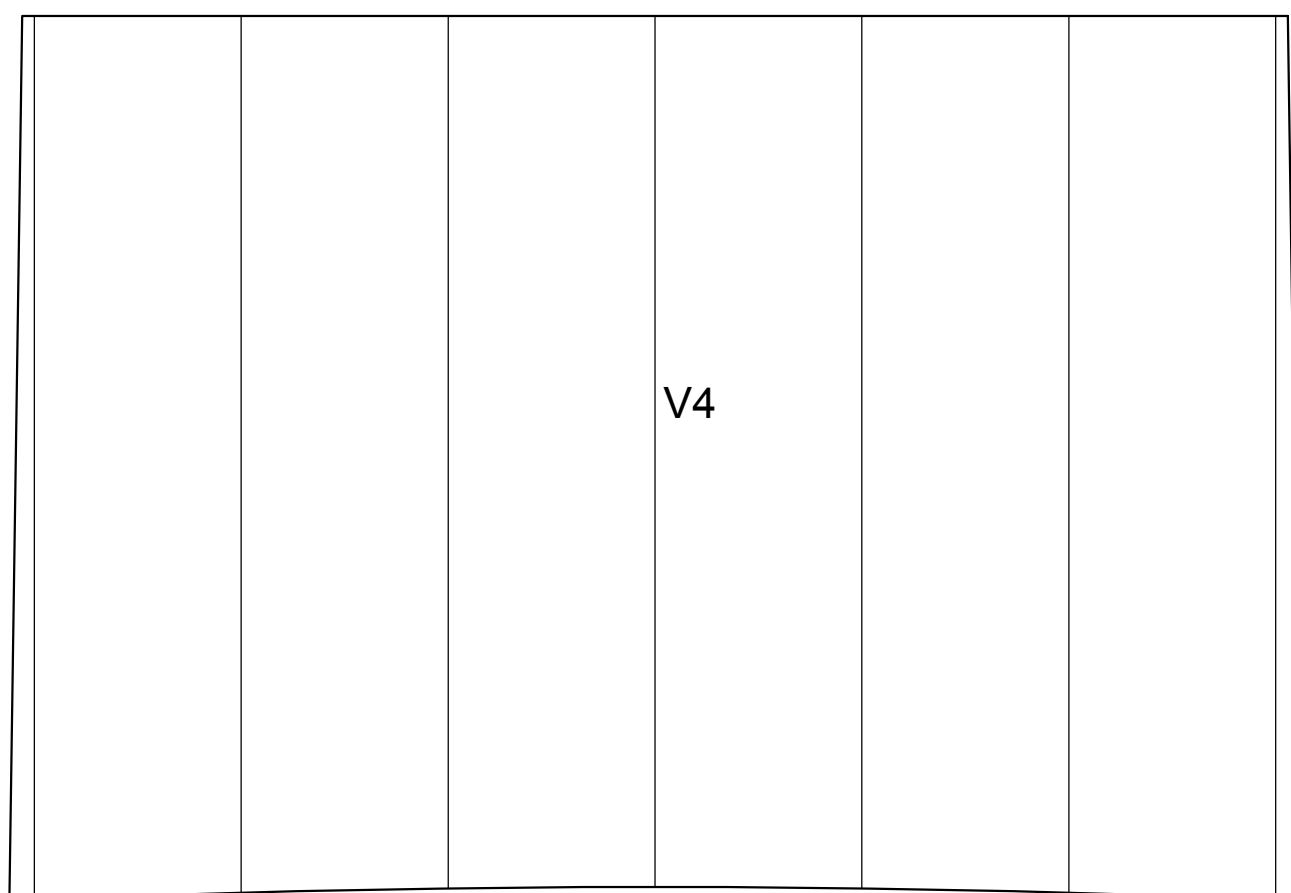
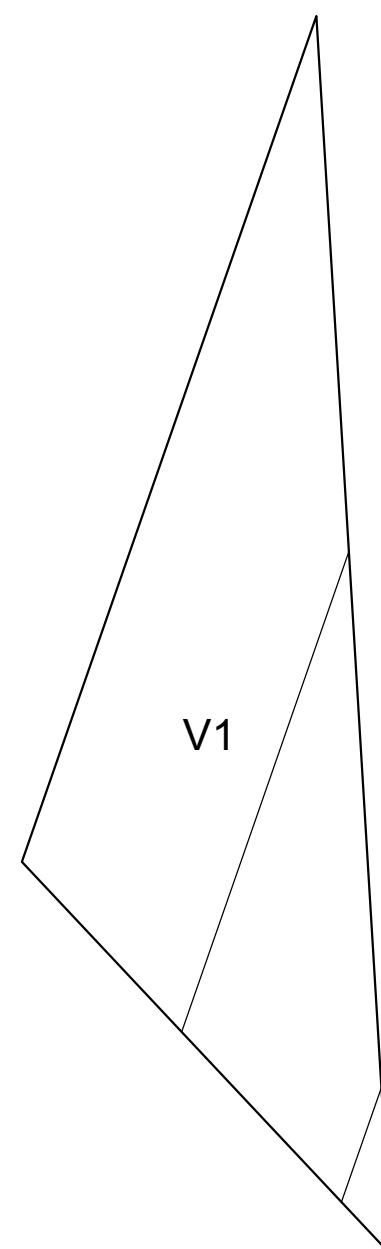
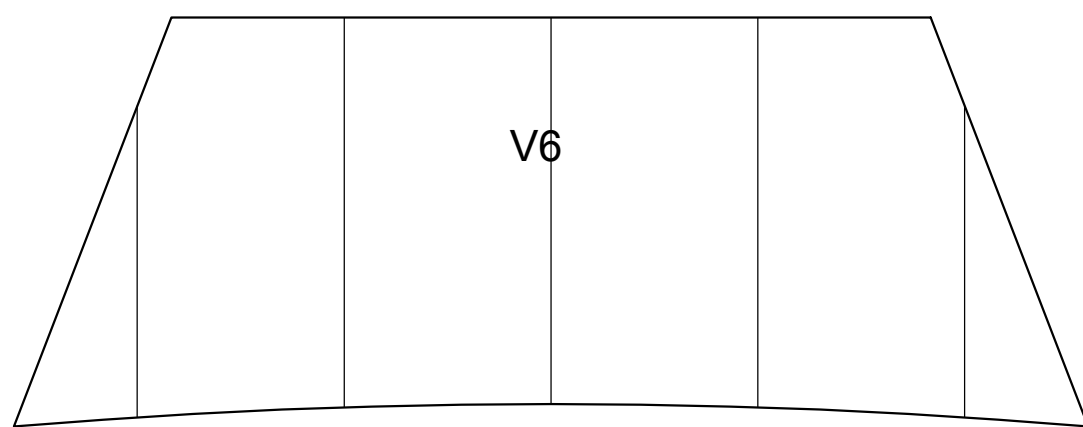
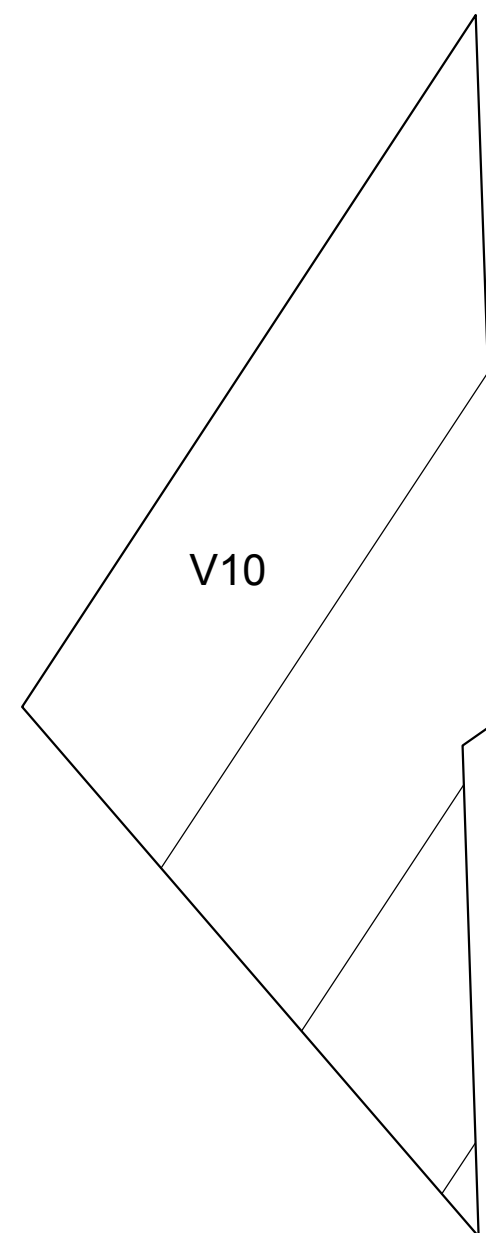
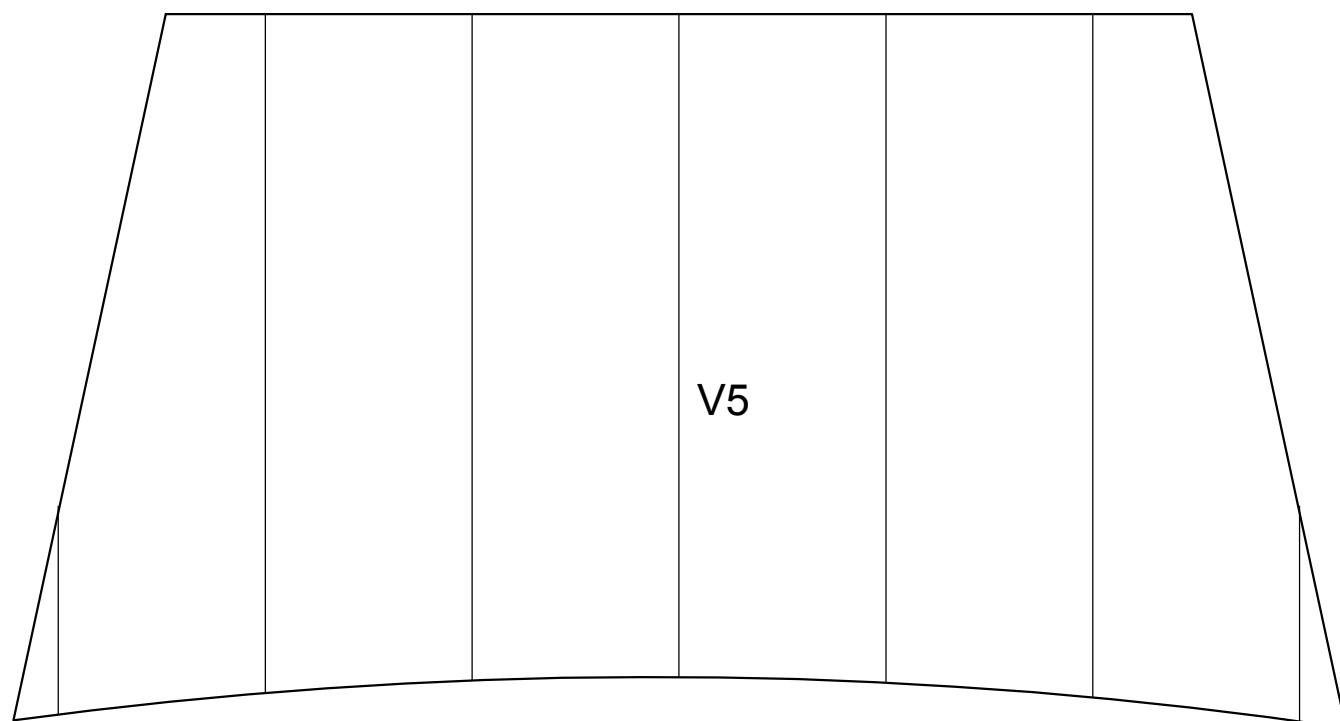

Endurance

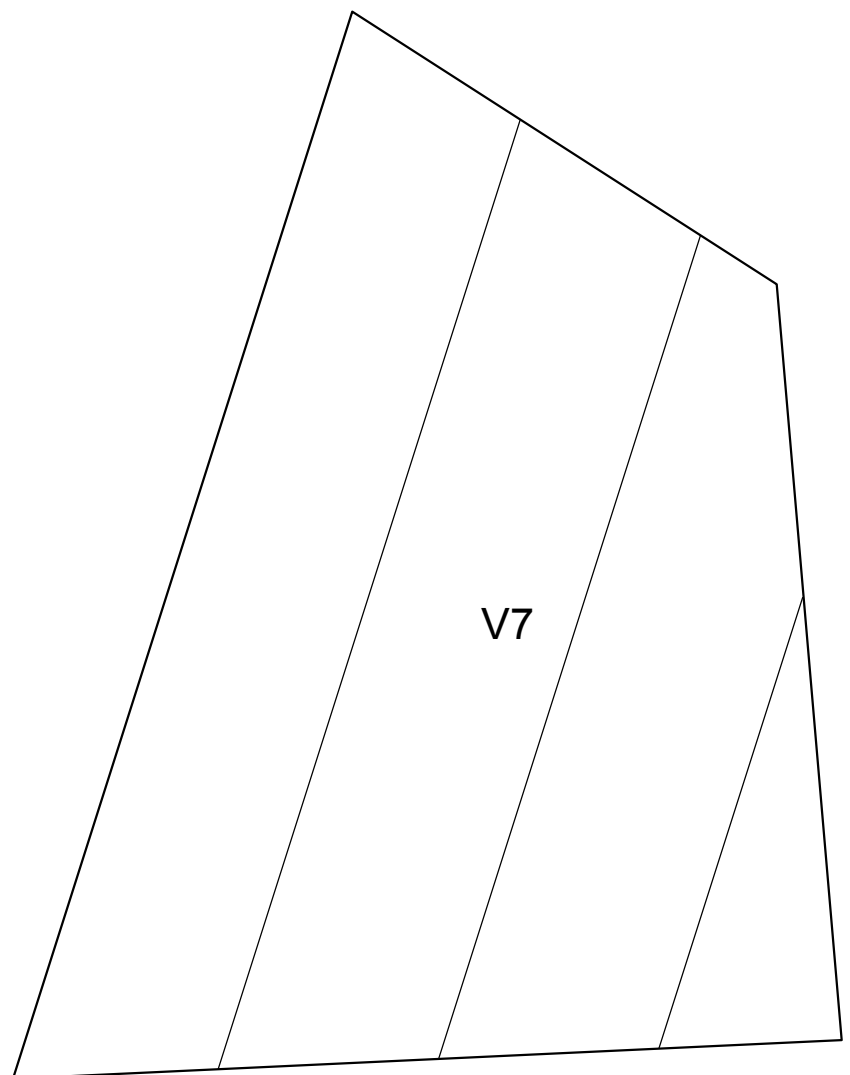
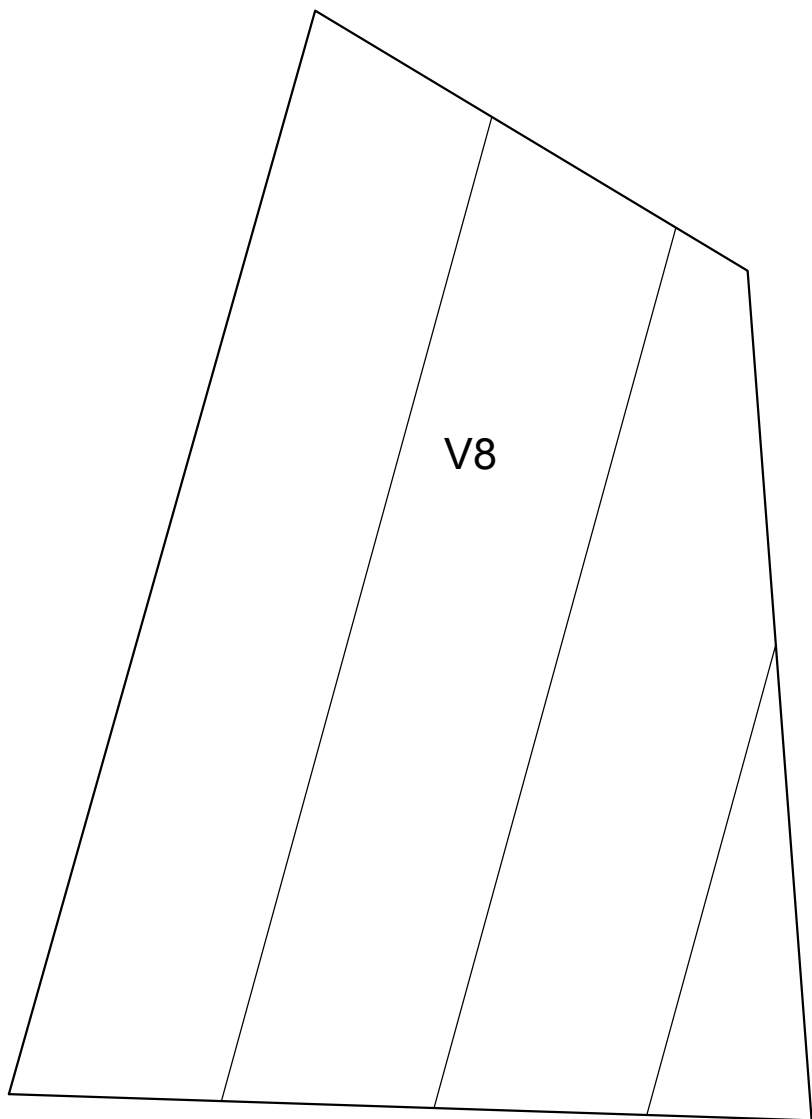
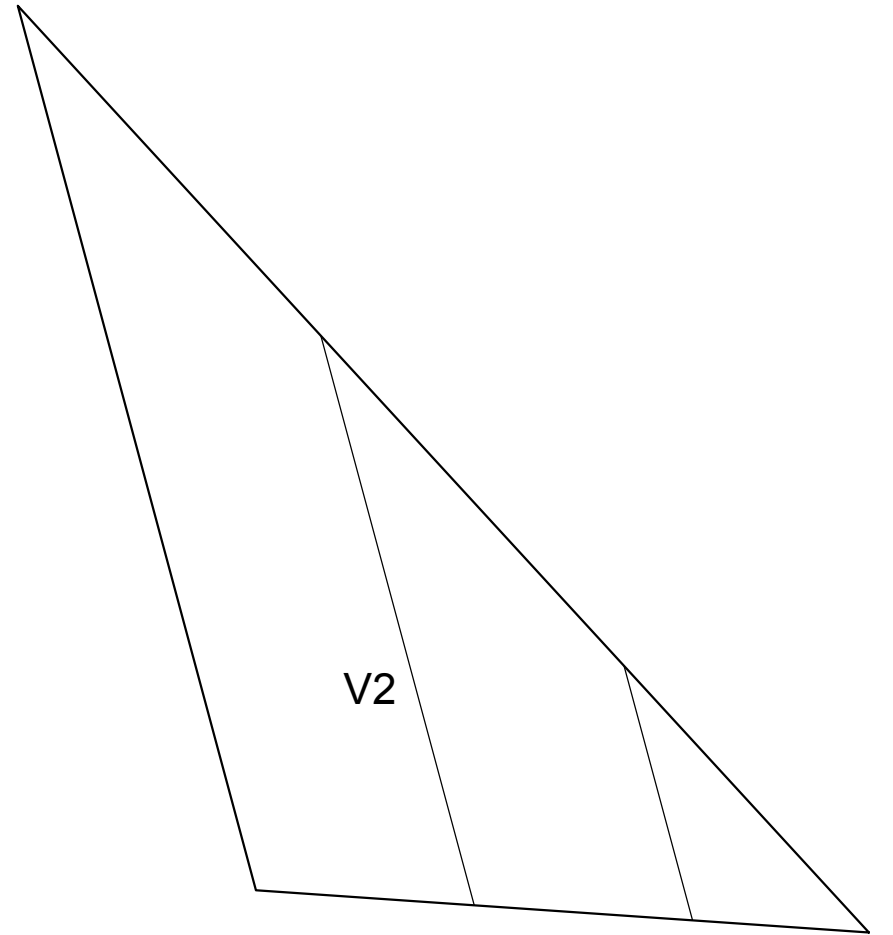
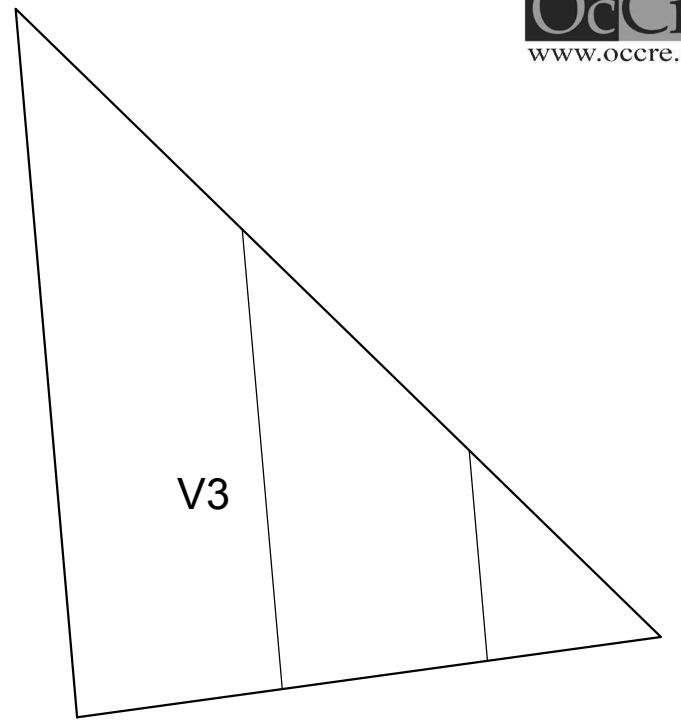
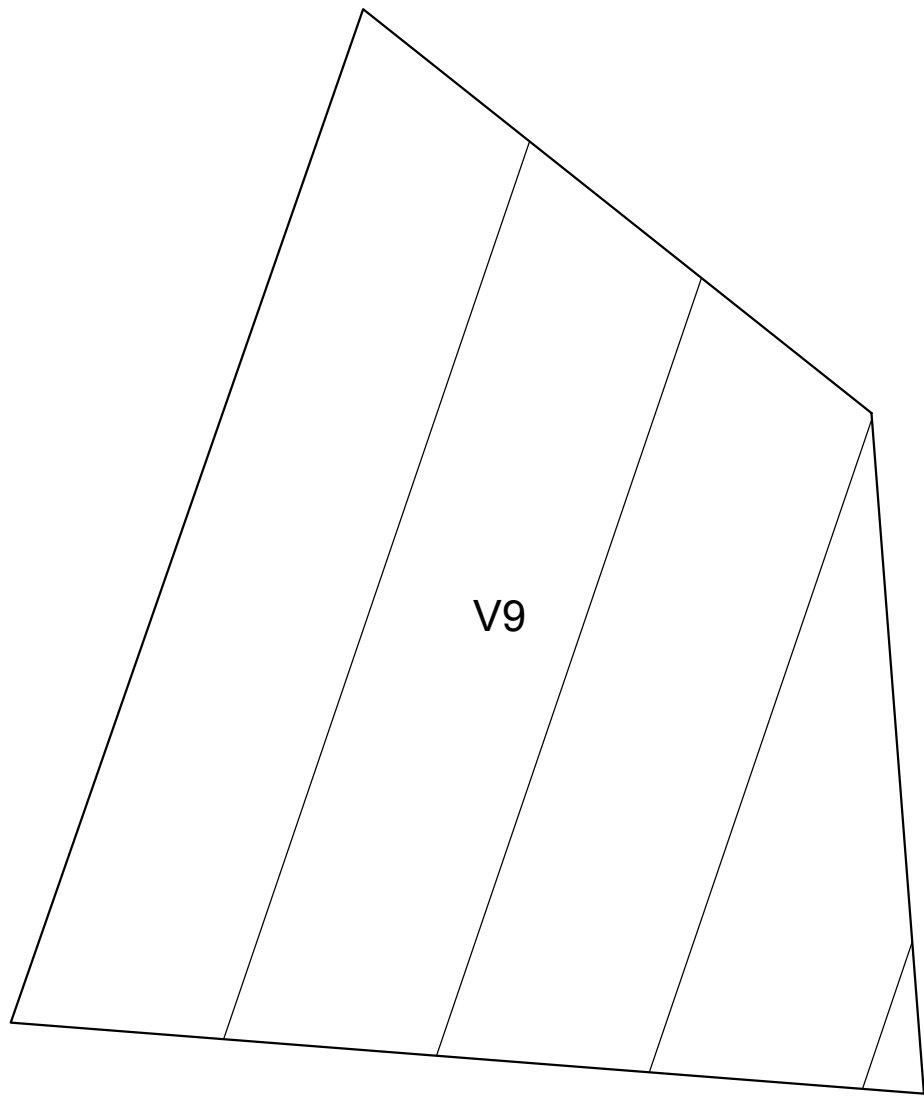

Endurance

A

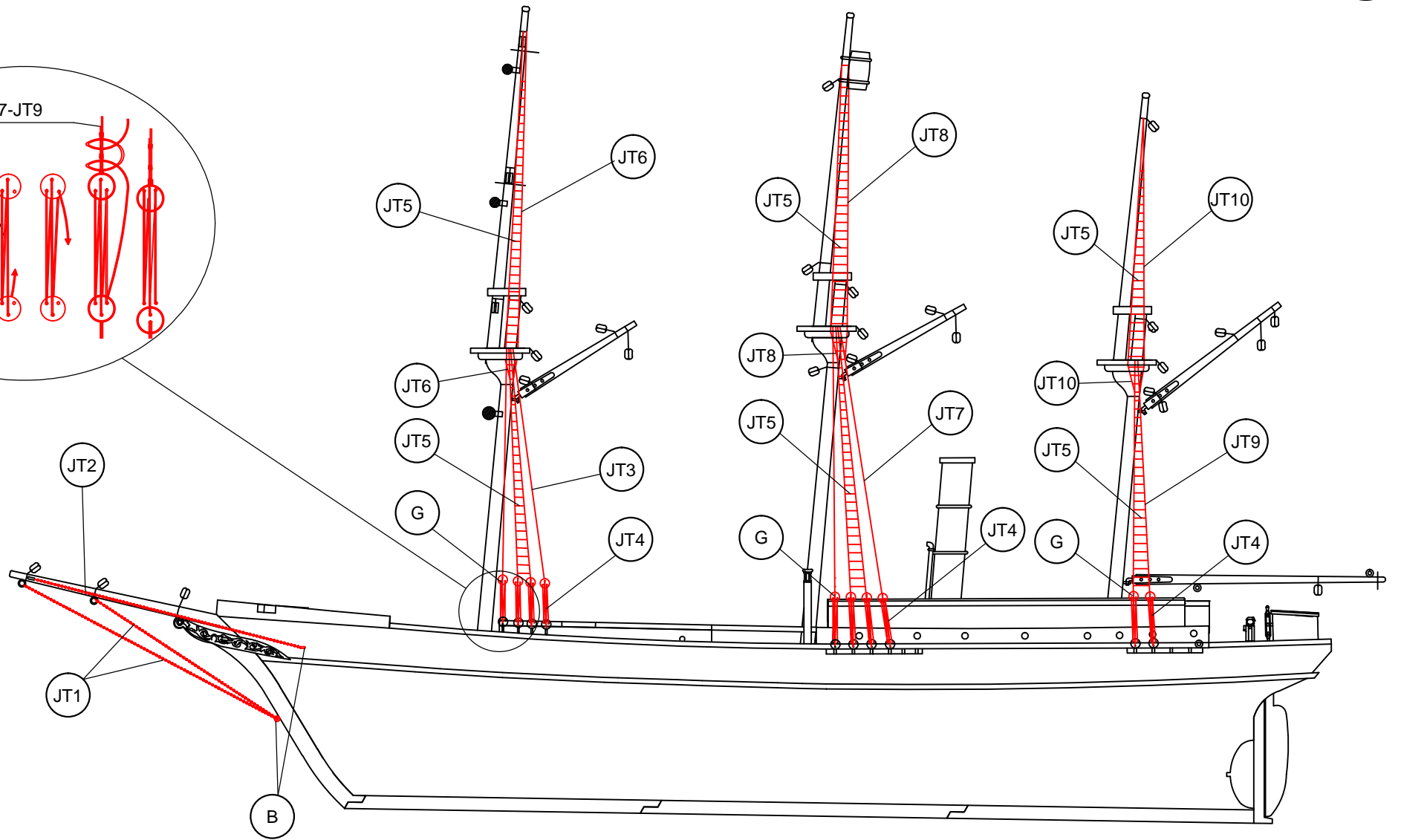
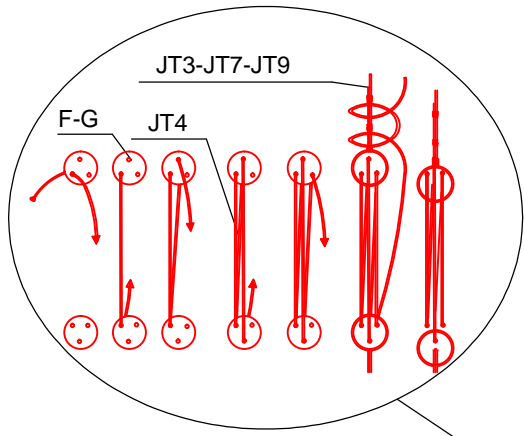

JT1	ø1x180	Latón / Brass / Laiton / Messing / Ottone	JT5	ø0,15x100	Hilo marrón / Brown thread / Fil brun / braunes Baumwollfaden / Filo marrone	JT9	ø0,50x450	Hilo marrón / Brown thread / Fil brun / braunes Baumwollfaden / Filo marrone
JT2	ø1x180	Latón / Brass / Laiton / Messing / Ottone	JT6	ø0,50x400	Hilo marrón / Brown thread / Fil brun / braunes Baumwollfaden / Filo marrone	JT10	ø0,50x400	Hilo marrón / Brown thread / Fil brun / braunes Baumwollfaden / Filo marrone
JT3	ø0,50x450	Hilo marrón / Brown thread / Fil brun / braunes Baumwollfaden / Filo marrone	JT7	ø0,50x500	Hilo marrón / Brown thread / Fil brun / braunes Baumwollfaden / Filo marrone	B	15	Latón / Brass / Latón / Messing / Ottone
JT4	ø0,15x200	Hilo crudo / Raw thread / Fil brut / Rohes Baumwollfaden / Filo crudo	JT8	ø0,50x400	Hilo marrón / Brown thread / Fil brun / braunes Baumwollfaden / Filo marrone	G	ø5	Composite / Composite / Composite / Composite / Composite

OcCre
www.occre.com

B

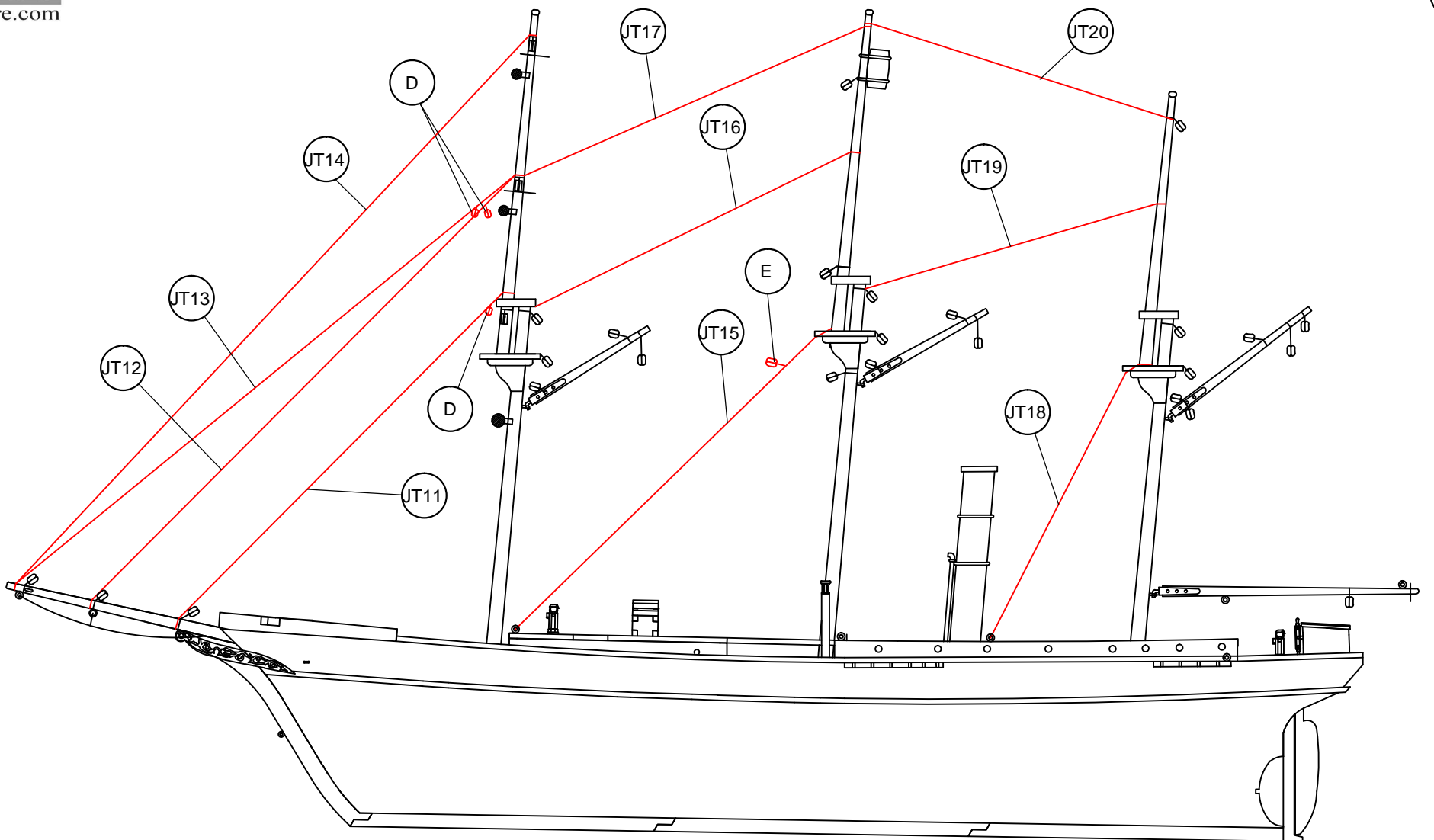

JT11	ø0,50x400	Hilo marrón / Brown thread / Fil brun / braunes Baumwollfaden / Filo marrone	JT15	ø0,50x475	Hilo marrón / Brown thread / Fil brun / braunes Baumwollfaden / Filo marrone	JT19	ø0,50x320	Hilo marrón / Brown thread / Fil brun / braunes Baumwollfaden / Filo marrone
JT12	ø0,50x475	Hilo marrón / Brown thread / Fil brun / braunes Baumwollfaden / Filo marrone	JT16	ø0,50x350	Hilo marrón / Brown thread / Fil brun / braunes Baumwollfaden / Filo marrone	JT20	ø0,50x340	Hilo marrón / Brown thread / Fil brun / braunes Baumwollfaden / Filo marrone
JT13	ø0,50x600	Hilo marrón / Brown thread / Fil brun / braunes Baumwollfaden / Filo marrone	JT17	ø0,50x350	Hilo marrón / Brown thread / Fil brun / braunes Baumwollfaden / Filo marrone	D	4	Composite / Composite / Composite / Composite / Composite
JT14	ø0,50x700	Hilo marrón / Brown thread / Fil brun / braunes Baumwollfaden / Filo marrone	JT18	ø0,50x325	Hilo marrón / Brown thread / Fil brun / braunes Baumwollfaden / Filo marrone	E	4	Composite / Composite / Composite / Composite / Composite

Endurance

C

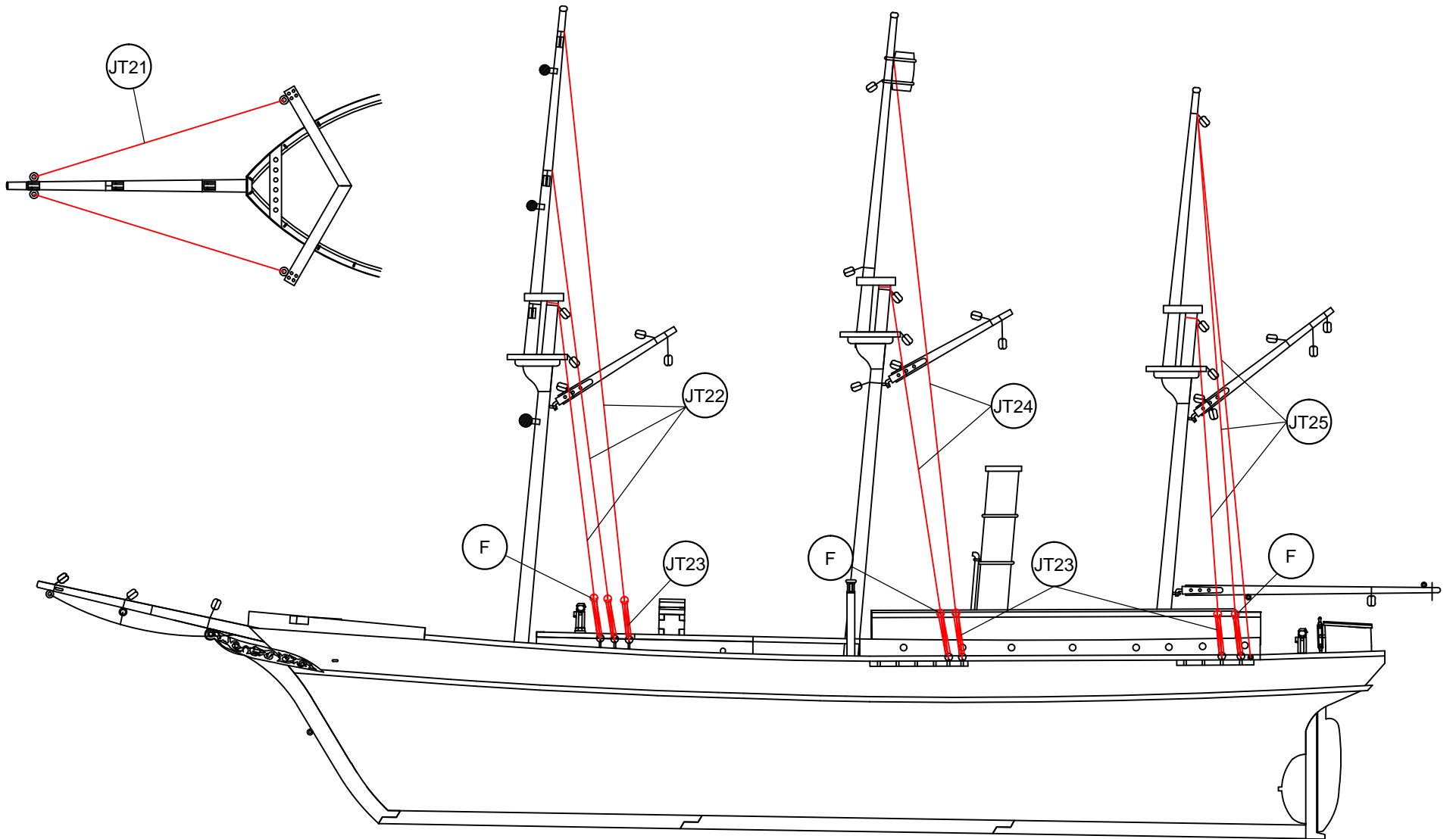

JT21	∅0,50x250	Hilo marrón / Brown thread / Fil brun / braunes Baumwollfaden / Filo marrone	JT24	∅0,50x900	Hilo marrón / Brown thread / Fil brun / braunes Baumwollfaden / Filo marrone
JT22	∅0,50x900	Hilo marrón / Brown thread / Fil brun / braunes Baumwollfaden / Filo marrone	JT25	∅0,50x800	Hilo marrón / Brown thread / Fil brun / braunes Baumwollfaden / Filo marrone
JT23	∅0,15x200	Hilo crudo / Raw thread / Fil brut / Rohes Baumwollfaden / Filo crudo	F	∅4	Composite / Composite / Composite / Composite / Composite

OcCre
www.occre.com

D

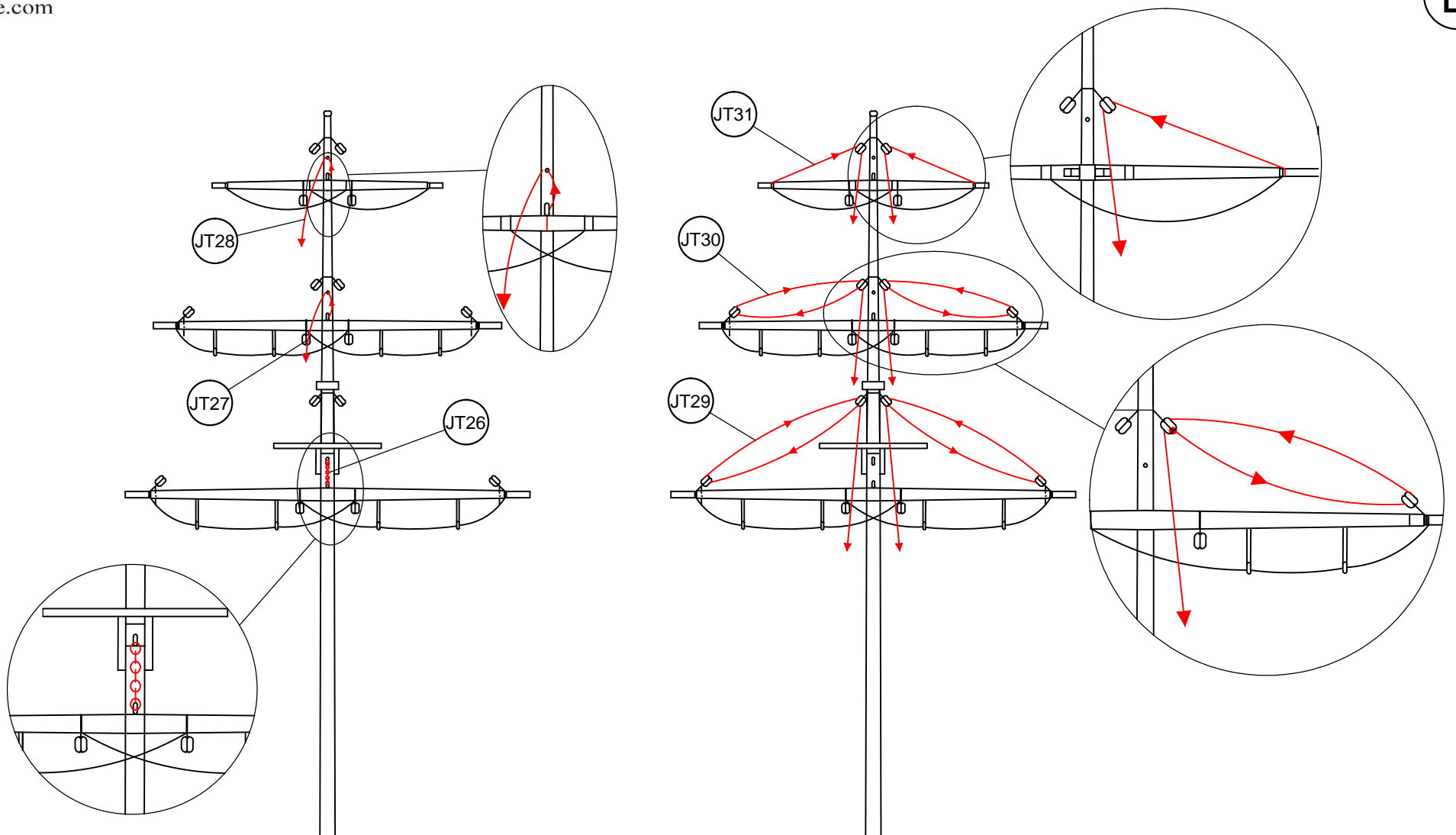

JT26	1x30	Latón / Brass / Laiton / Messing / Ottone	JT29	∅0,15x525	Hilo crudo / Raw thread / Fil brut / Rohes Baumwollfaden / Filo crudo
JT27	∅0,15x320	Hilo crudo / Raw thread / Fil brut / Rohes Baumwollfaden / Filo crudo	JT30	∅0,15x500	Hilo crudo / Raw thread / Fil brut / Rohes Baumwollfaden / Filo crudo
JT28	∅0,15x425	Hilo crudo / Raw thread / Fil brut / Rohes Baumwollfaden / Filo crudo	JT31	∅0,15x550	Hilo crudo / Raw thread / Fil brut / Rohes Baumwollfaden / Filo crudo

Endurance

E

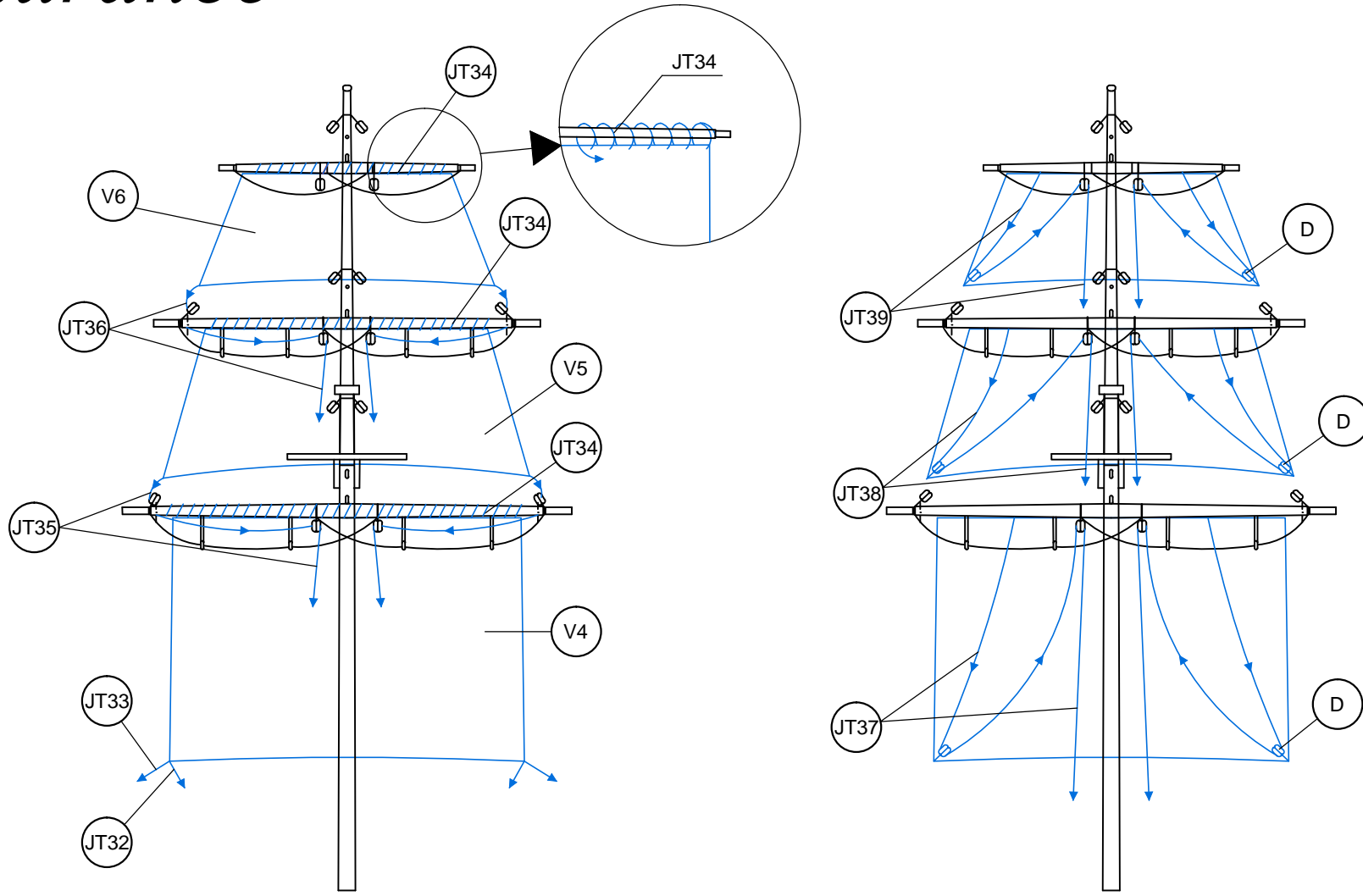

V4	Preformado / Preformed/ Préformé / Vorgeformt / Preformato	Tela / Cloth / Étoffe / Stoff / Tela	JT35	∅0,15x650	Hilo crudo / Raw thread / Fil brut / Rohes Baumwollfaden / Filo crudo
JT32	∅0,15x375	Hilo crudo / Raw thread / Fil brut / Rohes Baumwollfaden / Filo crudo	JT36	∅0,15x750	Hilo crudo / Raw thread / Fil brut / Rohes Baumwollfaden / Filo crudo
JT33	∅0,15x385	Hilo crudo / Raw thread / Fil brut / Rohes Baumwollfaden / Filo crudo	JT37	∅0,15x800	Hilo crudo / Raw thread / Fil brut / Rohes Baumwollfaden / Filo crudo
V5	Preformado / Preformed/ Préformé / Vorgeformt / Preformato	Tela / Cloth / Étoffe / Stoff / Tela	JT38	∅0,15x975	Hilo crudo / Raw thread / Fil brut / Rohes Baumwollfaden / Filo crudo
JT34	∅0,15x1000	Hilo crudo / Raw thread / Fil brut / Rohes Baumwollfaden / Filo crudo	JT39	∅0,15x1100	Hilo crudo / Raw thread / Fil brut / Rohes Baumwollfaden / Filo crudo
V6	Preformado / Preformed/ Préformé / Vorgeformt / Preformato	Tela / Cloth / Étoffe / Stoff / Tela	D	4	Composite / Composite / Composite / Composite / Composite

OcCre
www.occre.com

Aparejo de velas / Sail rig / Gréement
Segel takelage / Sartiamé da vela

F

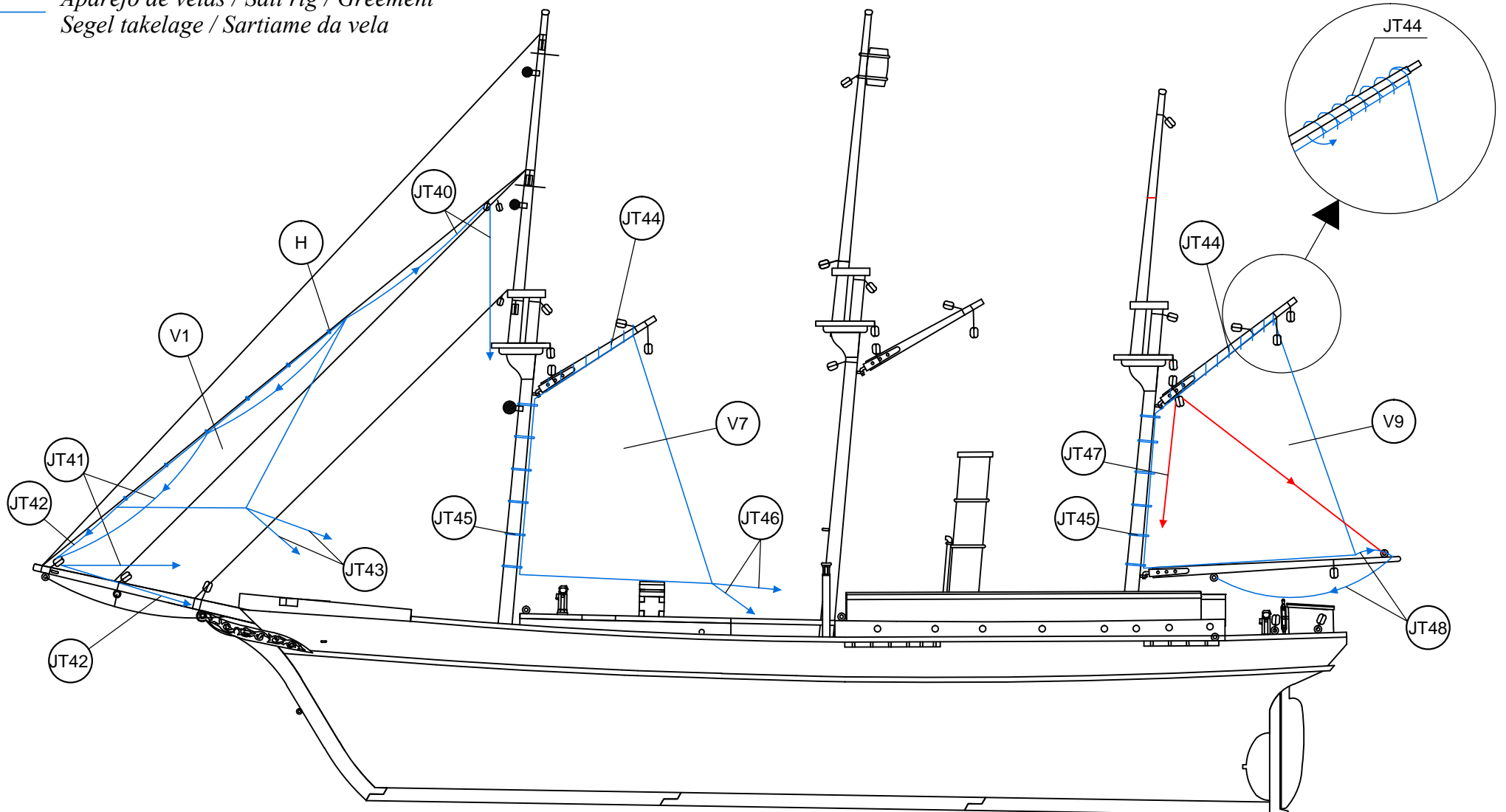

V1	Preformado / Preformed/ Préformé / Vorgeformt / Preformato	Tela / Cloth / Étoffe / Stoff / Tela	V7	Preformado / Preformed/ Préformé / Vorgeformt / Preformato	Tela / Cloth / Étoffe / Stoff / Tela	V9	Preformado / Preformed/ Préformé / Vorgeformt / Preformato	Tela / Cloth / Étoffe / Stoff / Tela
JT40	∅0,15x450	Hilo crudo / Raw thread / Fil brut / Rohes Baumwollfaden / Filo crudo	JT44	∅0,15x1000	Hilo crudo / Raw thread / Fil brut / Rohes Baumwollfaden / Filo crudo	JT47	∅0,15x650	Hilo crudo / Raw thread / Fil brut / Rohes Baumwollfaden / Filo crudo
JT41	∅0,15x550	Hilo crudo / Raw thread / Fil brut / Rohes Baumwollfaden / Filo crudo	JT45	∅10	Latón / Brass / Laiton / Messing Ottone	JT48	∅0,15x390	Hilo crudo / Raw thread / Fil brut / Rohes Baumwollfaden / Filo crudo
JT42	∅0,15x300	Hilo crudo / Raw thread / Fil brut / Rohes Baumwollfaden / Filo crudo	JT46	∅0,15x400	Hilo crudo / Raw thread / Fil brut / Rohes Baumwollfaden / Filo crudo	H	∅3	Latón / Brass / Laiton / Messing Ottone
JT43	∅0,15x350	Hilo crudo / Raw thread / Fil brut / Rohes Baumwollfaden / Filo crudo						

Endurance

Aparejo de velas / Sail rig / Gréement
Segel takelage / Sartiamé da vela

G

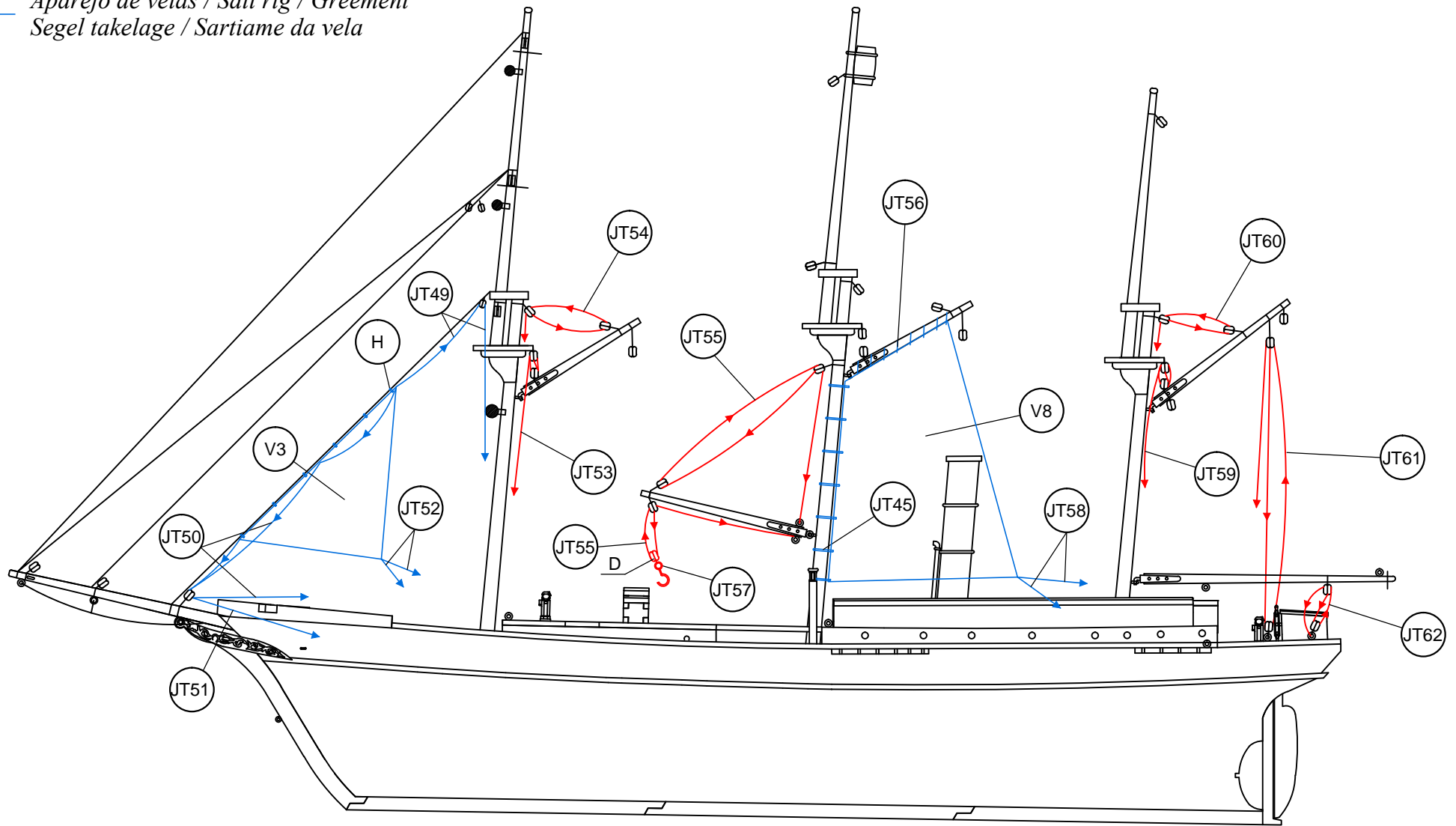

V3	Preformado / Preformed / Préformé / Vorgeformt / Prefornato	Tela / Cloth / Étouffe / Stoff / Tela	JT54	∅0,15x500	Hilo crudo / Raw thread / Fil brut / Rohes Baumwollfaden / Filo crudo	JT59	∅0,15x350	Hilo crudo / Raw thread / Fil brut / Rohes Baumwollfaden / Filo crudo
JT49	∅0,15x485	Hilo crudo / Raw thread / Fil brut / Rohes Baumwollfaden / Filo crudo	JT55	∅0,15x500	Hilo crudo / Raw thread / Fil brut / Rohes Baumwollfaden / Filo crudo	JT60	∅0,15x475	Hilo crudo / Raw thread / Fil brut / Rohes Baumwollfaden / Filo crudo
JT50	∅0,15x425	Hilo crudo / Raw thread / Fil brut / Rohes Baumwollfaden / Filo crudo	V8	Preformado / Preformed / Préformé / Vorgeformt / Prefornato	Tela / Cloth / Étouffe / Stoff / Tela	JT61	∅0,15x600	Hilo crudo / Raw thread / Fil brut / Rohes Baumwollfaden / Filo crudo
JT51	∅0,15x325	Hilo crudo / Raw thread / Fil brut / Rohes Baumwollfaden / Filo crudo	JT56	∅0,15x1000	Hilo crudo / Raw thread / Fil brut / Rohes Baumwollfaden / Filo crudo	JT62	∅0,15x400	Hilo crudo / Raw thread / Fil brut / Rohes Baumwollfaden / Filo crudo
JT52	∅0,15x300	Hilo crudo / Raw thread / Fil brut / Rohes Baumwollfaden / Filo crudo	JT57	15	Latón / Brass / Laiton / Messing Ottone	D	4	Composite / Composite / Composite / Composite / Composite
JT53	∅0,15x350	Hilo crudo / Raw thread / Fil brut / Rohes Baumwollfaden / Filo crudo	JT58	∅0,15x375	Hilo crudo / Raw thread / Fil brut / Rohes Baumwollfaden / Filo crudo	H	∅3	Latón / Brass / Laiton / Messing Ottone

OcCre
www.occre.com

H

Aparejo de velas / Sail rig / Gréement
Segel takelage / Sartiamé da vela

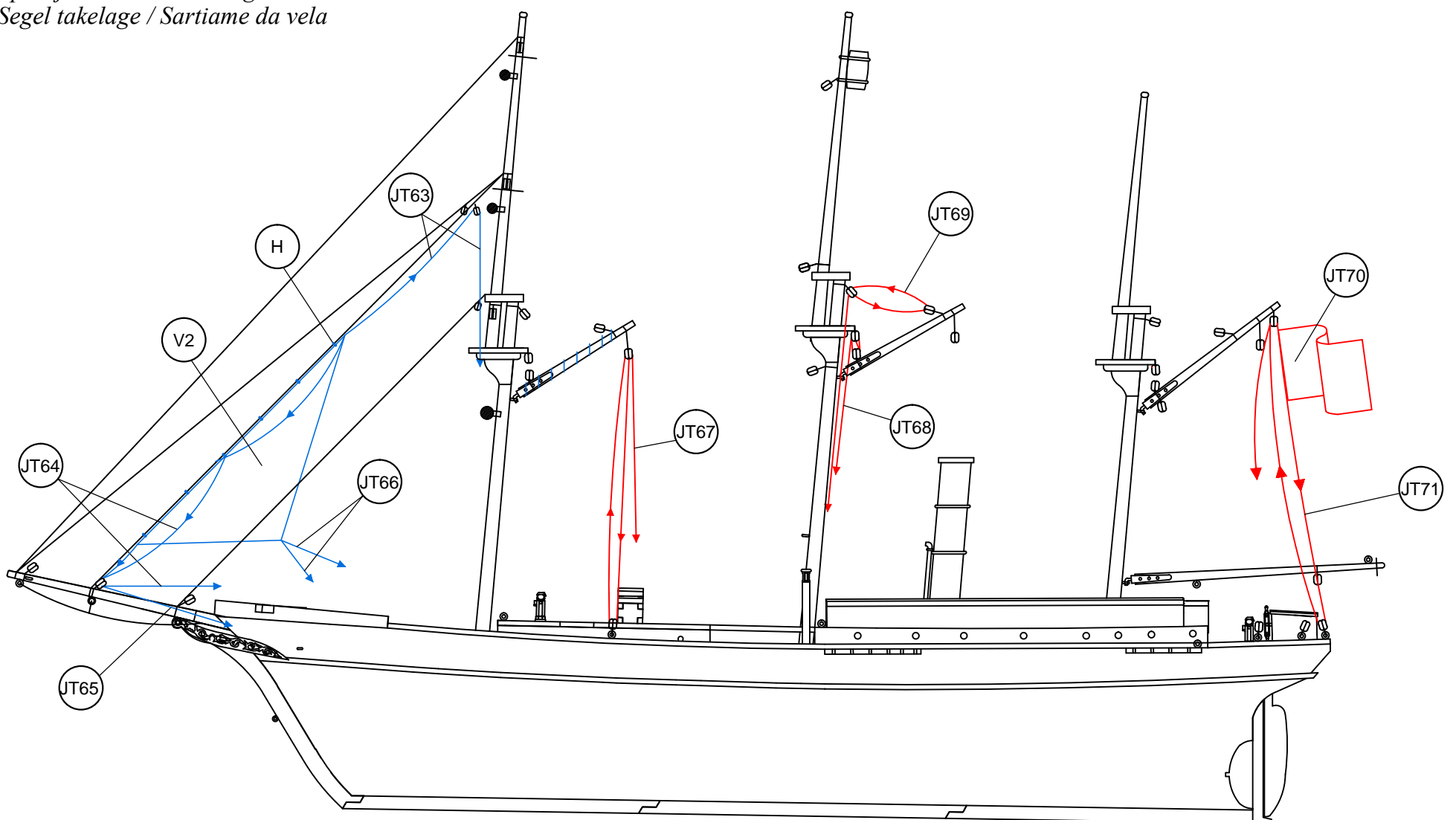

V2	Preformado / Preformed / Préformé / Vorgeformt / Prefornato	Tela / Cloth / Étouffe / Stoff / Tela	JT66	∅0,15x300	Hilo crudo / Raw thread / Fil brut / Rohes Baumwollfaden / Filo crudo	JT70	Preformado / Preformed / Préformé / Vorgeformt / Prefornato	Tela / Cloth / Étouffe / Stoff / Tela
JT63	∅0,15x500	Hilo crudo / Raw thread / Fil brut / Rohes Baumwollfaden / Filo crudo	JT67	∅0,15x600	Hilo crudo / Raw thread / Fil brut / Rohes Baumwollfaden / Filo crudo	JT71	∅0,15x600	Hilo crudo / Raw thread / Fil brut / Rohes Baumwollfaden / Filo crudo
JT64	∅0,15x400	Hilo crudo / Raw thread / Fil brut / Rohes Baumwollfaden / Filo crudo	JT68	∅0,15x380	Hilo crudo / Raw thread / Fil brut / Rohes Baumwollfaden / Filo crudo	H	∅3	Latón / Brass / Laiton / Messing Ottone
JT65	∅0,15x350	Hilo crudo / Raw thread / Fil brut / Rohes Baumwollfaden / Filo crudo	JT69	∅0,15x490	Hilo crudo / Raw thread / Fil brut / Rohes Baumwollfaden / Filo crudo			

Endurance

Aparejo de velas / Sail rig / Gréement
Segel takelage / Sartiame da vela

I

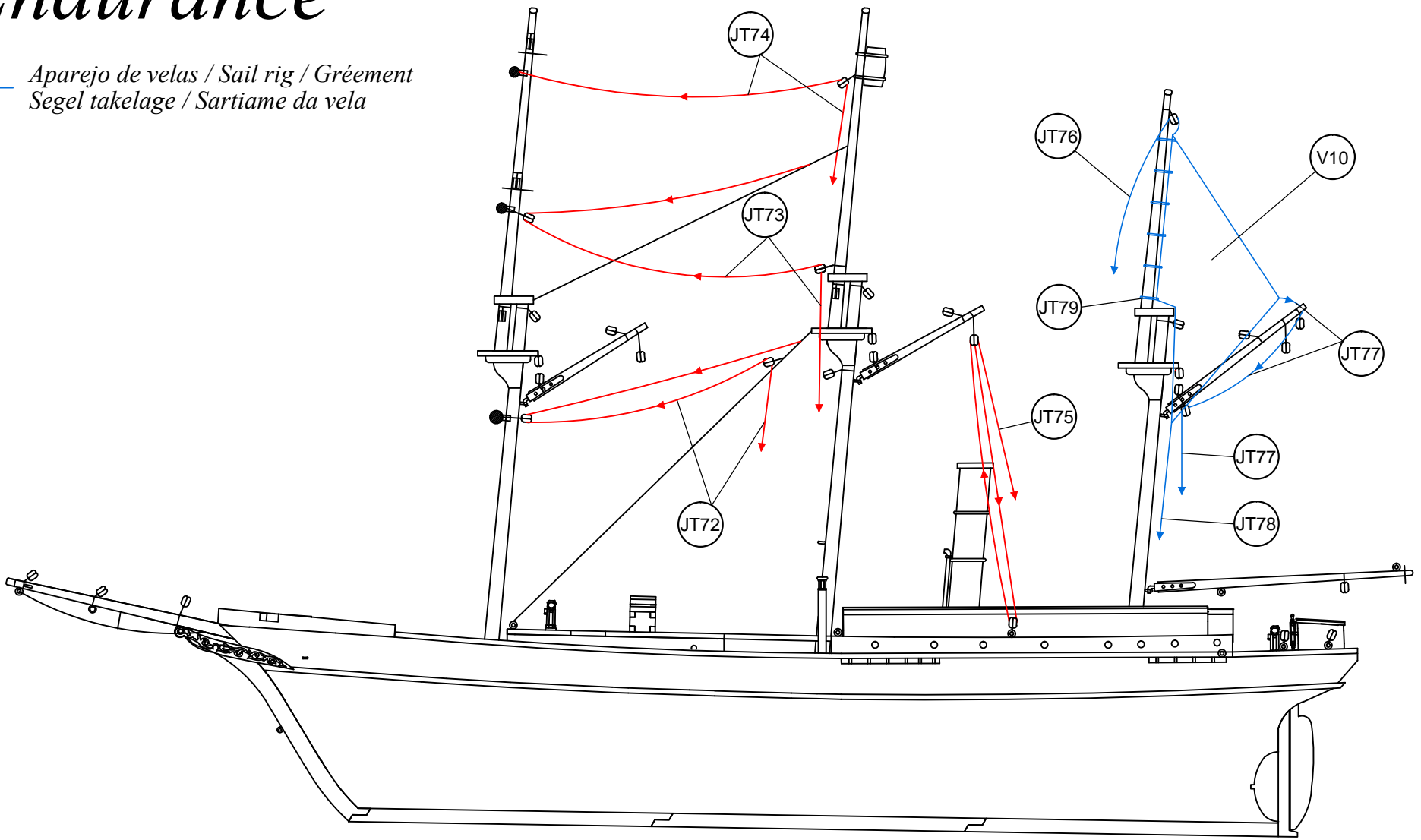

JT72	∅0,15x650	Hilo crudo / Raw thread / Fil brut / Rohes Baumwollfaden / Filo crudo	JT76	∅0,15x700	Hilo crudo / Raw thread / Fil brut / Rohes Baumwollfaden / Filo crudo
JT73	∅0,15x800	Hilo crudo / Raw thread / Fil brut / Rohes Baumwollfaden / Filo crudo	JT77	∅0,15x650	Hilo crudo / Raw thread / Fil brut / Rohes Baumwollfaden / Filo crudo
JT74	∅0,15x700	Hilo crudo / Raw thread / Fil brut / Rohes Baumwollfaden / Filo crudo	JT78	∅0,15x425	Hilo crudo / Raw thread / Fil brut / Rohes Baumwollfaden / Filo crudo
JT75	∅0,15x675	Hilo crudo / Raw thread / Fil brut / Rohes Baumwollfaden / Filo crudo	JT79	8	Latón / Brass / Laiton / Messing Ottone
V10	Preformado / Preformed/ Préformé / Vorgeformt	Tela / Cloth / Étouffe / Stoff / Tela			

OcCre
www.occre.com

J

